

# Phase 1: A Journey to Mir 1994~1998

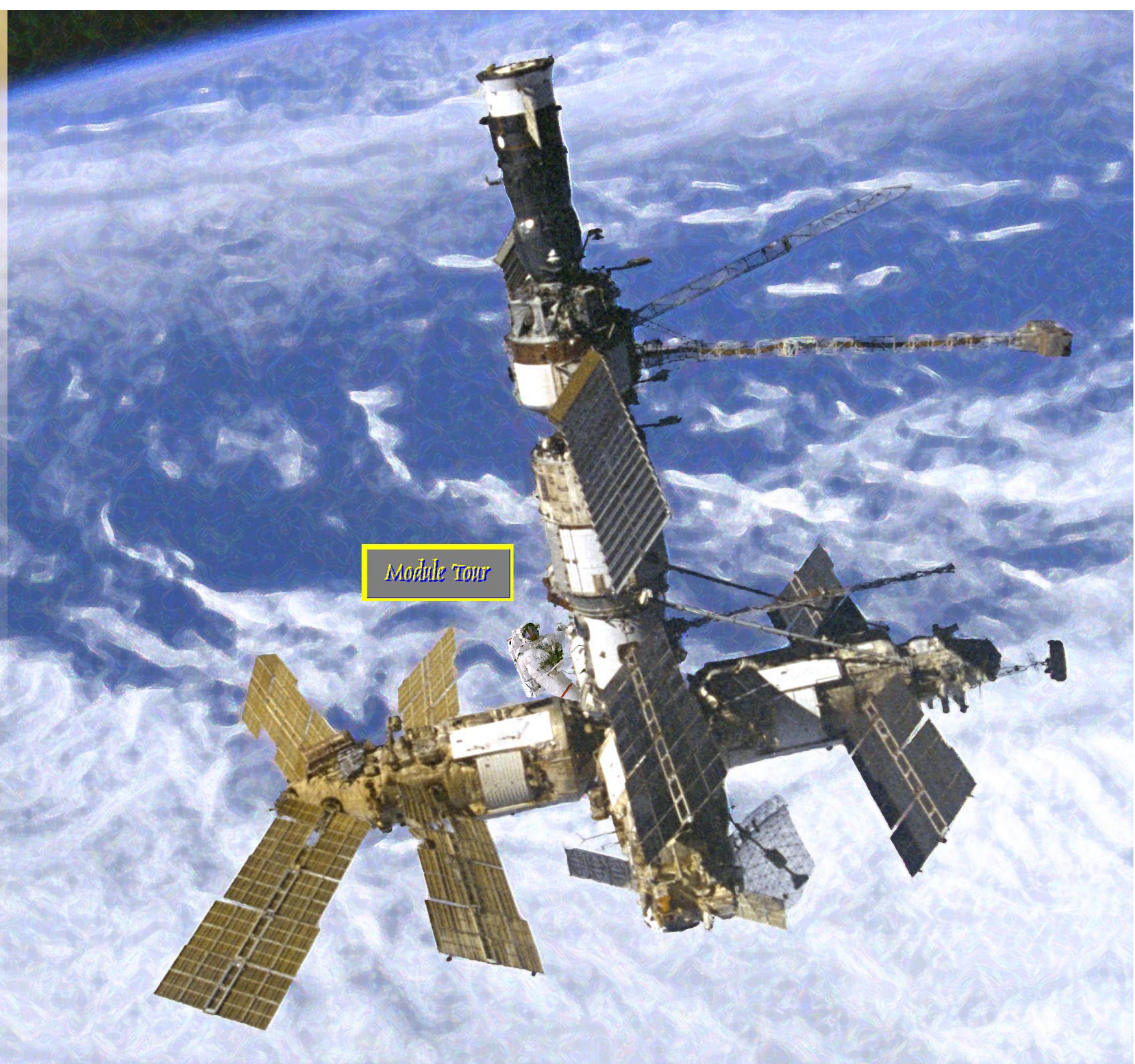

*Module Tour*

*List of Experiments*

*List of Experiments by Increment*

# ANGULAR LIQUID BRIDGE EXPERIMENT - MGBX

## EXPERIMENT DESCRIPTION

The purpose of the Angular Liquid Bridge (ALB) experiment is to study equilibrium fluid interface behavior under microgravity conditions. Configurations to be studied are those in which liquid covers the base of the container or rises up the wedge vertex (ALB-Movable Wedge Vessel) and those in which liquid forms a bridge between the two faces of the wedge (ALB Vessel).

In the performance of the ALB investigation, a container with a pie-shaped cross section (ALB-Movable Wedge Vessel) and a container with removable parallel plates (ALB Vessel) are proposed for study. The containers are designed to exploit the reduced gravity environment to observe particularly sensitive capillary phenomena. The containers are intended as a test of the physical validity of the concept of contact angle as envisioned by the classical Young-Gauss theory.

Two different experiment vessels are to be used and both use immersion fluid (hydrogenated terphenyl) as the test fluid. ALB vessel also uses distilled water. One at a time, these vessels are placed in the MGBx. A crewmember opens the ALB-Movable Wedge Vessel valve on the side of the container housing and manually fills the vessel from the built-in reservoir using a hand cranked piston. After stabilizing, the wedge angle is adjusted by a hand cranked knob. A crewmember opens the ALB vessel and removes the parallel plates, coats the surfaces, and injects the test fluid onto the solid plate surface. The plate is then carefully placed back in the ALB vessel. The solid surfaces are brought together by turning a hand cranked knob until a liquid bridge is formed between them. The wedge angle of these solid

surfaces are then adjusted by another hand cranked knob. Solid surfaces can be replaced to perform more test points.

## SCIENCE OBJECTIVES

- Observe under microgravity conditions the behavior of a liquid in a wedge container (ALB-Movable Wedge Vessel).
- Observe under microgravity conditions the stability of a liquid bridge between two parallel plates with contact angle conditions.
- Observe under microgravity conditions the behavior of the liquid bridge between two faces of a wedge as the wedge angle is increased through its predicted critical value.

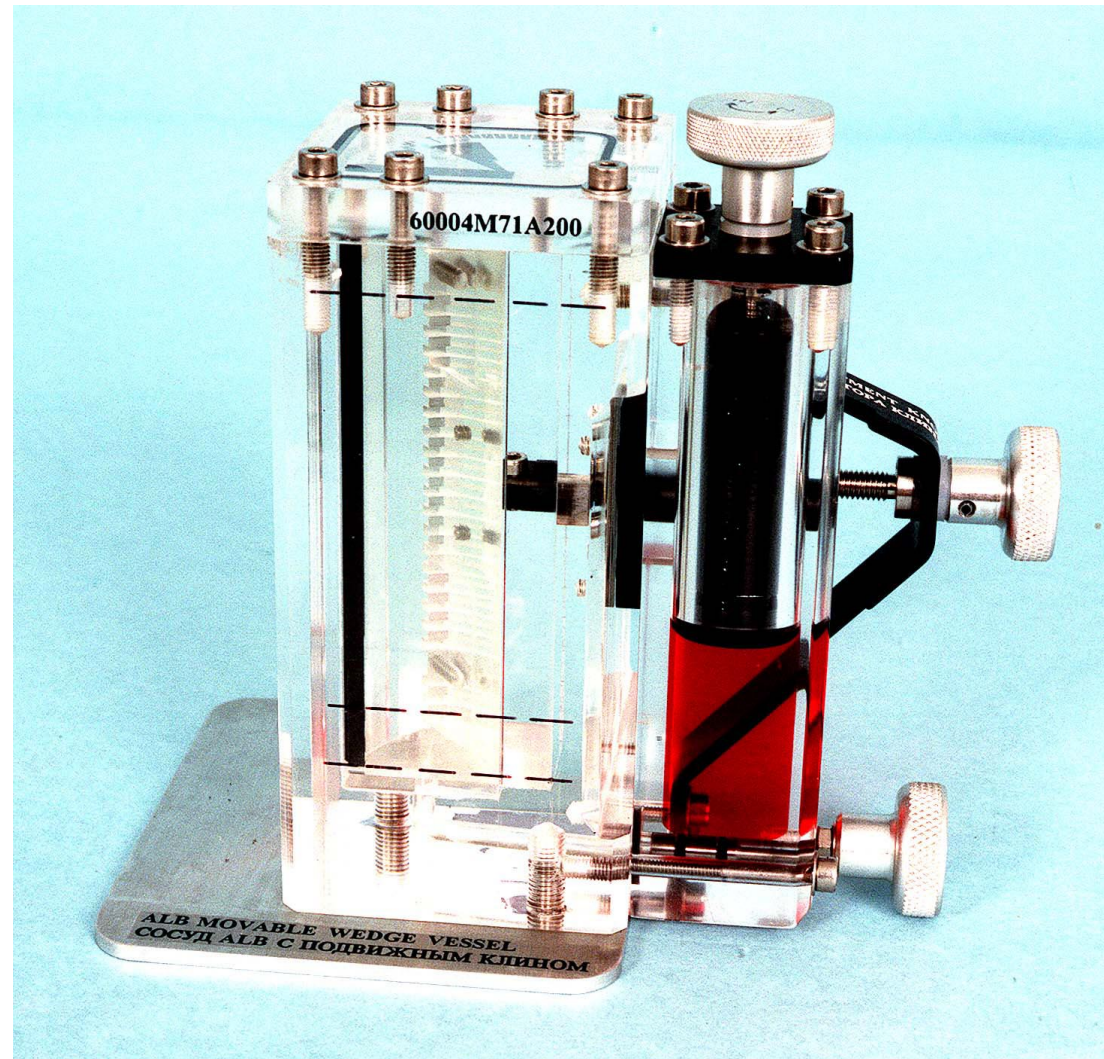

Figure MG-1 Movable Wedge Vessel - Front View

96-13140



Figure MG-2 Movable Wedge Vessel - Side View

96-13141

**Principal Investigator:**  
P. Concus

### ALB MOVABLE WEDGE VESSEL

P/N: 60004M71A200  
Mass: 1.00 kg  
Power: N/A  
x, y, z: 15.70 x 14.60 x 7.60 cm

### ALB VESSEL

P/N: 60032MAFH000  
Mass: 1.60 kg  
Power: N/A  
x, y, z: 17.50 x 15.20 x 11.10 cm

### ALB PARTS BOX

P/N: 60033MAFH100  
Mass: 4.50 kg  
Power: N/A  
x, y, z: 30.50 x 12.70 x 22.90 cm

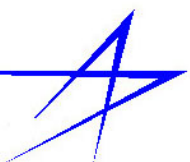

## FUNCTIONAL OBJECTIVES

- Load the ALB apparatus into the MGBx, and activate the MGBx.
- Deploy liquid bridges and/or drops. (Fill test cell for ALB movable wedge vessel only.)
- Vary wedge angle in prescribed increments.
- Observe and record the behavior of the liquids with video.
- Unload the ALB apparatus and deactivate the MGBx.

## HARDWARE DESCRIPTIONS

### ALB-MOVABLE WEDGE VESSEL

The ALB-Movable Wedge Vessel is a self-contained unit in a pie-shaped cross section container and a reservoir (filled with fluid on the ground) on one end used to fill the experiment container section on orbit. An aluminum piston and a stainless steel drive screw are used to manually transfer the experiment fluid from the reservoir into the geometric experiment area of the container after opening a transfer valve.

### ALB VESSEL

The ALB Vessel is a rectangular cross section container. A crewmember opens the ALB vessel and remove the parallel plates, coats the surfaces, and manually deploys a liquid drop/bridge between two parallel plates with a prefilled syringe. The plates have both linear and angular translation motion. Gears will be driven by a hand cranked knob to provide the required plate motions.

## HARDWARE INTERFACE WITH SYSTEMS

The ALB experiment containers are designed for experiment containment and used in the MGBx working area. The ALB containers interface with the MGBx hold-down plate using the quick connect clamps (2) and clamping the hardware to the MGBx hold-down plate. \*

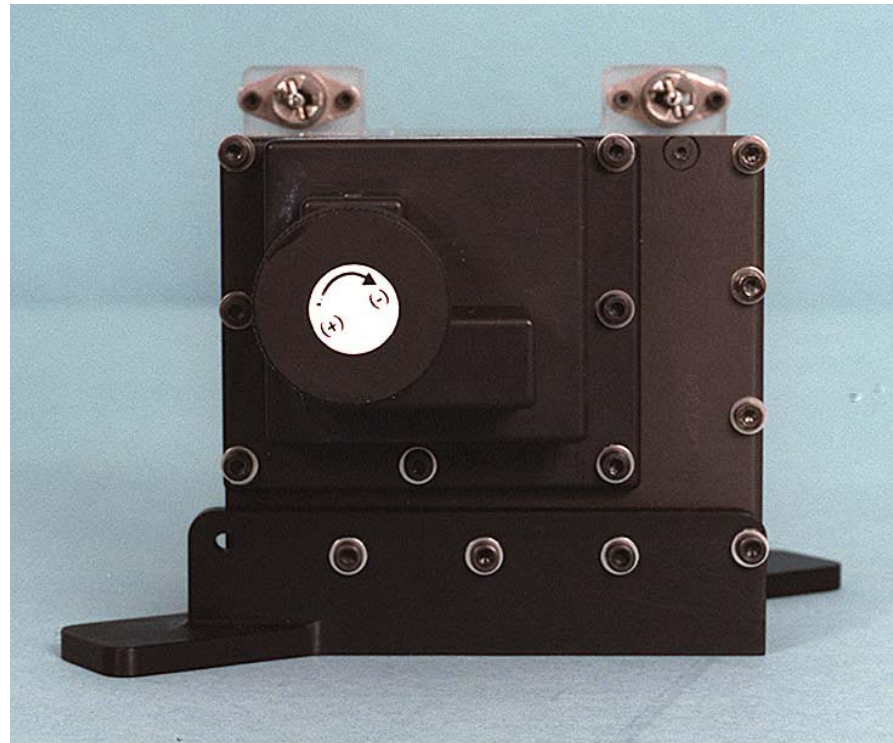

96-13213

Figure MG-3 ALB Vessel Side View Showing the Control Dial



96-13146

Figure MG-5 ALB Parts Box



96-13212

Figure MG-4 ALB Vessel Front View



# BINARY COLLOIDAL ALLOY TEST (BCAT-2)

## EXPERIMENT DESCRIPTION

Extended flight on the Mir offers an intriguing possibility of studying the long-time behavior of binary colloidal alloys in a microgravity environment void of the affects of sedimentation and buoyancy. The formation of binary colloidal crystal alloys is inherently slower than single particle crystals. In addition, some of the structures seem to take extended periods to crystallize. Thus, if this experiment were flown on Mir, with a six-month time schedule, additional tests could be conducted to explore regions of the phase space of binary colloidal crystal alloys that have never been explored to date.

## SCIENCE OBJECTIVES

1. To grow crystal structures using a number of colloidal samples covering a wide range of concentrations in the MGBX.
2. To take still photographs of the “slow growth” crystals over an extended period (3 months) and video record the “rapid growth” crystals periodically (several times per day) in order to document crystal formation.

## HARDWARE DESCRIPTIONS

The BCAT-2 is designed and built at NASA and will utilize the Microgravity Glovebox (MGBx).

## EXPERIMENT CONTAINER

The experiment container is used to house all BCAT-2 hardware. The experiment container is to be stowed in a Mir stowage locker at all times, except during transfer operations between the Space Shuttle and Mir.



Figure MG-6 BCAT-2 Flight Case S97-06681



Figure MG-8 BCAT-2 Packed for Flight

S97-06673

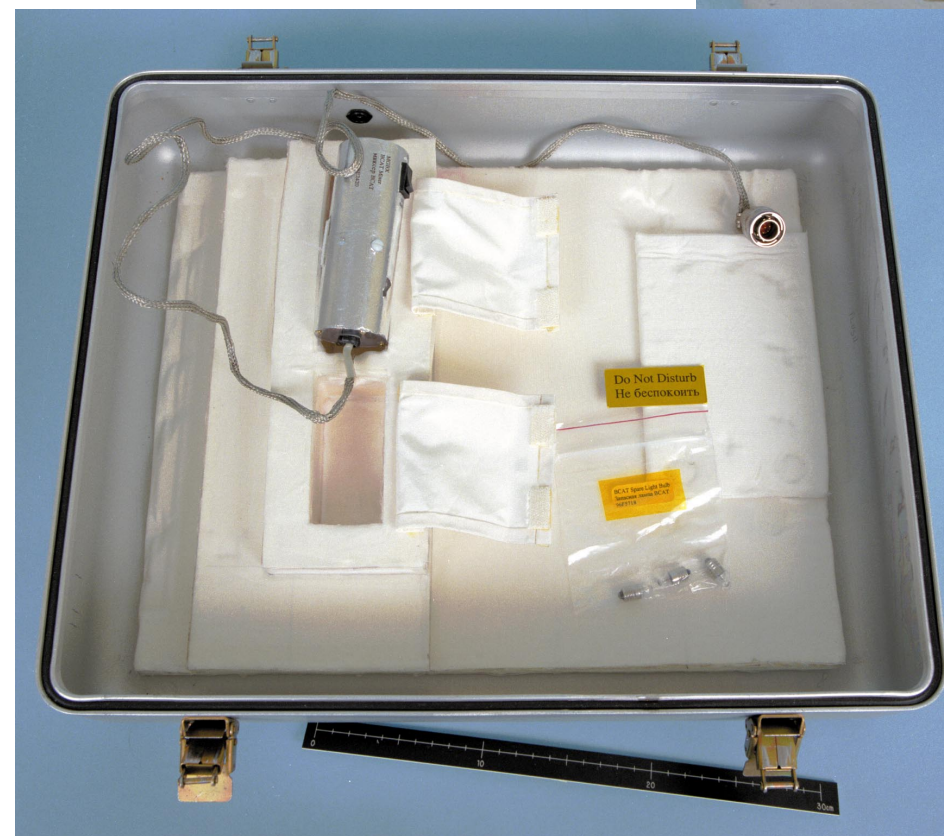

Figure MG-7 BCAT-2 Lid Stowage

S97-

**Principal Investigator:**  
 Dave Weitz  
 University of Pennsylvania  
 Professor of Physics  
 (215)898-7522

Peter Pusey, FRS  
 University of Edinburgh -  
 Scotland Dept. of Physics  
 44-31-650-5255

<b>BCAT-2</b>	
Power Consumption:	N/A
Start-up Current:	N/A
Onboard Elect. Supply:	MGBx power
Insulation Resistance:	N/A
Operational Life:	5 years
<b>BCAT EXPERIMENT CONTAINER</b>	
P/N:	67041F1001
Qty.:	1
Mass:	21.35 kg
Power:	0
x,y,z:	48.56 x 39.67 x 22.23 cm

## Rapid-Growth Sample Module

The rapid-growth sample module is stowed in foam inside the experiment container when not in use. The rapid-growth sample module consists of a flat Aluminum plate in which five recesses have been cut out to accept five rapid-growth sample cuvettes. Each cuvette has a cap with an O-ring seal, which serves as the first level of containment for the Class 1 fluids inside. In addition, a recess is provided for a glass focusing reticle. The aluminum plate, with cuvettes and reticle installed, is sandwiched between two plates of clear Lexan.

At each Aluminum/Lexan interface, two concentric O-rings that completely encircle the five cuvettes, are used to provide a total of three levels of containment. The rapid-growth sample module interfaces to the rapid-growth sample support structure mounts via four captive screws in the sample module.

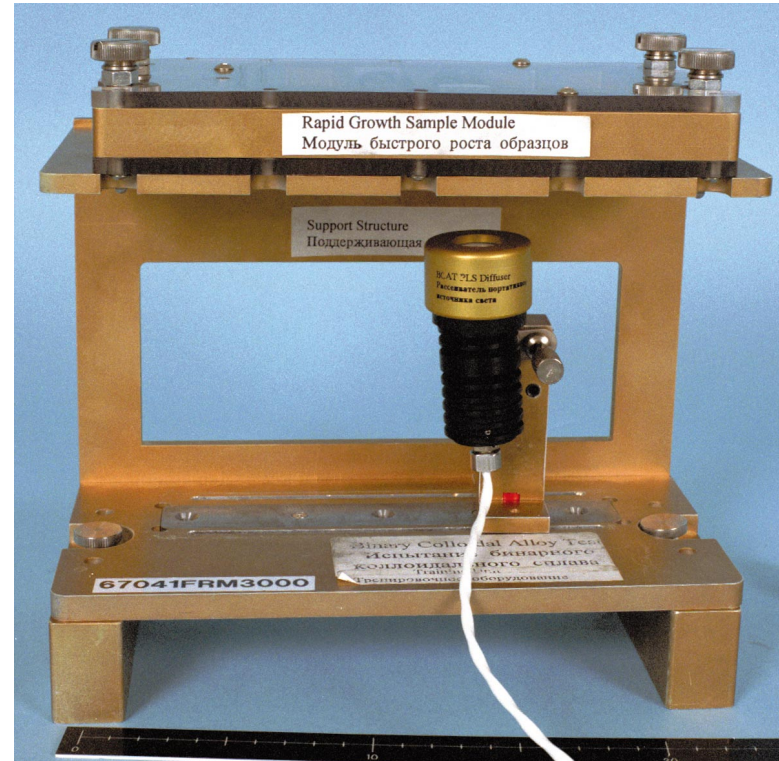

Figure MG-10 Rapid-Growth Sample Module Front (Training) S97-01270



Figure MG-11 Rapid-Growth Sample Module Right Side (Training) S97-01272

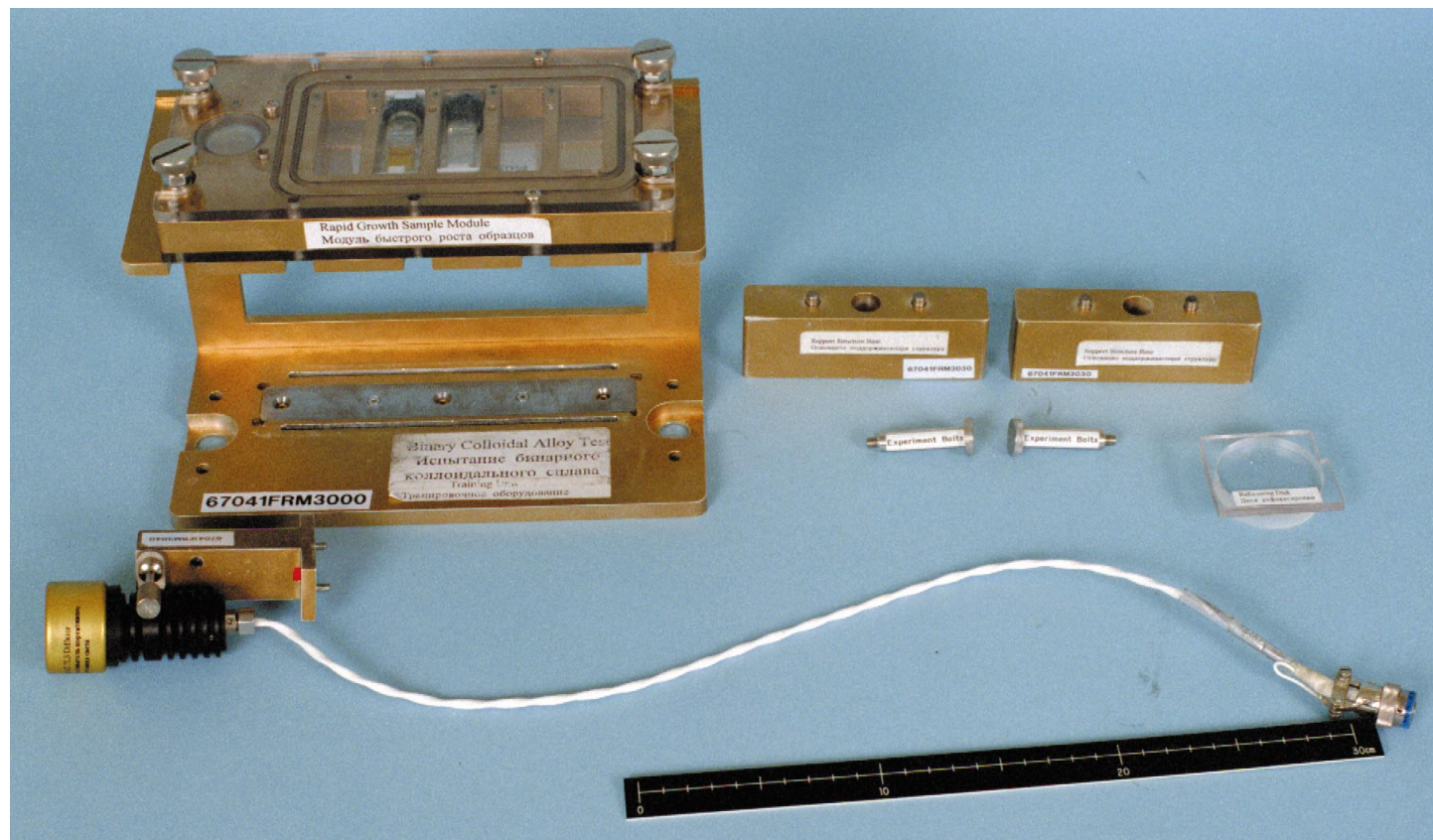

Figure MG-9 Rapid-Growth Sample Module Base Assembly (Training) S97-01273



Figure MG-12 Rapid-Growth Sample Module and Related Hardware (Training) S97-01276



Figure MG-13 Rapid-Growth Sample Module Diffuser Tracks (Training) S97-01277

## Rapid-Growth Sample Support Structure

The rapid-growth sample support structure will be stowed in foam inside the experiment container when not in use. The rapid-growth sample support structure is constructed from 1/4 inch aluminum plate and exhibits a C-shaped cross-section.

The rapid-growth sample module is deployed by attaching it to the top of the upper horizontal member of the rapid-growth sample support structure with four captive 1/4-

20 screws. The MGBx PLS is attached to the lower horizontal portion (baseplate) via the PLS base. The baseplate has an integral steel strip for the purpose of interfacing with the magnet in the bottom of the PLS base. Holes in the baseplate (which straddle the integral steel strip) are arranged to allow the PLS base to be positioned in any of six locations corresponding to the centerlines of the five sample cuvettes and the reticle in the rapid-growth sample module.

The vertical portion of the structure separates the portable light source and the rapid-growth sample module by a fixed distance. The baseplate of the structure is attached to the floor of the MGBx with two experiment screws provided by the MGBx project. The screws will be flown as BCAT-2 stowage hardware.

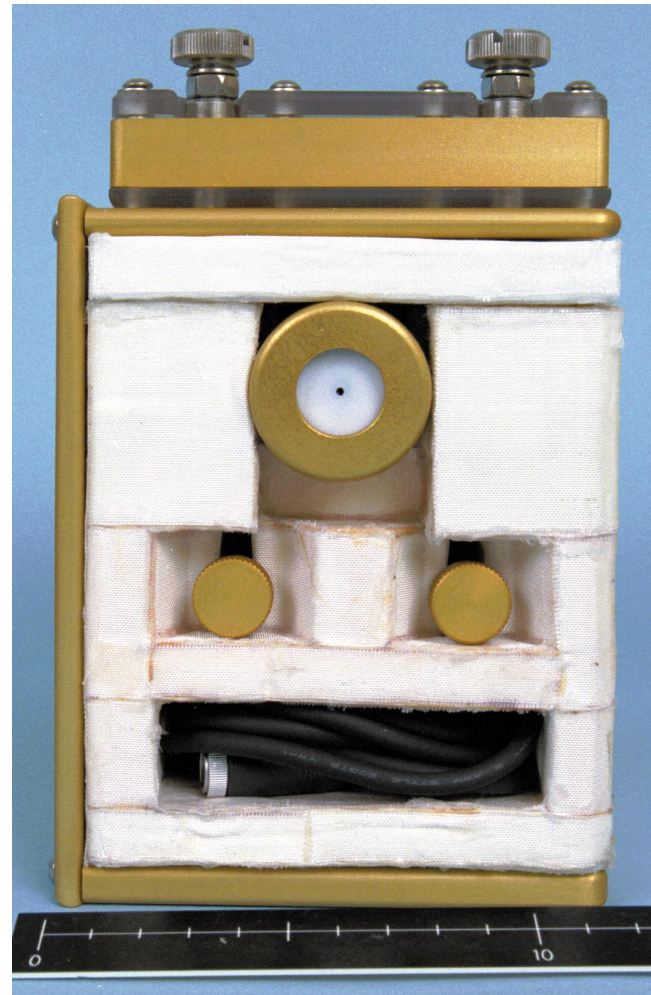

Figure MG-14 Rapid-Growth Sample Support S97-06690

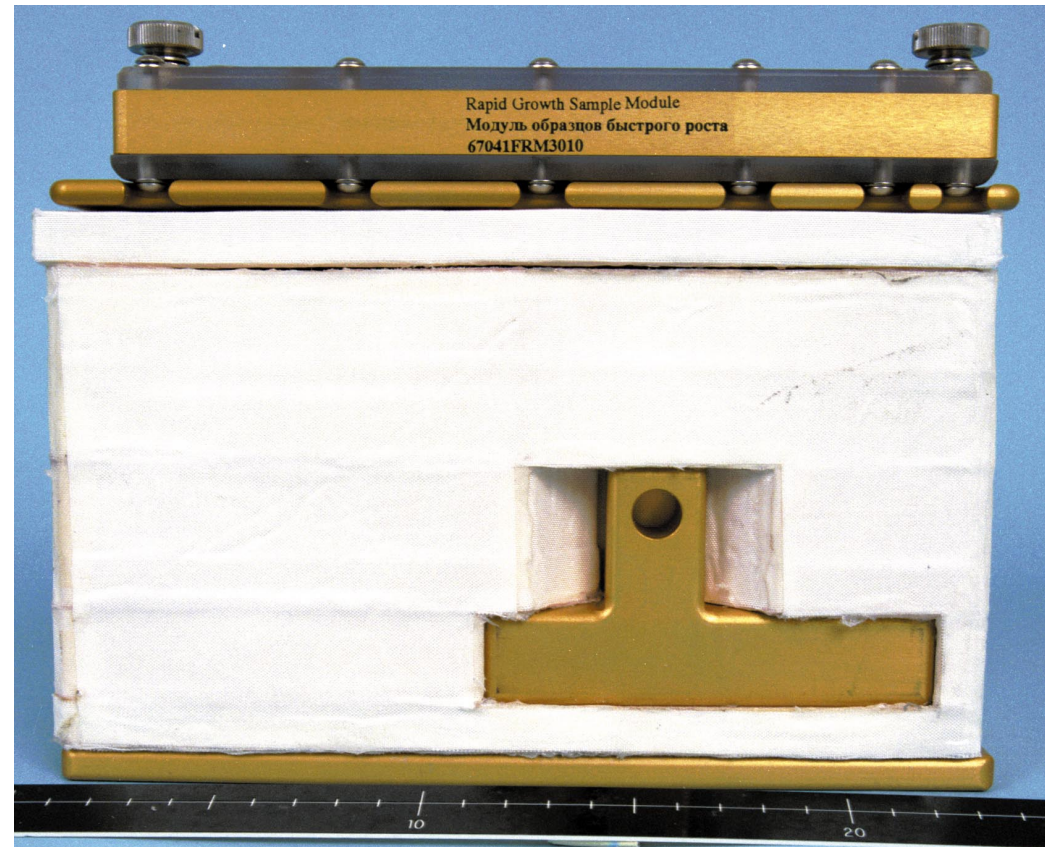

Figure MG-15 Front of the Rapid-Growth Sample Support Structure S97-06693



Figure MG-16 Right Side of the Rapid-Growth Sample Support Structure S97-06691

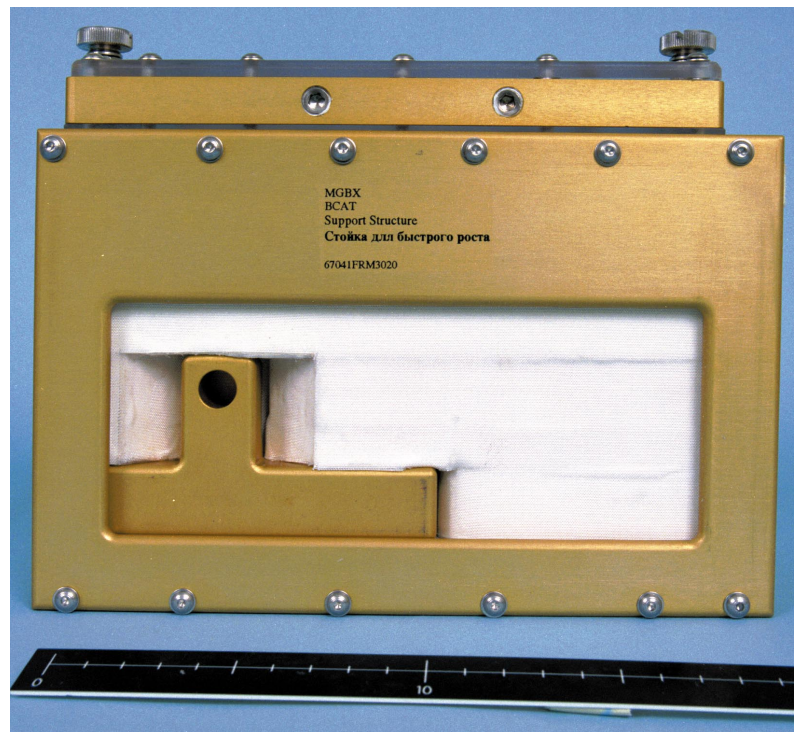

Figure MG-17 Back of the Rapid-Growth Sample Support Structure S97-06692

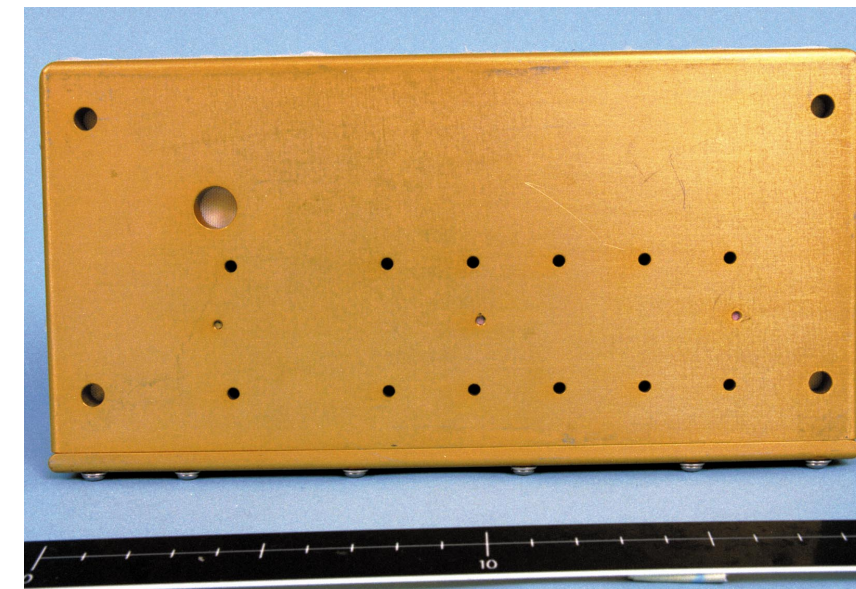

Figure MG-18 Bottom of the Rapid-Growth Sample Support Structure S97-06689



### Slow-Growth Sample Module

The slow-growth sample module is held captive in the slow-growth structure (which is housed inside the experiment container) at all times, except when it is removed briefly for experiment initiation. The slow-growth sample module exhibits the same design features as the rapid-growth sample holder, except it is configured to house ten sample cuvettes.

### Slow-Growth Structure

The slow-growth structure is rigidly fixed to the inside of the experiment container. The slow-growth structure includes a baseplate for attaching the 35mm camera, batteries, backlight, and slow-growth sample module to the experiment container.

### Control Module

The control module will be rigidly fixed in the slow-growth structure. The control module activates the backlights and camera for taking photographs of the slow-growth samples.

### Backlight Structure

The backlight structure will be rigidly fixed in the slow-growth structure. It provides backlighting for each of the 10 slow-growth samples.

### 35mm Camera with 250 Frame Databack

The camera will be rigidly fixed in the slow-growth structure, which will be housed inside the experiment container. Bragg scattering will be recorded via 35mm photography.

### Batteries

Two 6-volt batteries will be rigidly fixed in the slow-growth structure. One battery powers the lights and the other powers the slow-growth control module.

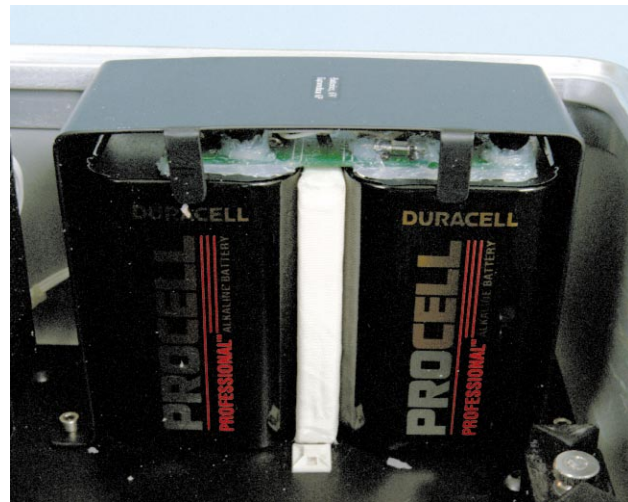

S97-06686

Figure MG-20 Slow Growth Backlight Structure

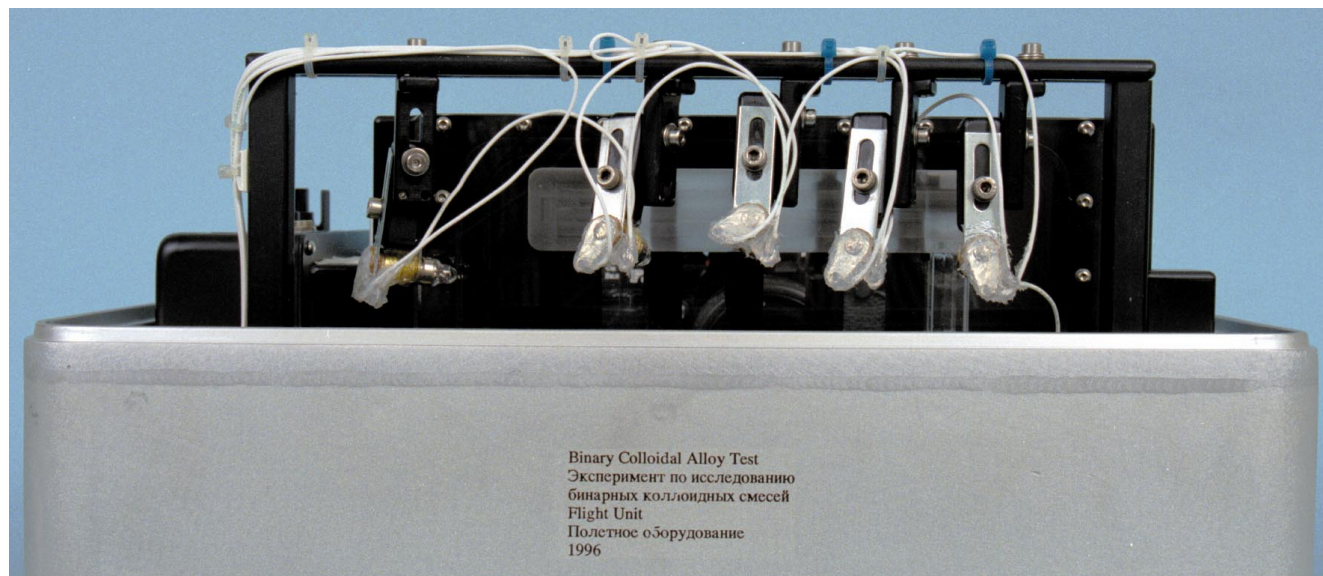

S97-06685

Figure MG-19 Slow Growth Batteries



S97-06684

Figure MG-21 Slow-Growth Sample Chamber Back



S97-06683

Figure MG-22 Slow-Growth Chamber

**PLS Base**

The PLS base will be stowed in foam inside the experiment container when not in use. The PLS base is a mounting attachment that is used to secure the MGBx PLS to the rapid-growth sample support structure. The PLS base is made of aluminum. It has two dowels on its bottom surface, which interface with matching holes (slip fit) in the base plate of the rapid-growth sample support structure. A small magnet will be inset into the bottom surface of the PLS base. This will magnetically interface with a steel strip which is integral to the baseplate of the rapid-growth sample support structure. A captive 1/4-20 screw on the side of the PLS base is used to secure the MGBX PLS to the PLS base.

**PLS Diffuser Cap**

The portable light source diffuser cap will be stowed in foam inside the experiment container when not in use. The portable light source diffuser cap is attached to the end of the MGBx portable light source to regulate the amount of light directed at the bottom of the rapid-growth sample module.

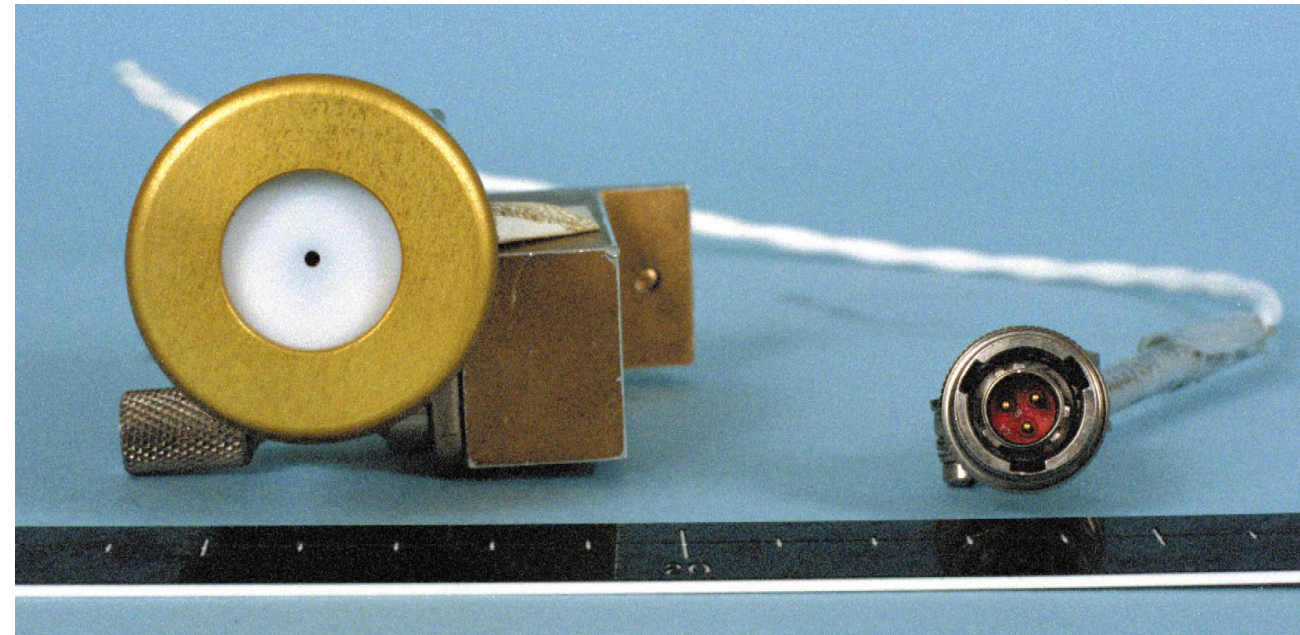

S97-01268

Figure MG-25 PLS Diffuser Top (Training)

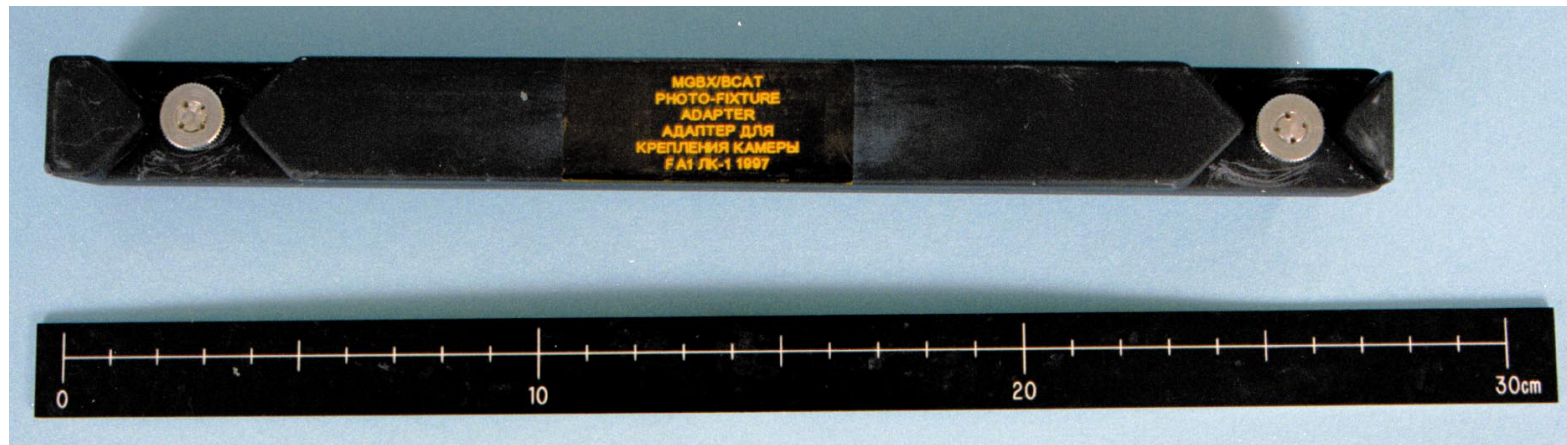

S97-06687

Figure MG-23 PLS Base Top

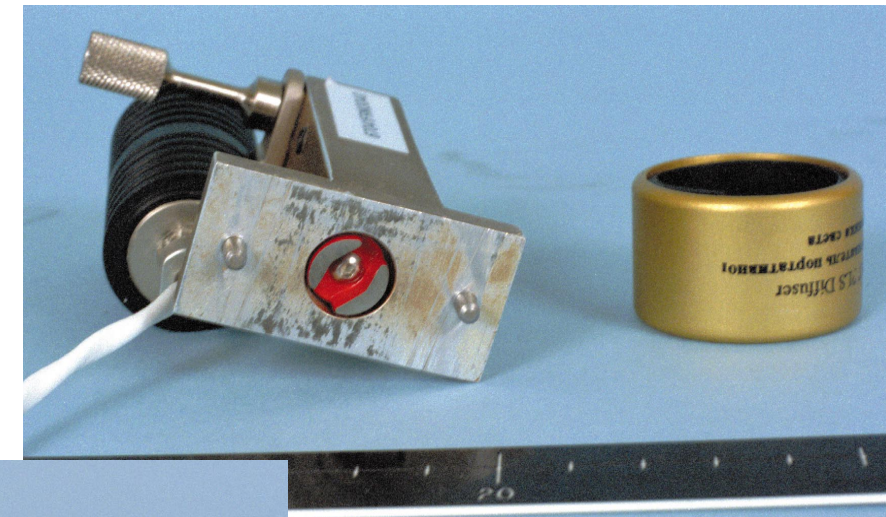

S97-01266

Figure MG-26 PLS Base (Training)

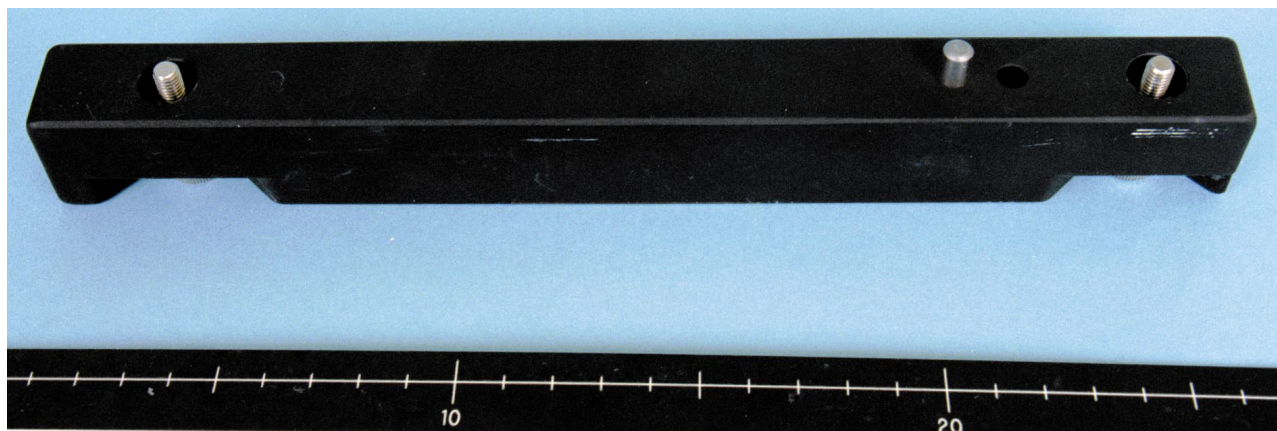

S97-06688

Figure MG-24 PLS Base Bottom

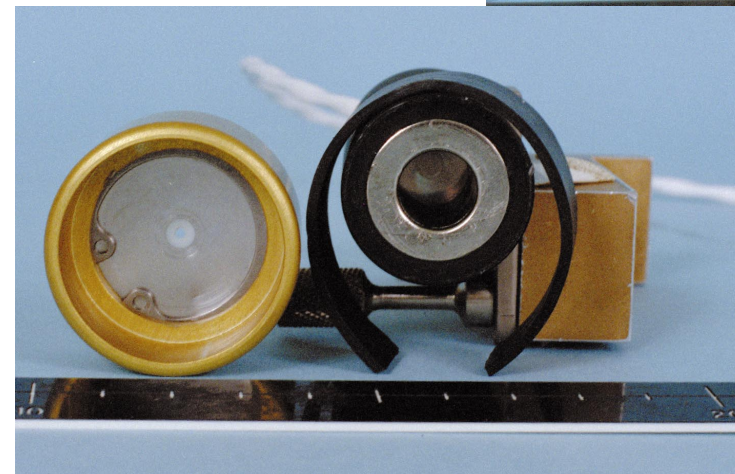

S97-01267

Figure MG-27 PLS Disassembled (Training)



## BCAT-2 Camera Head Adapter

The BCAT-2 camera head adapter will be stowed in foam inside the experiment container when not in use. The BCAT-2 camera head adapter is, in turn, attached to the Post Adapter Bracket Assembly during rapid-growth sample operations.

## BCAT-2 Video Camera

The BCAT-2 video camera will be stowed in foam inside the experiment container when not in use. The BCAT-2 video camera will be attached to the BCAT-2 camera head adapter.

The video camera will be connected to the MGBx DAVID, as required, to support video imaging of the Rapid-Growth Sample Module.

## 8mm Tapes

The 8mm tapes will be loaded into the MGBx Data Video Drawer Assembly (DAVID), as required, to support video imaging of the Rapid-Growth Sample Module.

## MGBx Experiment Screws

The MGBx experiment screws will be stowed in foam inside the experiment container when not in use. The screws are used to secure the Support Structure to the floor of the MGBx.

## Mixer

The mixer will be stowed in foam inside the experiment container when not in use. The mixer consists of a 24V DC explosion proof motor fitted with a magnet on the end of the motor shaft. The motor is housed in an acrylic tube which is held by the astronaut while mixing samples on orbit.

## HARDWARE INTERFACE WITH SYSTEMS

The BCAT-2 hardware has no electrical or data interfaces with the Mir Station. ✱

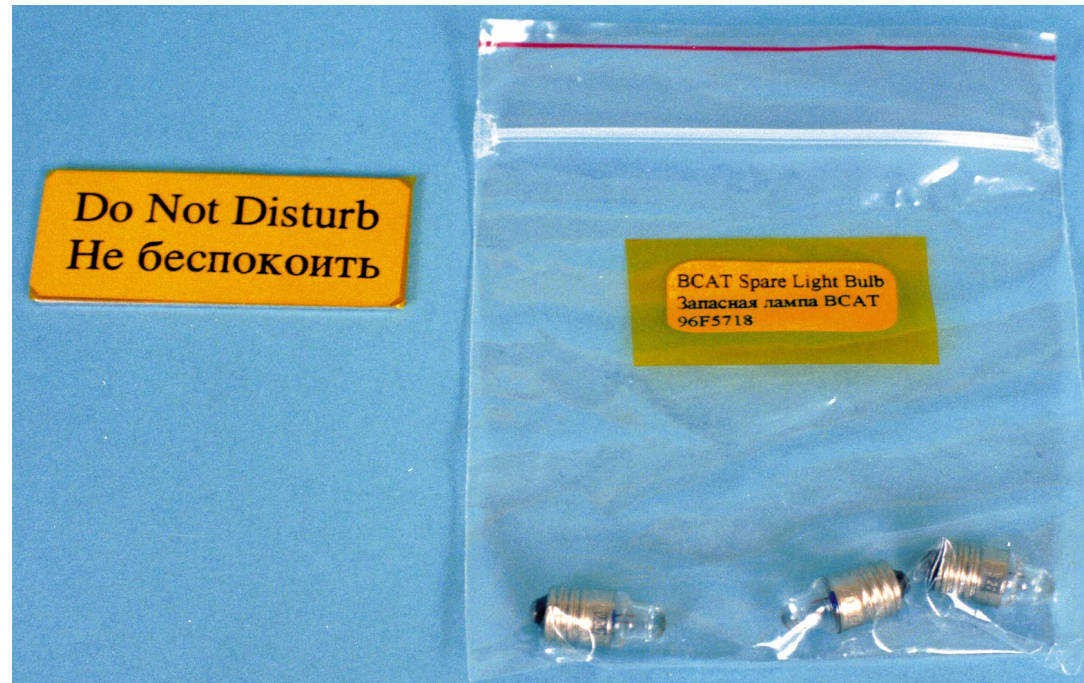

Figure MG-28 Spares

S97-06675

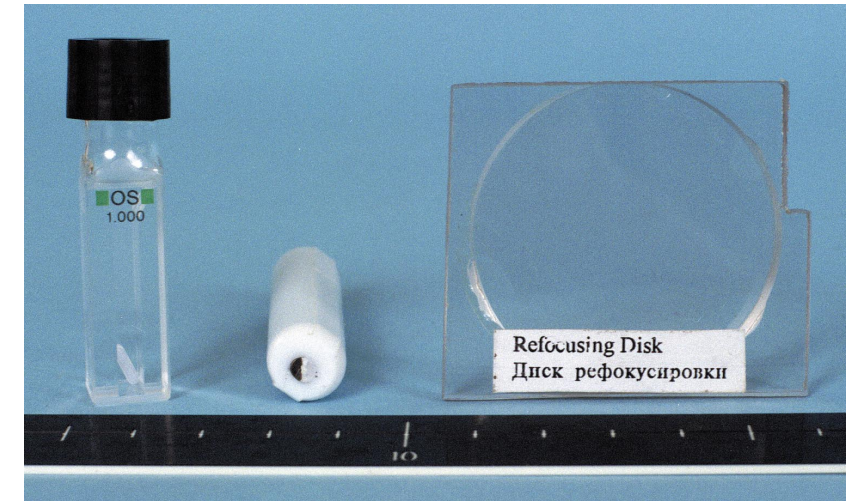

Figure MG-30 Accessories

S97-01265

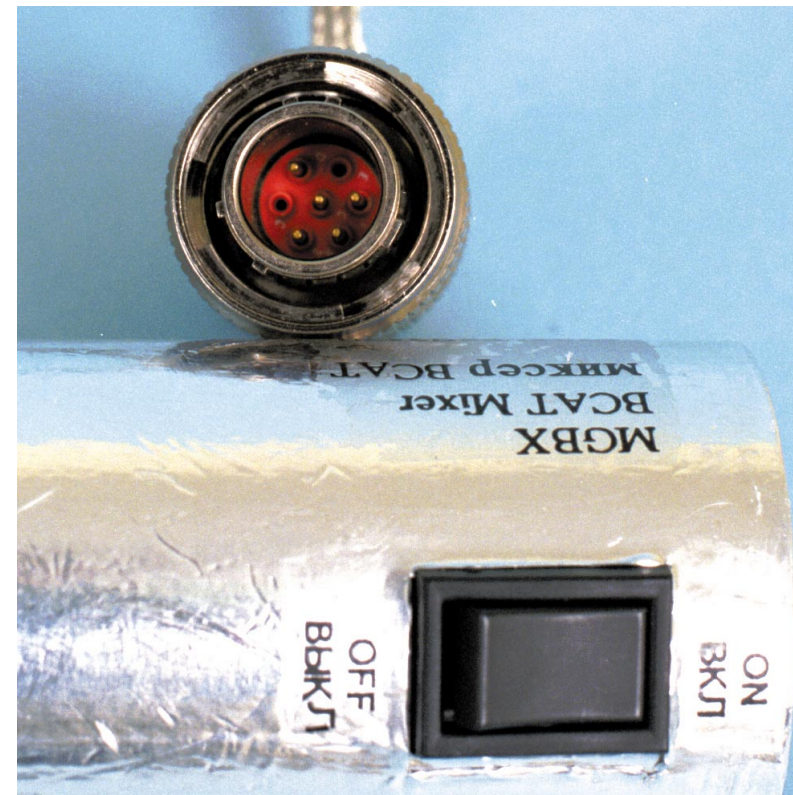

Figure MG-29 BCAT-2 Magnetic Stirrer Connector

S97-06674

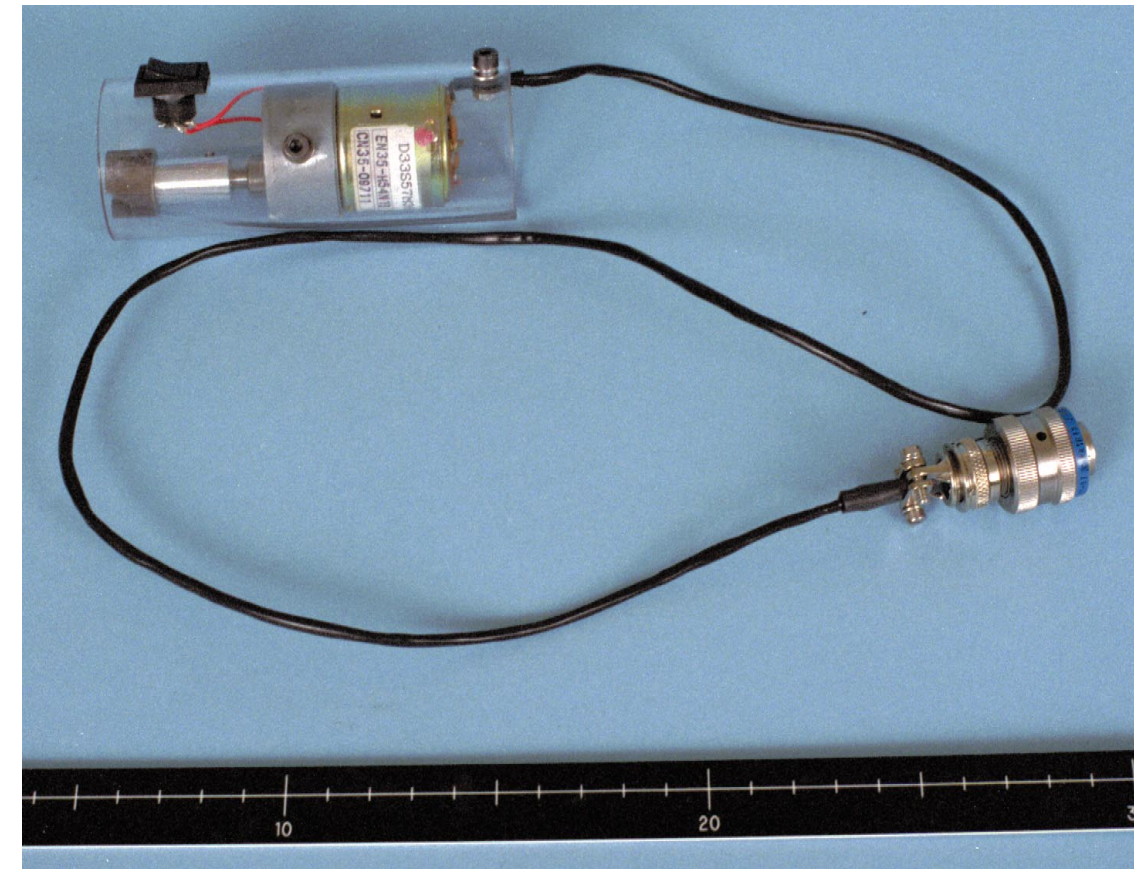

Figure MG-31 BCAT-2 Magnetic Stirrer (Training)

S97-01279



# BIO TECHNOLOGY SYSTEM (BTS) FACILITY OPERATIONS

## BTS GAS SUPPLY MODULE (GSM)

### GSM HARDWARE DESCRIPTION

The Gas Supply Module (GSM) is a Middeck locker-sized module that has the capability of supplying an air/carbon dioxide gas blend used to support tissue cultures. The GSM is capable of delivering a gas blend at  $40 \pm 4$  psig. The GSM contains three fiberglass filament wound composite cylinders rated at 3000 psig maximum working pressure. Each cylinder has an internal volume of 2.2 liters. For this increment, all three cylinders will be filled with a premixed gas mixture consisting of 10 percent CO<sub>2</sub>, 21 percent O<sub>2</sub>, and 69 percent N<sub>2</sub>. All 3 cylinders contain mixed gas. Cylinder 3 is currently empty.

In addition, the GSM contains valves, regulators, tubing, and quick disconnects.

A brief definition of the primary components for GSM is provided below.

#### **Pressure Switch**

The Pressure Switch sends pressure-induced electrical signal to the audible alarm that indicates pressure relief valve is near opening condition.

#### **Check Valve**

The Check Valve maintains one-way gas flow.

#### **Pressure Gauge**

The Pressure Gauge is an analog pressure indicator.

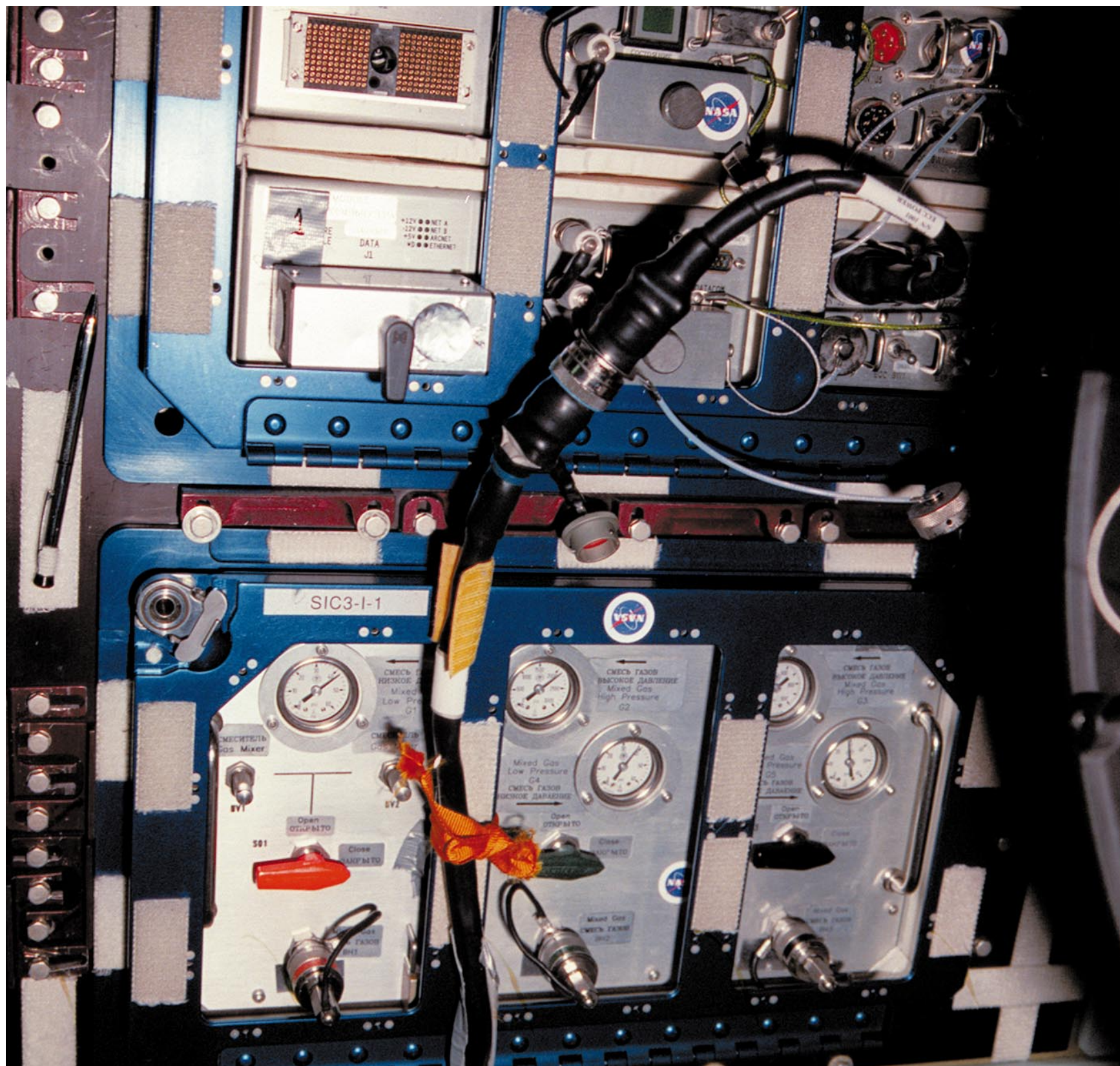

D.I.D.

Gas Supply Module

**Principal Investigator:**  
Steve Gonda, Ph.D.  
NASA/JSC/SD4  
(281)483-8745

#### **GAS SUPPLY MODULE**

P/N: SED46107313-301  
Qty: 1  
Mass: 23.7 kg  
Power: Battery  
x,y,z: 56.7 x 44.5 x 25.6 cm  
Loc: Priroda, SIC3-I-1  
DID#: SLM46111516

NM23-107-06

Figure MG-32 ECC and GSM in Priroda



## Flow Restrictor

The Flow Restrictor maintains gas flow rate at a specified maximum value.

## Gas Cylinder

The Gas Cylinder stores high-pressure gas.

## Alarm Test Switch

The Alarm Test Switch tests sonalert circuit and battery and turns on/off over-pressure alarm circuit.

## Regulator

The Regulator maintains constant pressure on the downstream (or low pressure) side.

## Metering Valve

The Metering Valve is an adjustable valve that permits various gas flow rate settings (preset prior to launch based on requirements for first experiment).

## Shutoff Valve

The Shutoff Valve is a manually operated valve.

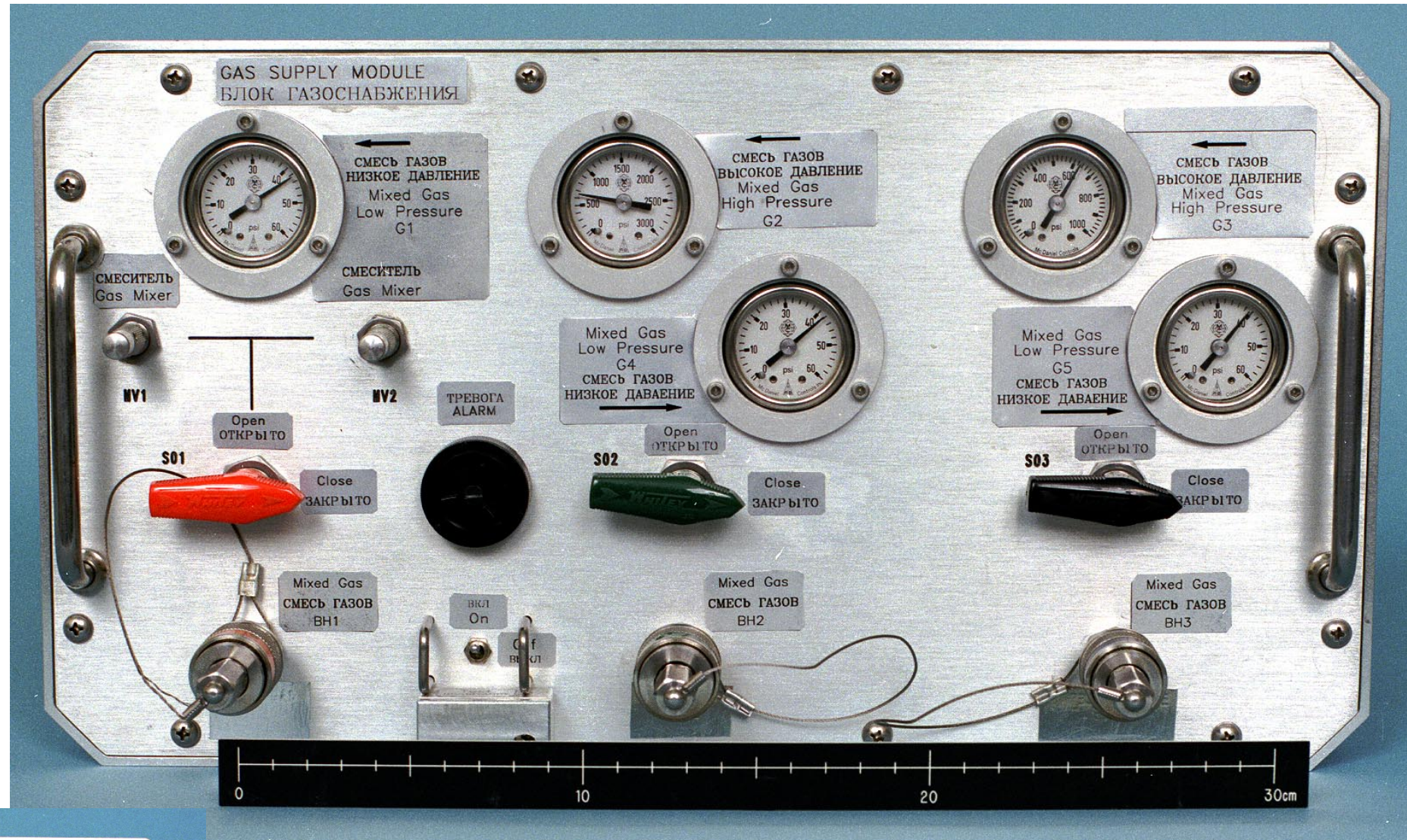

Figure MG-34 BTS GSM Front Panel (Training)

S97-06380

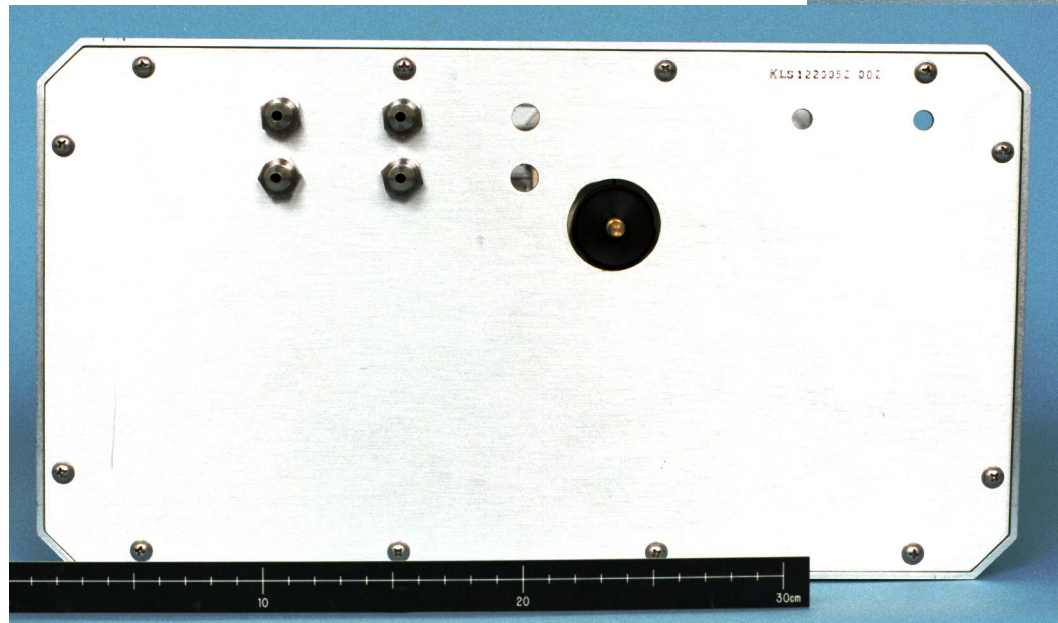

Figure MG-33 BTS GSM Back (Training)

S97-06379

## Relief Valves

The Relief Valves are automatic valves that are set to open at a specified maximum pressure.

## GSM HARDWARE INTERFACE WITH SYSTEMS

- The GSM requires no external electrical power.
- The GSM contains an internal alkaline battery to power the audible pressure alarm.

## GSM DISPLAYS AND CONTROLS

See Table MG.1 for GSM Indicators and Controls.



**TABLE MG.1  
GSM INDICATORS AND CONTROLS**

Panel Nomenclature	Type of Feature	Description	Function/Significance
<b>GAS SUPPLY MODULE</b>			
G1 MIXED GAS LOW PRESSURE	Mixed gas (Air/CO <sub>2</sub> ) pressure gauge	Bourdon Tube Analog Gauge	Analog reading of pressure in mixed gas outlet line to experiment
G2 MIXED GAS HIGH PRESSURE	Mixed gas (Air/CO <sub>2</sub> ) pressure gauges (two)	Bourdon Tube Analog Gauge (two)	Analog reading of pressure in mixed gas cylinder (outlet line)
G4 MIXED GAS LOW PRESSURE			
G3 MIXED GAS HIGH PRESSURE	Mixed gas (Air/CO <sub>2</sub> ) pressure gauges (two)	Bourdon Tube Analog Gauge (two)	Analog reading of pressure in mixed gas cylinder (outlet line)
G5 MIXED GAS LOW PRESSURE			
S01	Mixed gas manual shut-off valve	Quarter-turn valve handle	OPEN (CLOSE) indicates flow (no flow) of mixed gas
S02	Manual shut-off valve	Quarter-turn valve handle	OPEN (CLOSE) indicates flow (no flow) of mixed gas
S03	Manual shut-off valve	Quarter-turn valve handle	OPEN (CLOSE) indicates flow (no flow) of mixed gas
BH1	Mixed gas quick disconnect	Gas port connector	Distribute mixed gas to experiment
BH2	Mixed gas quick disconnect	Gas port connector	Distribute mixed gas to experiment
BH3	Mixed gas quick disconnect	Gas port connector	Distribute mixed gas to experiment
MV1 MIXED GAS MIXER	Multi-turn thumb-knob	Metering valve	Variable orifice to control mixed gas flow rate — preset prior to launch based on requirements for first experiment
MV1 GAS MIXER	Multi-turn thumb knob	Metering valve	Variable orifice to control mixed gas flow rate-preset prior to launch based on requirements for first experiment
MV2 GAS MIXER	Multi-turn thumb knob	Metering valve	Variable orifice to control mixed gas flow rate-preset prior to launch based on requirements for first experiment
ALARM TEST SWITCH	ON/OFF/TEST	Three position toggle	On/Off indicates alarm system active/not active TEST Alarm (momentary) test system

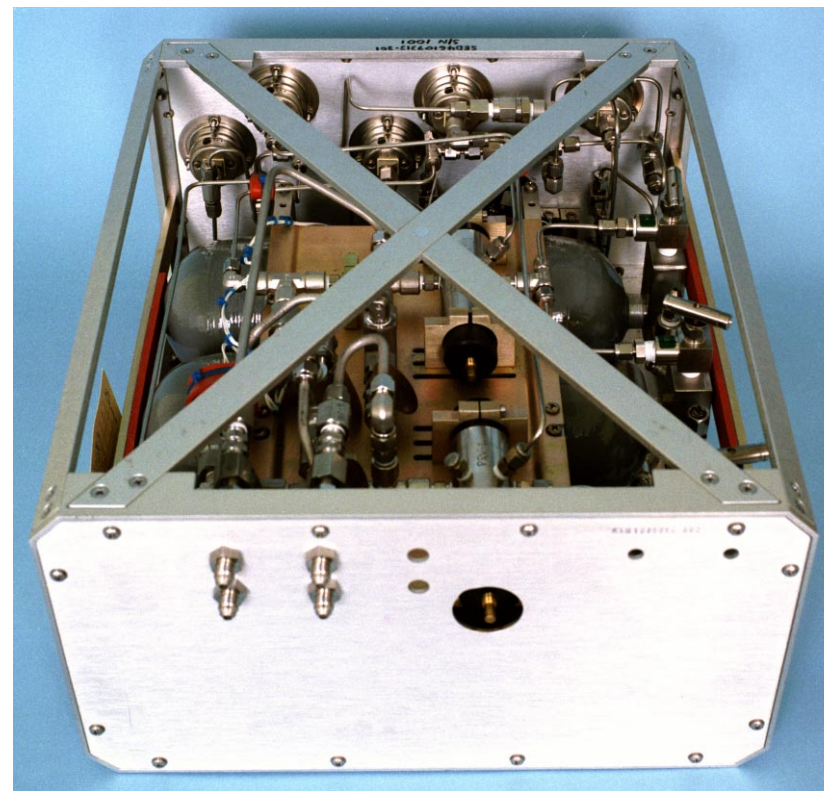

Figure MG35 GSM Rear and Top

S97-06378

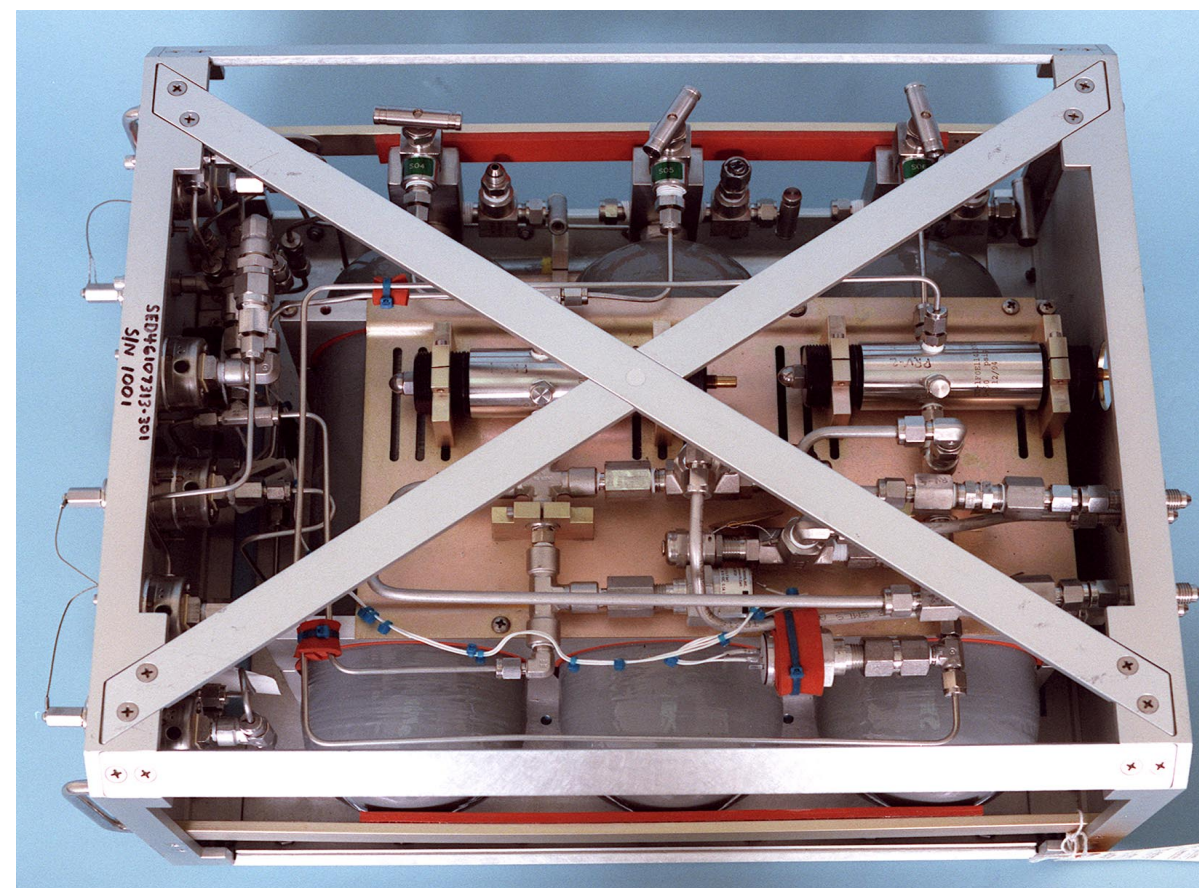
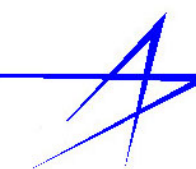

Figure MG-36 GSM Interior

S97-06377



## BTS COMPUTER MODULE (BCM)

### BCM HARDWARE DESCRIPTION

The BCM hardware provides crew interface, experiment control, power distribution, and data acquisition for the cell culture experiments supported by the BTS. The BCM is cooled with cabin air. Internal fans circulate air within the equipment case and exhaust through the rear of the locker. BCM Interface Options are described in Table MG.4.

The BCM has the capacity to carry two Experiment Control Computers (ECCs), each of which occupies one-half of a Priroda Single Stowage Locker.

### Experiment Control Computer (ECC)

An ECC is composed of a Control Module and a Power Module. The Increment 7 configuration consists of two ECCs.

### Experiment Control Module (ECM)

The ECM is an experiment-dedicated 486DX66 computer that contains two custom interface cards that provide all of the interface options listed below for the use of the experiment.

A high-density, multi-pin connector on the front panel connects the Control Module to the experiment.

On the front panel are the programmable LCD push button status switch, the Personal Computer Memory Card International Association (PCMCIA) slots (Drive A, and Drive B), the Ethernet and ARCNET connectors (not used for Mir operations), and the ECC status Light-Emitting Diodes (LEDs).

### Power Module

The Power Module receives 27 +5/-4V DC power from the PUP.

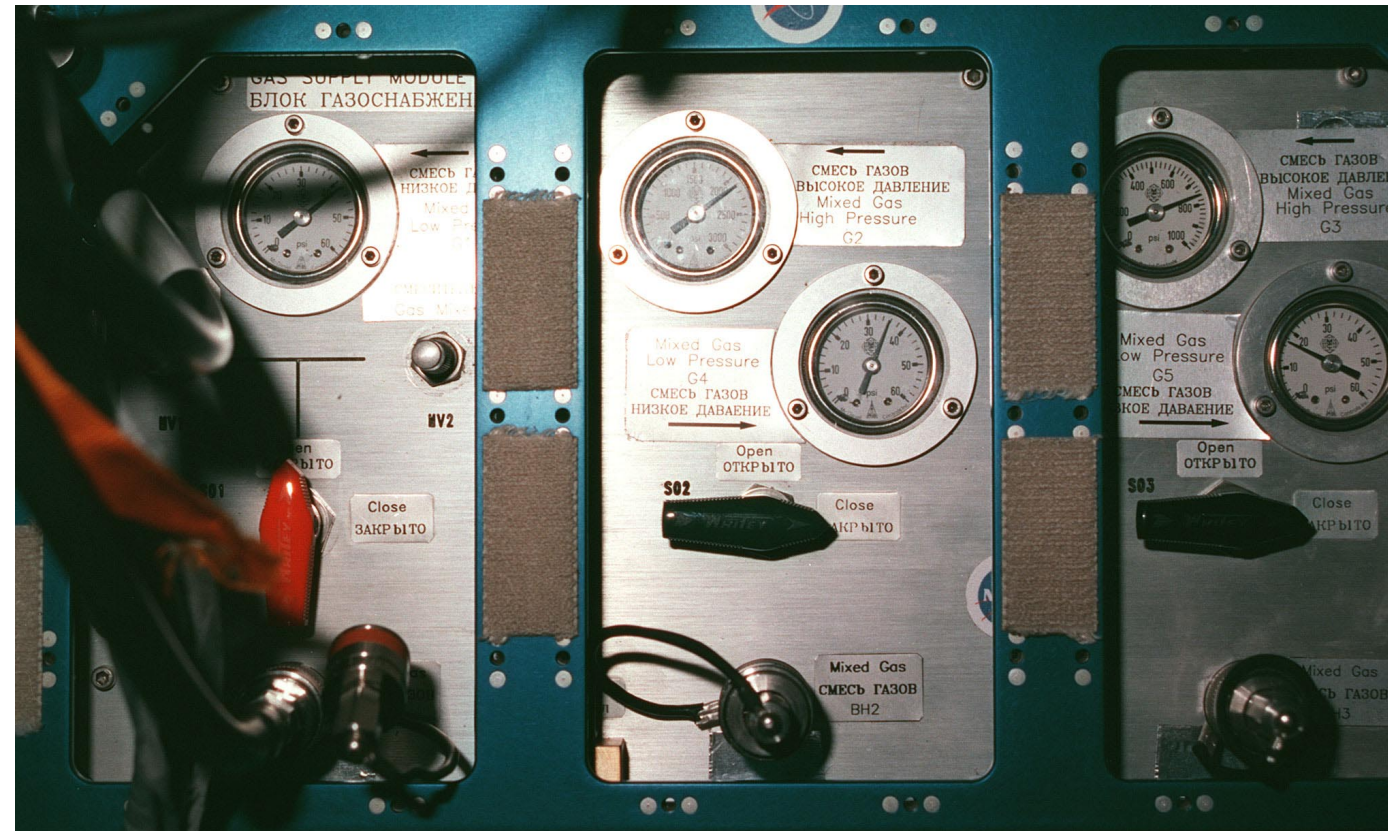

Figure MG-38 BCM Front Panel

NM22-060-09

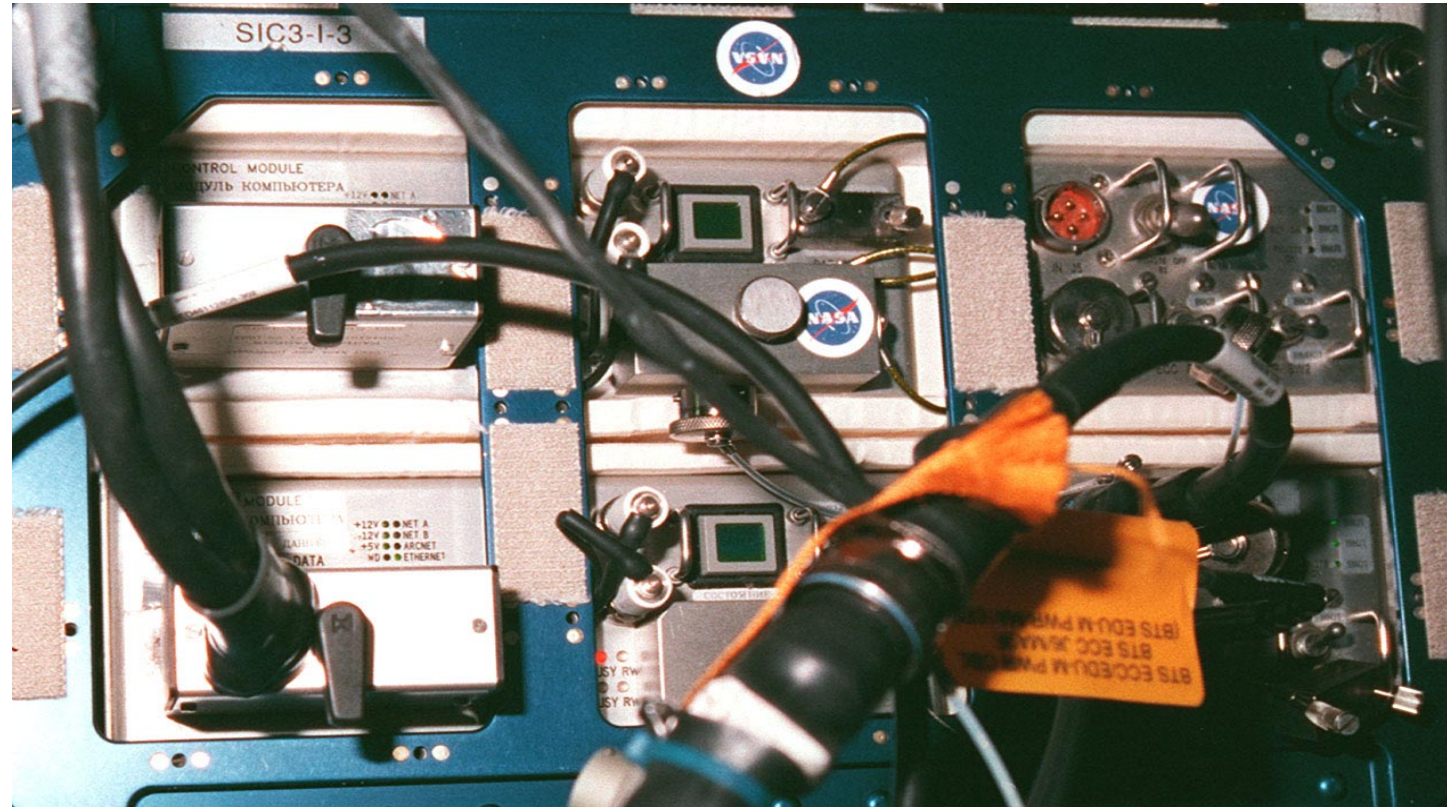

Figure MG-37 ECC in Priroda

NM22-060-08

### BCM HARDWARE INTERFACE WITH SYSTEMS

The BCM interfaces with the BTS Experiment Module (BEM), providing data capability and power per connectors J1 and J5.

### BCM DISPLAYS AND CONTROLS

See MG-38 for BCM Front Panel. See Tables MG.2 and MG.3 for BCM Indicators and Controls.

### BTS EXPERIMENT MODULE (BEM)

### BEM HARDWARE DESCRIPTION

The BEM is a Middeck locker equivalent volume within the BTS

facility in which experiment-specific hardware is integrated and operated. Power and gasses are supplied to the BEM by the BCM, and GSM, respectively.

### BTS STOWAGE MODULE (BSM)

### BSM HARDWARE DESCRIPTION

The BSM hardware launched on Priroda houses generic items used for facility maintenance and experiment support. There are three BSMs launched on Priroda.

The three BSMs contain passive stowage items.

### BSM HARDWARE INTERFACE WITH SYSTEMS

- The BSM requires no electrical power.
- The BSM requires no heat rejection. ✱

D.I.D.

BioTechnology  
Experiment Module

D.I.D.

BioTechnology Systems  
Computer Module

### EXPERIMENT CONTROL COMPUTER (ECC) FOAM ASSEMBLY

P/N: SED46112606-303  
Qty: 1  
Mass: 1.27 kg  
Power: 0  
x,y,z: 51.61 x 43.97 x 12.32 cm  
Loc: Priroda  
DID# SLM46111518

### CONTROL MODULE ASSEMBLY (with foam is the ECC)

P/N: SED46107305-306  
Qty: 1  
Mass: 4.86 kg  
Power: 0  
x,y,z: 48.26 x 24.64 x 8.51 cm  
Loc: Priroda  
DID# SLM46111518

### POWER MODULE ASSEMBLY

P/N: SED46107310-308  
Qty: 1  
Mass: 3.12 kg  
Power: 60 W  
x,y,z: 48.26 x 13.21 x 8.51 cm  
Loc: Priroda  
DID# SLM46111518



TABLE MG.2  
ECC INDICATORS AND CONTROLS-CONTROL MODULE

Panel nomenclature	Type of feature	Description	Function/significance
CONTROL MODULE			
DATA J1	Experiment Interface Connector	220-pin connector	Experiment data cable interface
DATA COM J4	RS-232 data connector	Pin-type data connector	For use with external computer
STATUS	Liquid crystal display	Momentary push-button with display	Displays ECC and experiment diagnostic codes; push to acknowledge
DRIVE A DRIVE B	PCMCIA Drives — two  PCMCIA Drive A (B) Busy (two)	PCMCIA card slots (two)  Right white LED (one per drive)	Stores facility and experiment programs and data  Indicates access to PCMCIA card in Drive A (B)
NOT LABELED	PC-card eject buttons (one each Drive)	Push-to-eject buttons (one per drive)	Ejects PC card installed in Drive A (B)
ETHERNET J2	Ethernet connector	Network interface connector	Not used; Terminator in place
ARCNET J3	ARCNET Connector	Network interface connector	Not used; Terminator in place
+12V, -12V, +5V	+12 V, -12 V, +5 V Power (three)	Green LEDs (one each)	ON indicates +12, -12, +5 Vdc power available to ECC
WD	Watchdog Activity Timer Indicator	Green LED	OFF indicates nominal; blinks when automatic reset occurs
NET A NET B	Internal ARCNET status (two)	Green LEDs (one each)	Not used
ARCNET ETHERNET	ARCNET, Ethernet Status (two)	Green LEDs (one each)	Not used

TABLE MG.3  
ECC INDICATORS AND CONTROLS-POWER MODULE

Panel Nomenclature	Type of Feature	Description	Function/Significance
POWER MODULE			
IN J5	PUP Input Power Interface	Pin-type power connector	27 (+5/-4) Vdc power feed from PUP
OUT J6	Experiment power interface	Pin-type power connector	27 (+5/-4) Vdc power feed to experiment equipment (not used until experiment installed)
REMOTE OFF S3	ECC control of experiment power	Two-position toggle	ON indicates experiment power remote control enabled (ECC controls EXP power), OFF indicates disabled
ECC SW 1	ECC ON/OFF toggle switch	Two-position toggle	ON indicates control module power enabled, OFF indicates power disabled to both experiment and ECC
EXP SW 2	Experiment Power Switch	Two-position toggle	ON indicates 27 (+5/-4) Vdc to experiment, OFF indicates no power to experiment
ECC ON	ECC power ON/OFF indicator light	Green LED	ON indicates power available to ECC (+5,+12,-12 Vdc)
EXP ON	Experiment status indicator light	Green LED	ON indicates 27 (+5/-4) Vdc power available at J6 connector (power to experiment)
REMOTE ON	ECC Remote Power Indicator light	Green LED	ON indicates that REMOTE OFF S3 switch is in ON position and that ECC can shut off experiment power

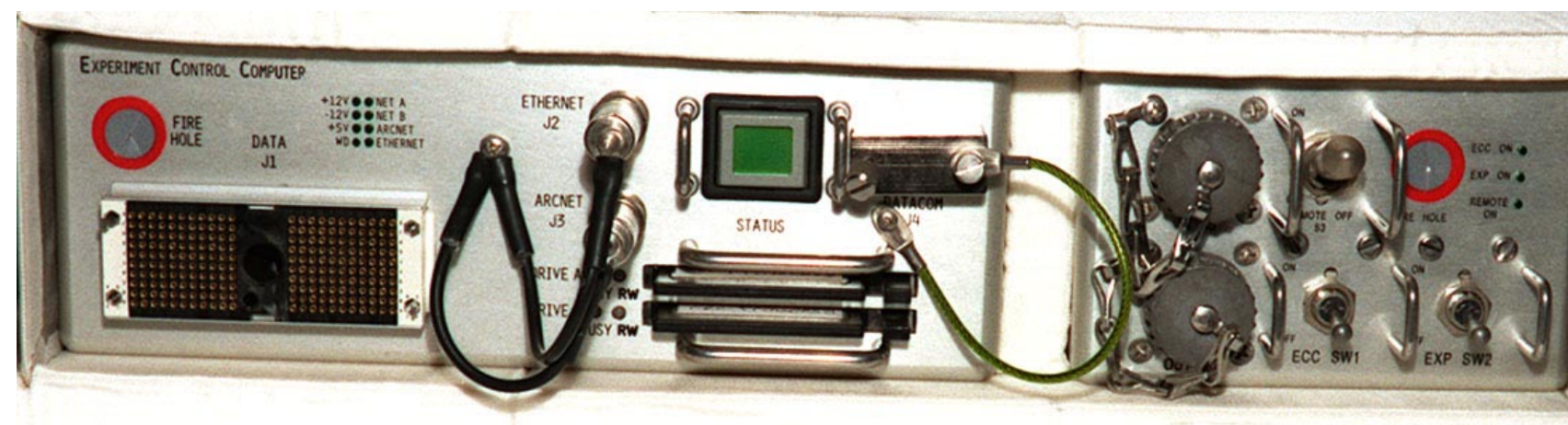

Figure MG-39 ECC (Control Module on Left and Power Module on Right)

S96-10901



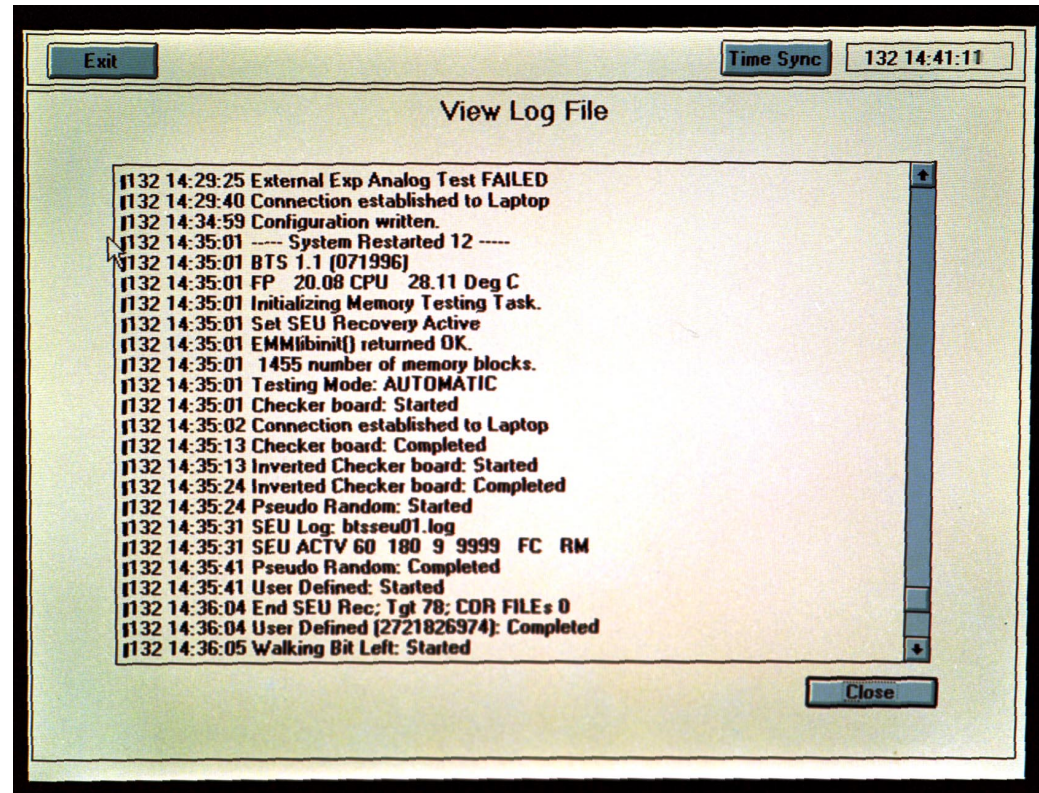

Figure MG-40 MIPS BTS View Log Screen

S97-06382

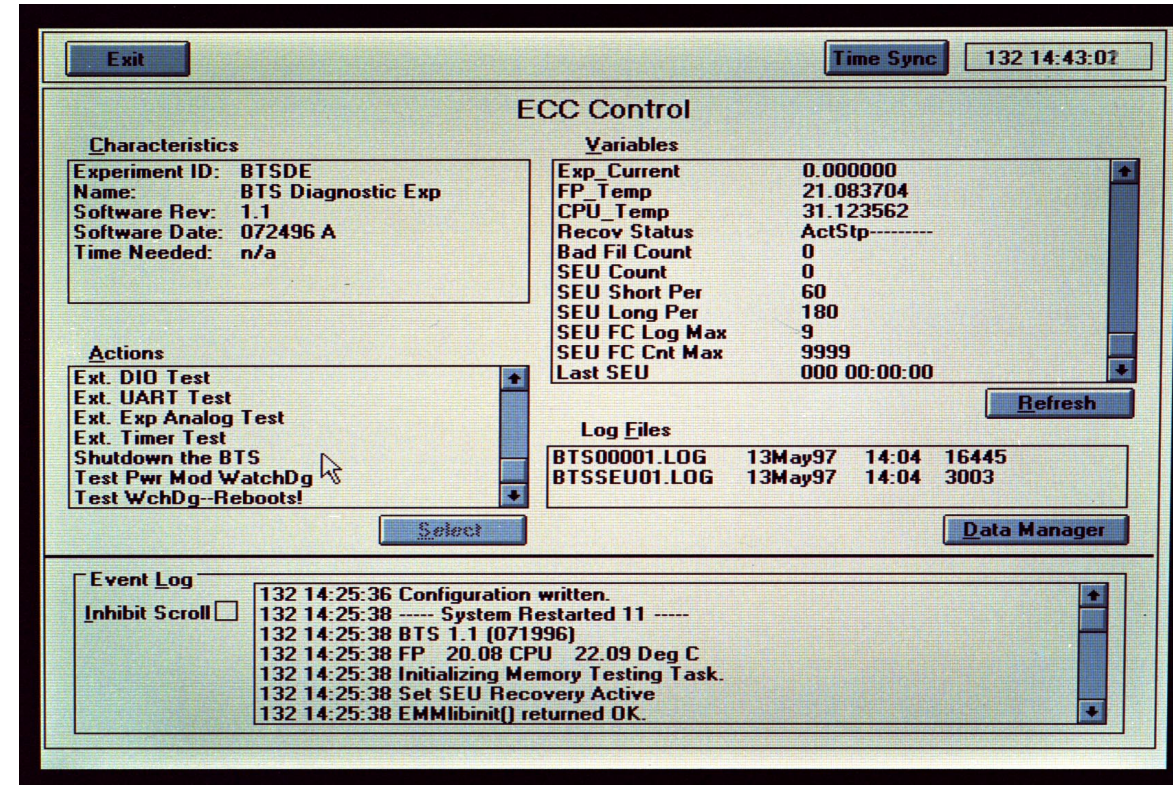

Figure MG-41 MIPS BTS ECC Screen

S97-06381

TABLE MG.4  
THE BCM INTERFACE OPTIONS (PER ECC)

<ul style="list-style-type: none"> <li>• DATACOM J4 - Laptop or Station On-Board Computer Interface (RS-232)</li> </ul>
<ul style="list-style-type: none"> <li>• DATA J1 <ul style="list-style-type: none"> <li>- 2 RS-232 Interfaces</li> <li>- 2 RS-422/485 Interfaces</li> <li>- 48 Software-Switchable Discrete Channels Digital Input/Output</li> <li>- 16 Discrete Channels Analog Output from Experiment</li> <li>- 2 Discrete Channels Analog Input to Experiment</li> <li>- 1 SCSI Interface (25-pin configuration)</li> <li>- 6 Timer/counter channels</li> </ul> </li> </ul>
<ul style="list-style-type: none"> <li>• 2 Type II PCMCIA data disk drives</li> </ul>
<ul style="list-style-type: none"> <li>• 1 ARCNET interface (not used for Mir operations)</li> </ul>
<ul style="list-style-type: none"> <li>• 1 Ethernet interface (not used for Mir operations)</li> </ul>
<ul style="list-style-type: none"> <li>• 1 Programmable LCD push-button status switch</li> </ul>

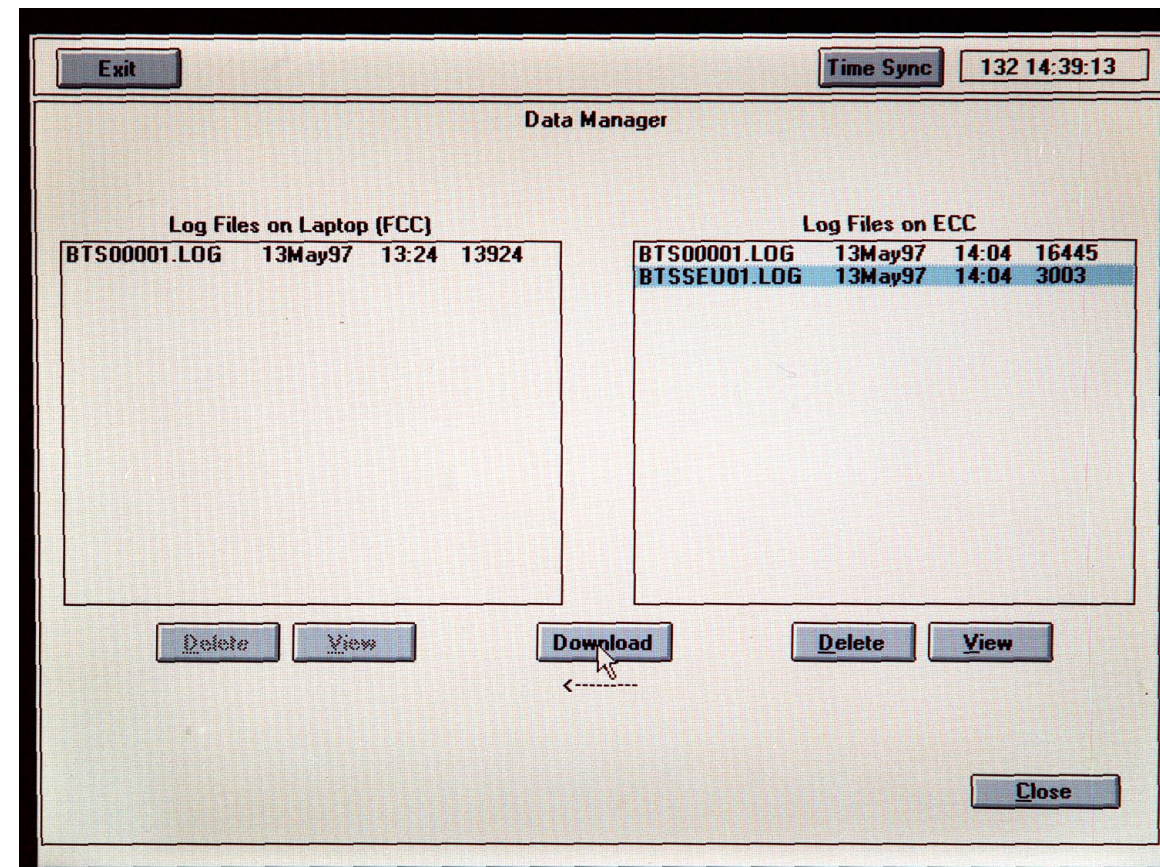

Figure MG-42 MIPS BTS Control Screen

S97-06371



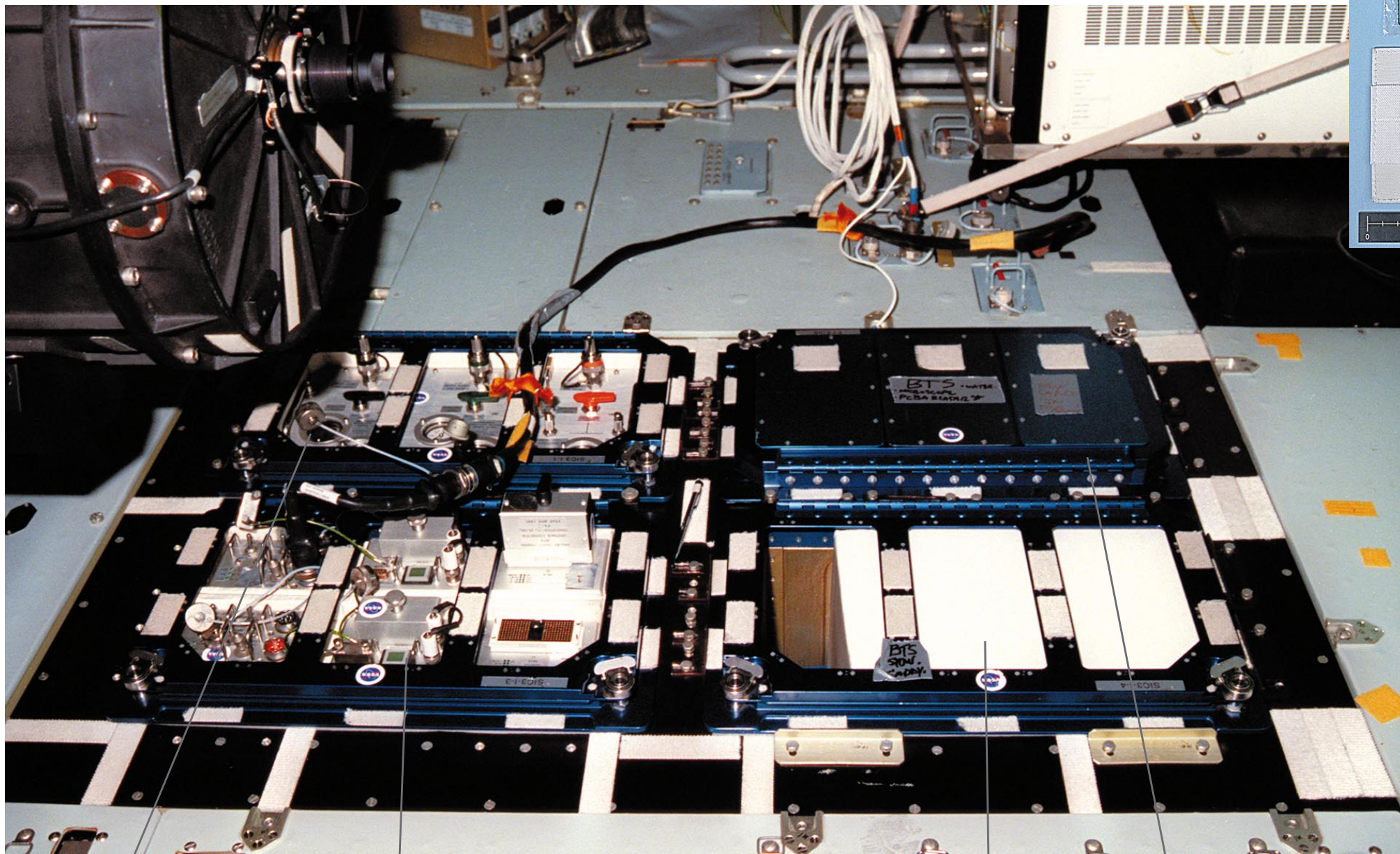

Figure MG-43 BTS in Priroda

NM23-107-09

ECC will be here for Inc. 7

GSM will be here for Inc. 7

EDU-M Locker

BTR Locker

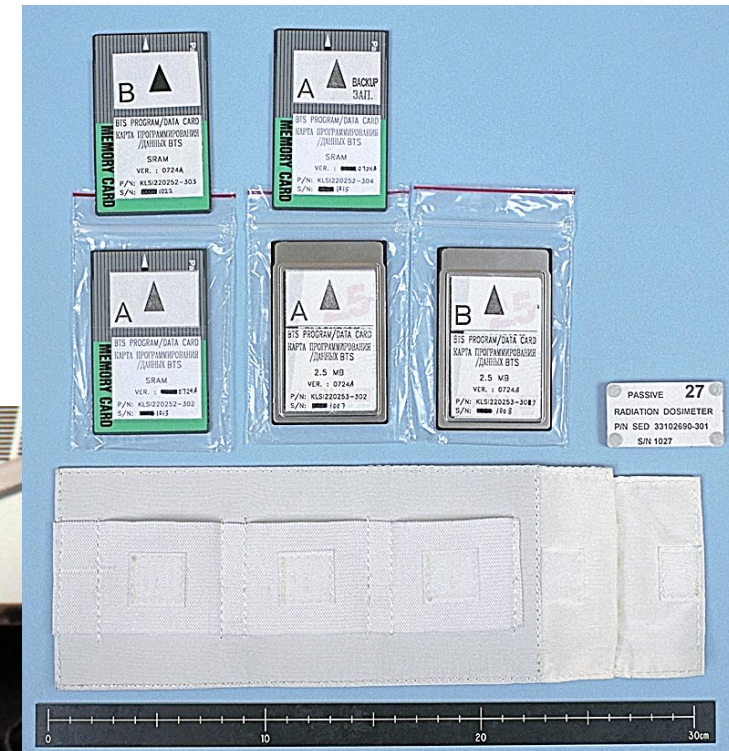

Figure MG-44 BTS PCMCIA Cards S97-17403



Figure MG-45 BTS PCMCIA Card S96-12118

**NOTE:** BTS-COCULT PCMCIA Cards are for running the experiment. They will be replaced with BTS Program/Data cards if a BTS functional checkout is performed.

**POWER CABLE ASSEMBLY (ECC TO BEM)**

P/N: SED46107316-701  
 Qty: 1  
 Mass: 20 kg  
 Power: N/A  
 x,y,z: 104.5 x 2.77 cm  
 Loc: Priroda, SIC-I-1a

**ECC POWER ADAPTER CABLE**

P/N: KLSI240720-701  
 Qty: 1  
 Mass: .18 kg  
 Power: N/A  
 x,y,z: 35 x 3.3 cm  
 Loc: N/A  
 DID#: SLM46111518





# Biotechnology System Priroda Operational Configuration NASA 7

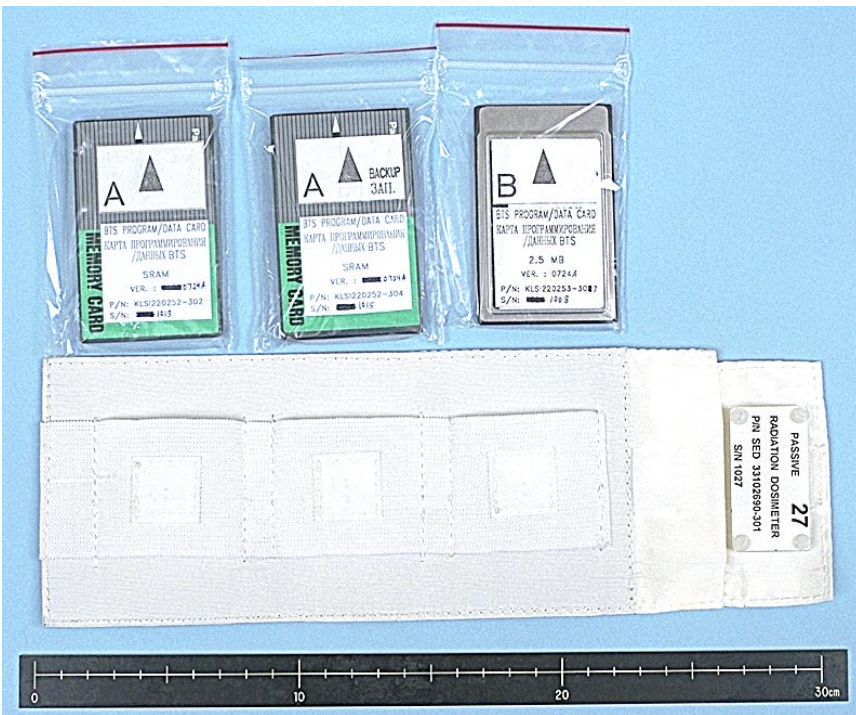

Figure MG-46 BTS PCMCIA Cards

S97-17402

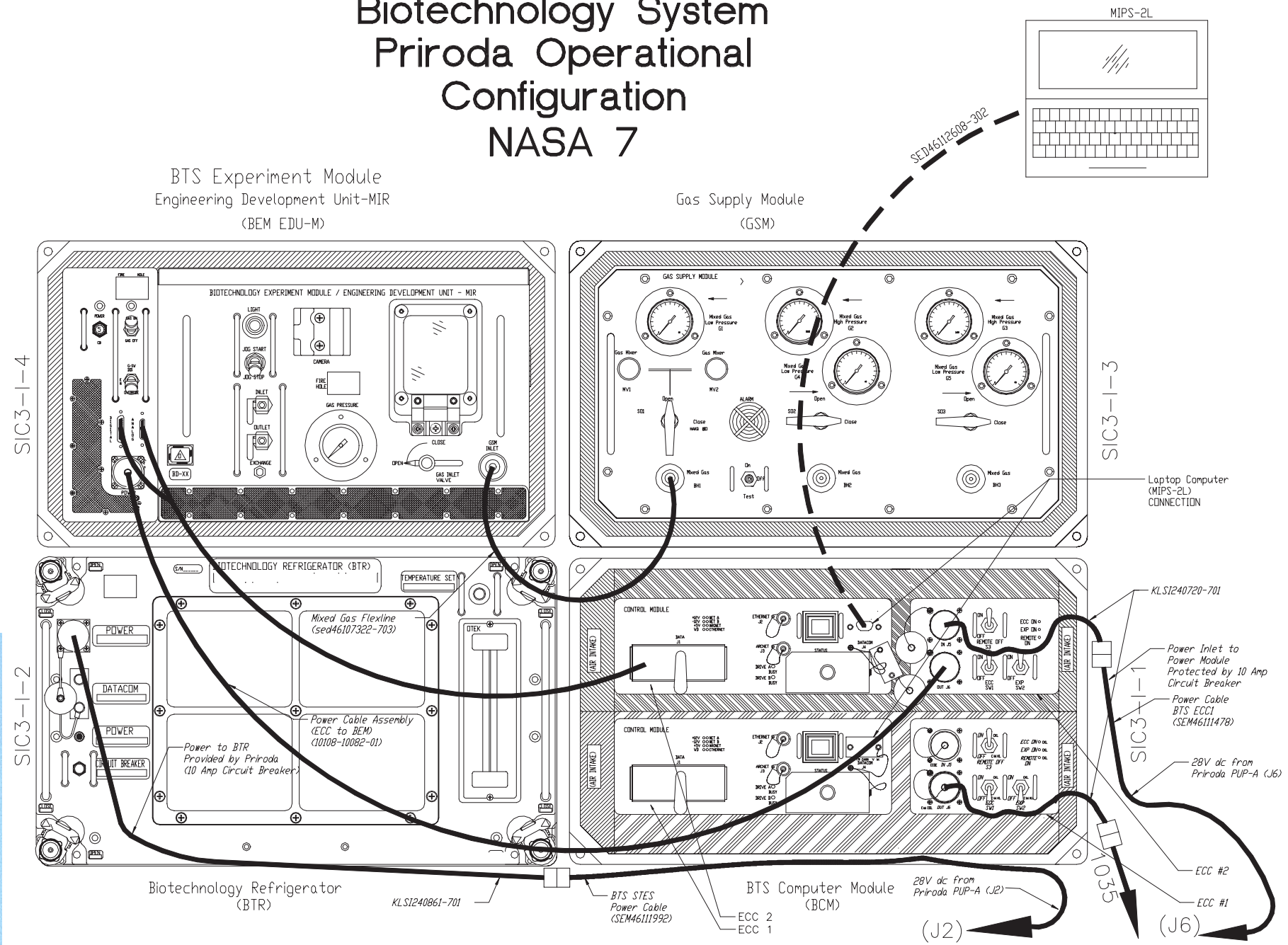

Figure MG-47 BTS NASA 7 Configuration



# BIOTECHNOLOGY SYSTEM BIOCHEMISTRY OF 3-DIMENSIONAL TISSUE ENGINEERING (BTS-BIO3D)

investigations on board Mir. BTS-BIO3D occupies a total of 3 locker volume equivalent. A Middeck locker location contains the BioTechnology Specimen Temperature Controller-Mir (BSTC-M). The BSTC-M is a locker replacement. Other BTS-BIO3D hardware is located in the SpaceHab module. The following BTS-BOI3D hardware is located in the SpaceHab module and flown on Mir:

- BSTC-M (1 Locker replacement)
- Ambient Stowage (1 Locker of experiment supplies)
- BioTechnology Refrigerator (BTR) (1 Locker replacement)

## POWER

BSTC-M requires approximately 122W peak and nominal power. This can be much lower with the unit in the incubation mode.

The BTR requires approximately 177W peak and nominal power. These values are dependent upon ambient temperature, the set point, and input voltage.

## EXPERIMENT DESCRIPTION

This investigation will investigate basic cell-to-cell interactions in a quiescent cell culture environment and their role in the formation of functional cell aggregates.

## SCIENCE OBJECTIVES

The objective of the Biochemistry of 3-Dimensional Tissue Engineering (BTS-BIO3D) experiment is to investigate the utility of the microgravity environment to enhance and support the formation of three-dimensional, functional, tissue-like equivalents.

## FUNCTIONAL OBJECTIVES

Cell cultures were transported to the Mir in the BSTC-M and integrated into the BEM (Biotechnology Experimental Module) of the BTS. Culture periods vary with light microscopy and photography monitoring throughout. Samples are stored at low temperatures or fixed for return to Earth for analysis.

## HARDWARE DESCRIPTIONS

The Biotechnology System Biochemistry of Three Dimensional Tissue Engineering (BTS-BIO3D) is designed to conduct microgravity-based cell culture

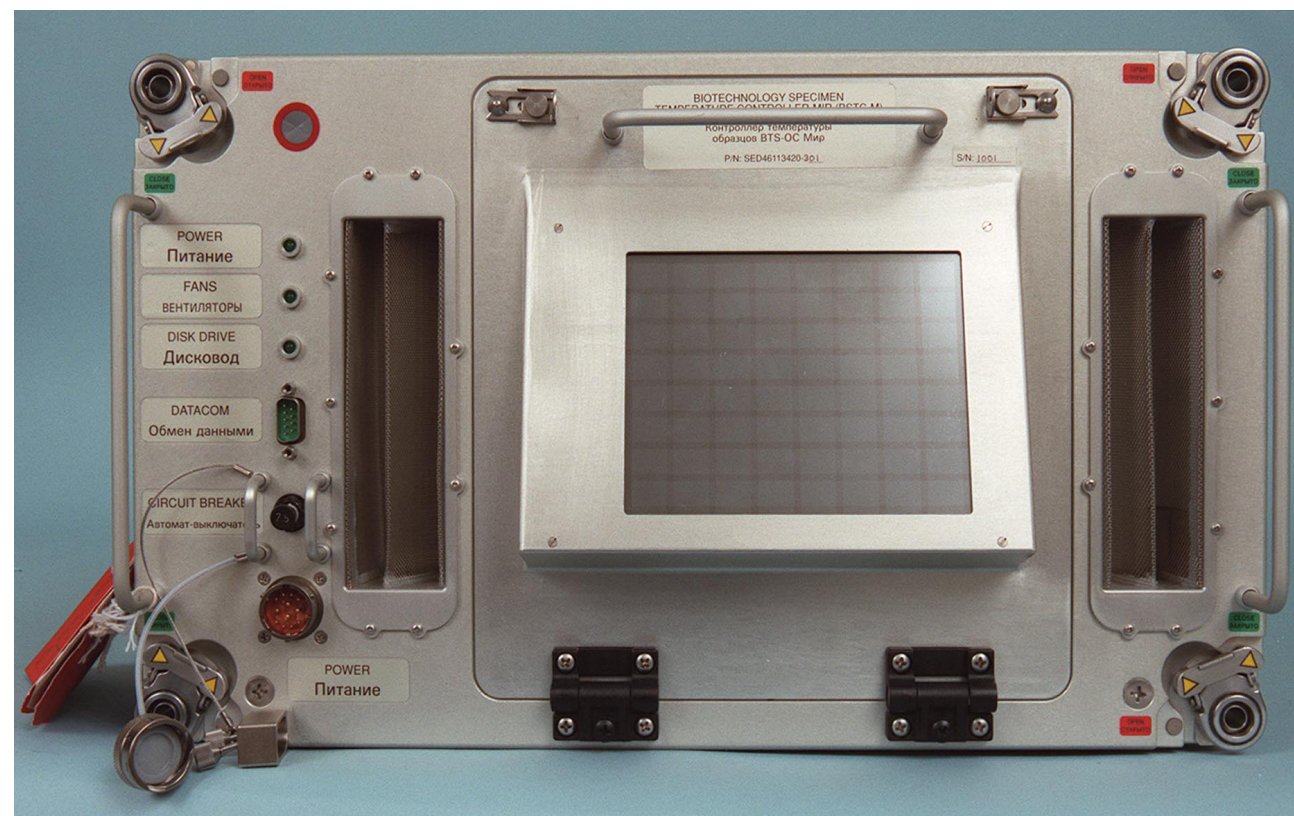

Figure MG-49 BSTC-M, Front Face

S97-05425

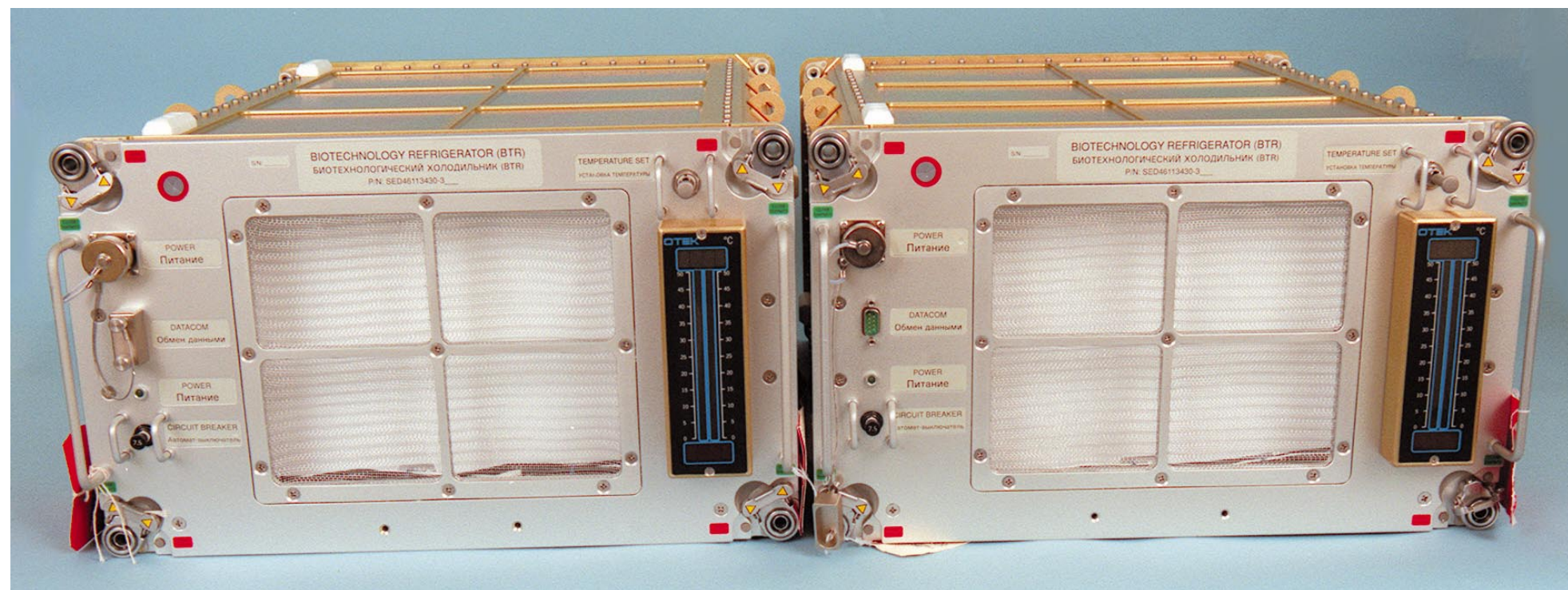

Figure MG-48 BTR-2 Units Shown, Only 1 Will be Flown

S97-05313

D.I.D.

BioTechnology Specimen Temperature Controller

D.I.D.

BioTechnology Refrigerator

**Principal Investigator:**  
Tom Goodwin  
NASA/JSC/SD4  
(281)483-7129

TABLE MG.5  
BIO3D HARDWARE

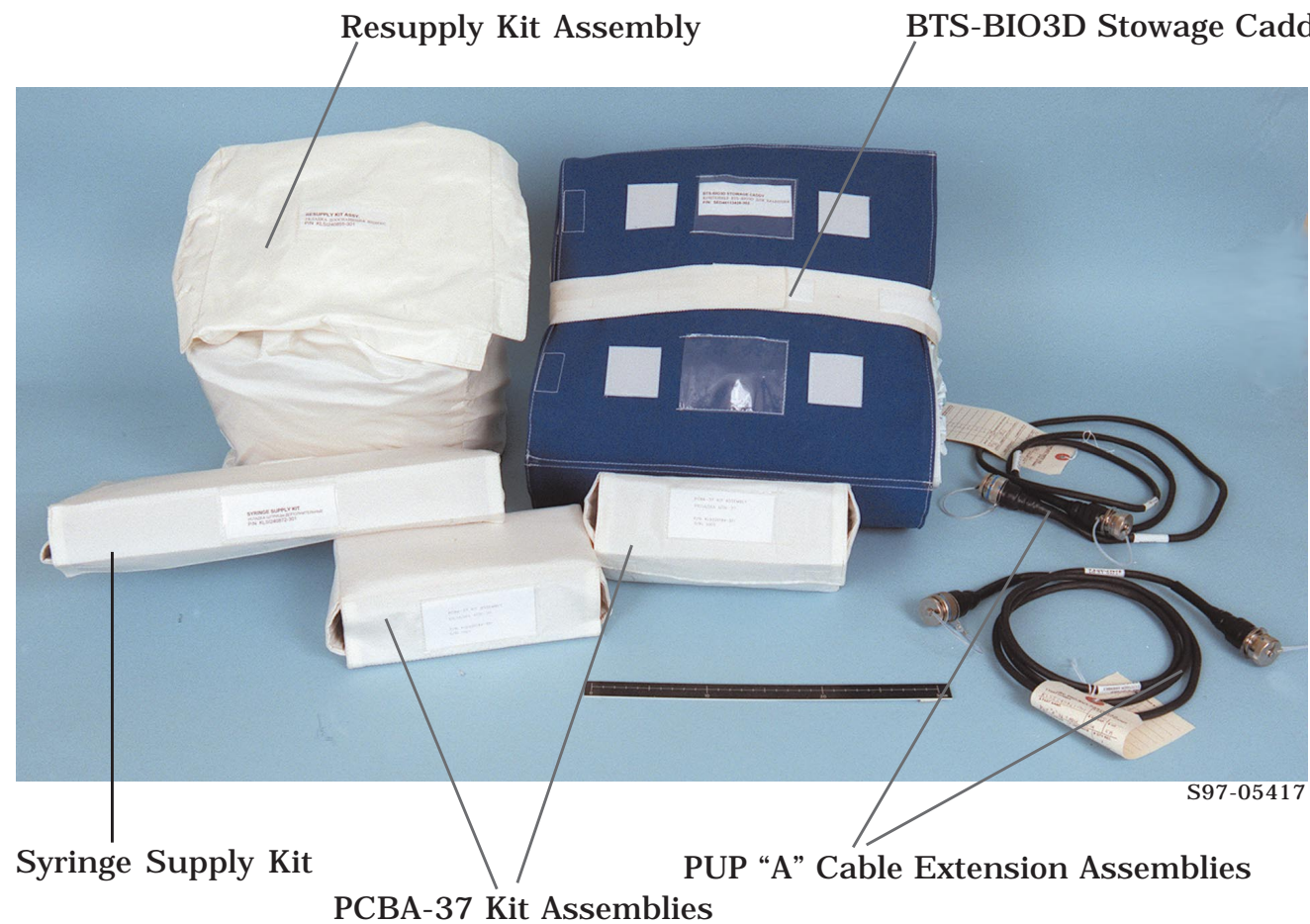

Figure MG-50 Experiment Supplies

Name	Part Number	Qty.	Units Developed
1. BioTechnology Experiment Module (BEM)/BioTechnology Specimen Temperature Controller-Mir (BSTC-M)	SED46113420-301	1	FA-1/CA, FA-2
- Single Stowage Locker Assembly	KLSI240946-301	1	FA-1/CA, FA-2
- BSTC-M Functional Unit	KLSI240689-301	1	FA-1/CA, FA-2
- Tissue Culture Module Assembly*	KLSI240936-302	3	FA-1, FA-2
	KLSI240936-303	3	FA-1, FA-2
	KLSI240936-304	3	FA-1, FA-2
	KLSI240936-305	3	FA-1, FA-2
2. BioTechnology Refrigerator (BTR) Single Stowage Locker Assembly	SED46113430-302	1	FA-1, FA-2/CA, FA-3
- BTR Functional Unit	KLSI240946-301	1	FA-1, FA-2/CA, FA-3
- Tissue Culture Module Assembly*	KLSI240691-301	1	FA-1, FA-2/CA, FA-3
	KLSI240936-301	6	FA-1, FA-2
	KLSI240936-302	12	FA-1, FA-2
	KLSI240936-303	12	FA-1, FA-2
	KLSI240936-304	6	FA-1, FA-2
	KLSI240936-305	6	FA-1, FA-2
	KLSI240936-306	6	FA-1, FA-2
- 7 x 8 in. Bitran Bags*	4743-S	16	FA-1, FA-2
- PCBA G3+ Cartridge Kit Assembly (36 total)*	SED46113424-301	1	FA-1
- PCBA G+ Cartridge Kit Assembly (36 total)*	SED46113424-302	1	FA-1
- PCBA G3+/G+ Cartridge Kit Assembly (38 total)*	SED46113424-303	1	FA-1
- DESI PAK*	N/A	8	FA-1
- Temperature Data Logger*	SED46107303-305	4	FA-1
3. Resupply Kit Assembly	KLSI240855-301	1	FA-1
- Fixative Syringe Kit (8 total)	KLSI240844-302	6	FA-1
- Transfer Syringe Pallet Assembly (20 total)	KLSI240851-301	1	FA-1
4. BTS-BIO3D Stowage Caddy	SED46113428-302	1	FA-1
- PUP, "A" J6 Cable Extension Assembly	KLSI240860-701	1	FA-1, FA-2, FA-3
- PUP, "A" J2 Cable Extension Assembly	KLSI240861-701	1	FA-1, FA-2, FA-3
- BTS/Null Modem Cable (planned for Shuttle use only)	SED46112608-302	1	FA-1
- Red Cap Dispenser (40 total)	KLSI240847-301	1	FA-1
- Glove Kit Assembly (50 pairs)	KLSI220186-303	1	FA-1
- Moll Zell Alcohol Wipe Dispenser Assembly (160 total)	KLSI240849-301	1	FA-1
- Benzalkonium Chloride Wipe Dispenser Assy (200 total)	KLSI240848-301	1	FA-1
- 16 x 16 in. Bitran Bags	4746-S	30	FA-1
- 7 x 8 in. Bitran Bags	4743-S	4	FA-1
- Marker	KLSI240842-301	2	FA-1
- BTR Desiccant Kit (4 packs)	KLSI240841-701	8	FA-1
- Fixative Syringe Kit (8 total)	KLSI240844-302	1	FA-1
- Transfer Syringe Pallet Assembly (20 total)	KLSI240851-301	1	FA-1
- Media Sample Syringe Pallet Assembly (26 total)	KLSI240850-301	1	FA-1
- Assay Mats	75-1750-08	10	FA-1
- Mask Kit Assembly (50 total)	KLSI220185-301	1	FA-1
- White Cannula Kit (26 total)	KLSI240843-701	1	FA-1
- BTS-BIO3D Logbook Science Data (#1)	KLSI240931-301	1	FA-1
- BTS-BIO3D Logbook Engineering Data (#2)	KLSI241076-301	1	FA-1
- BSTC-M Access Tool Assembly (Screwdriver)	KLSI240853-701	1	FA-1
- BSTC-M Filter Assembly (1 Filter)	KLSI240852-301	2	FA-1
- Microscope Operation Assembly	KLSI241198	3	FA-1
5. Syringe Supply Kit	KLSI240872-301	1	FA-1
- Transfer Syringe Pallet Assembly (20 total)	KLSI240851-301	1	FA-1
- Media Sample Syringe Pallet Assembly (26 total)	KLSI240850-301	1	FA-1
- White Cannula Kit (26 total)	KLSI240843-701	1	FA-1
6. PCBA-37 Kit Assembly (Note 3)	KLSI220184-301	2	FA-1
- PCBA-37 Assembly	KLSI220032-301	1	FA-1
- Electronic Simulator	KLSI220036-301	2	FA-1
- 9 Volt Battery	N/A	6	FA-1
7. PUP "A" J6 Cable Extension Assembly	KLSI240860-701	1	FA-1, FA-2, FA-3
8. PUP "A" J2 Cable Extension Assembly	KLSI240861-701	1	FA-1, FA-2, FA-3

Notes: CA Certification Article  
FA-1 Flight Article 1  
FA-2 Flight Article 2  
FA-3 Flight Article 3

- \* 1. Acceptance testing for these units will be performed at the Kennedy Space Center during prelaunch activities according to Section 8.0 of USA-MG-BTS-BIO3D/96-103.
- 2. All hardware listed in Table MG.4 will be submitted for Acceptance Testing.
- 3. The PCBA-37 Kit Assembly is a reflow item. Its proper operation is ensured by replacement of batteries and routine checks including the Acceptance Test.

**SYRINGE SUPPLY KIT**

P/N: KLSI240872-301  
Qty.: 1  
Mass: 1.2 kg  
Power: 0  
x,y,z: 25.4 x 7.5 x 38.1 cm

**PCBA-37 KIT ASSEMBLY**

P/N: KLSI220184-301  
Qty.: 2  
Mass: 0.565 kg  
Power: 0  
x,y,z: 24.89 x 24.89 x 28.45 cm

**PUP "A" J2 CABLE EXTENSION ASSEMBLY**

P/N: KLSI240861-701  
Qty.: 1  
Mass: 0.36 kg  
Power: 0  
x,y,z: 200.4 x 7.2 x 0 cm

**PUP "A" J6 CABLE EXTENSION ASSEMBLY**

P/N: KLSI240860-701  
Qty.: 1  
Mass: 0.36 kg  
Power: 0  
x,y,z: 200.0 x 7.2 x 0 cm



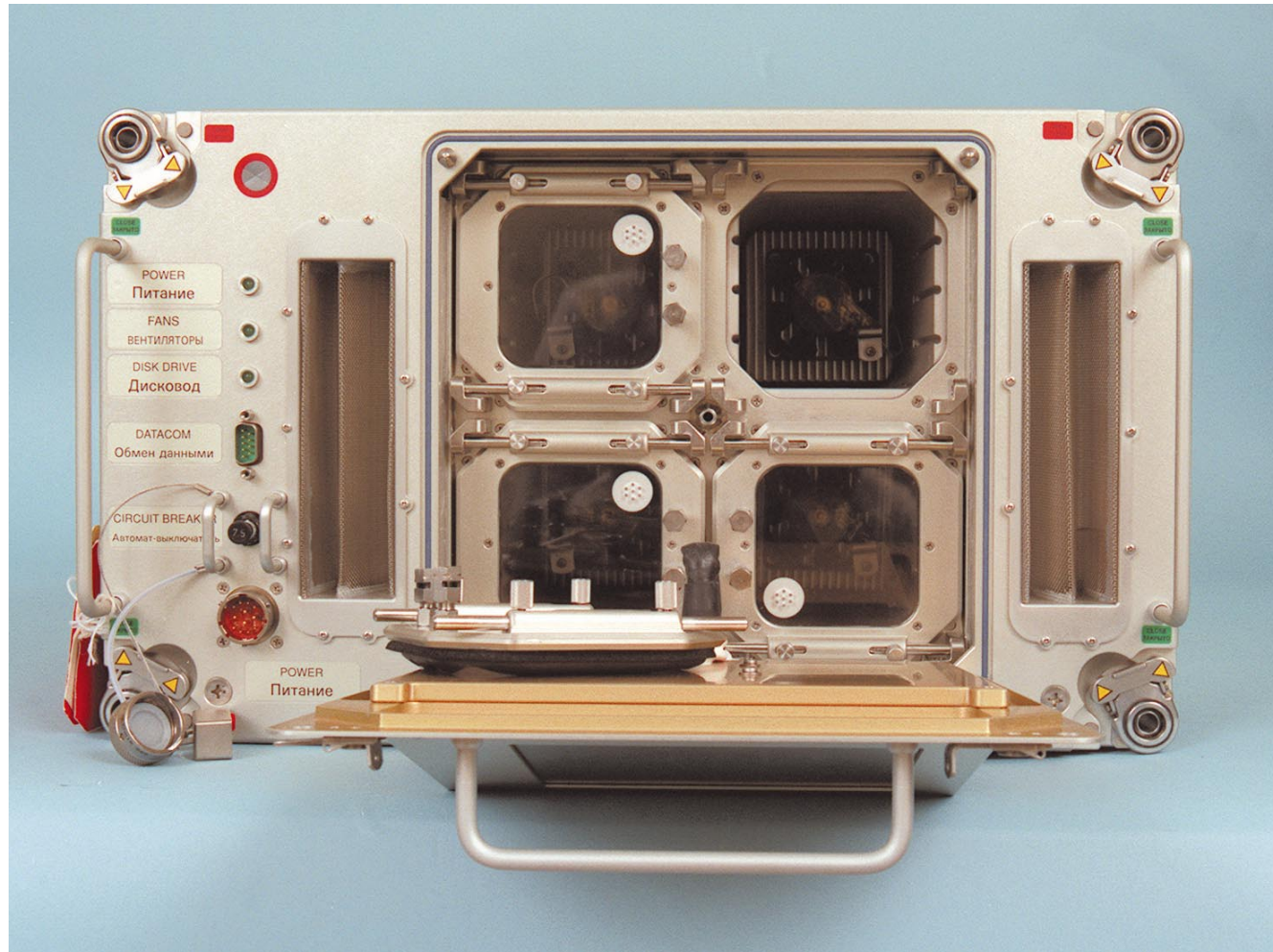

Figure MG-51 BSTC-M with Front Panel Door Down and One Incubation Chamber Door Removed S97-05311



Figure MG-52 BSTC-M Top View S97-05423

### BSTC-M

The BioTechnology Specimen Temperature Controller-Mir (BSTC-M) is a reconfigurable, multi-chamber temperature-controlled, static tissue culture apparatus. The BSTC-M is a single chassis divided into two sections. The first section contains the control computer, power supplies, signal conditioners and interface electronics. The second section contains the insulated incubation or refrigeration modules. These modules are individually computer controlled for temperature and time. Each module can hold up to three 30 mL tissue culture bags containing media and cells. These bags have two ports for sampling and fixing or inoculating.

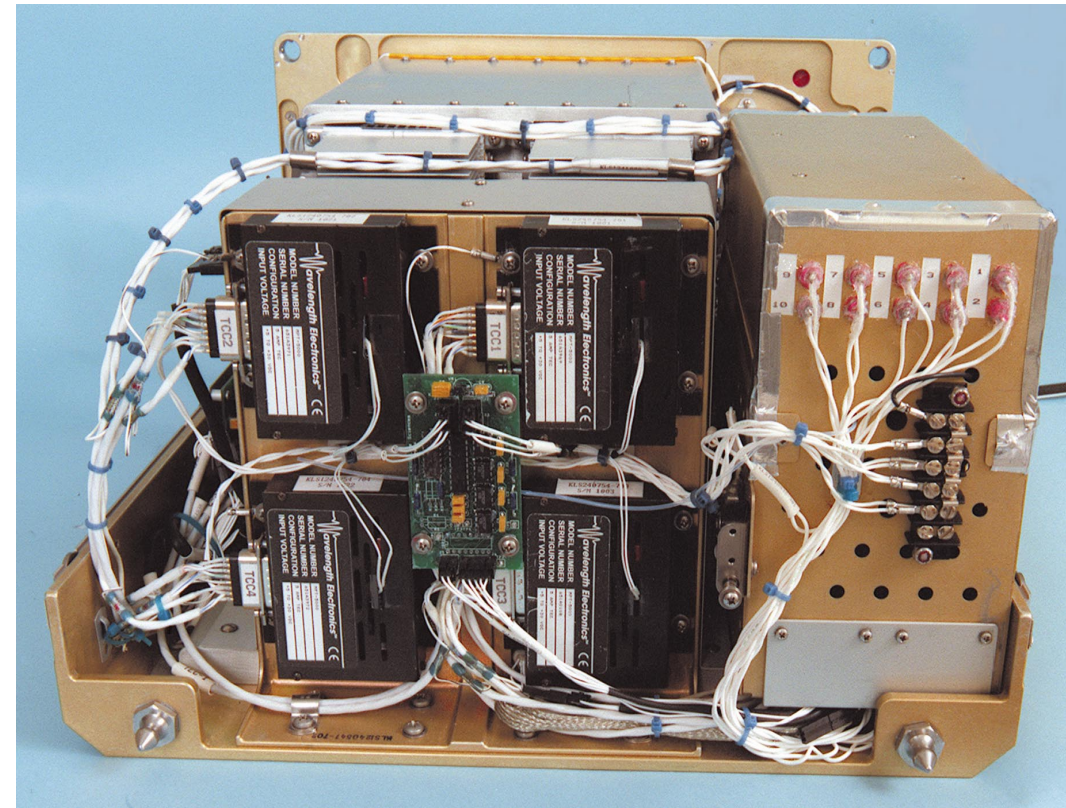

Figure MG-53 BSTC-M Rear View

S97-05419

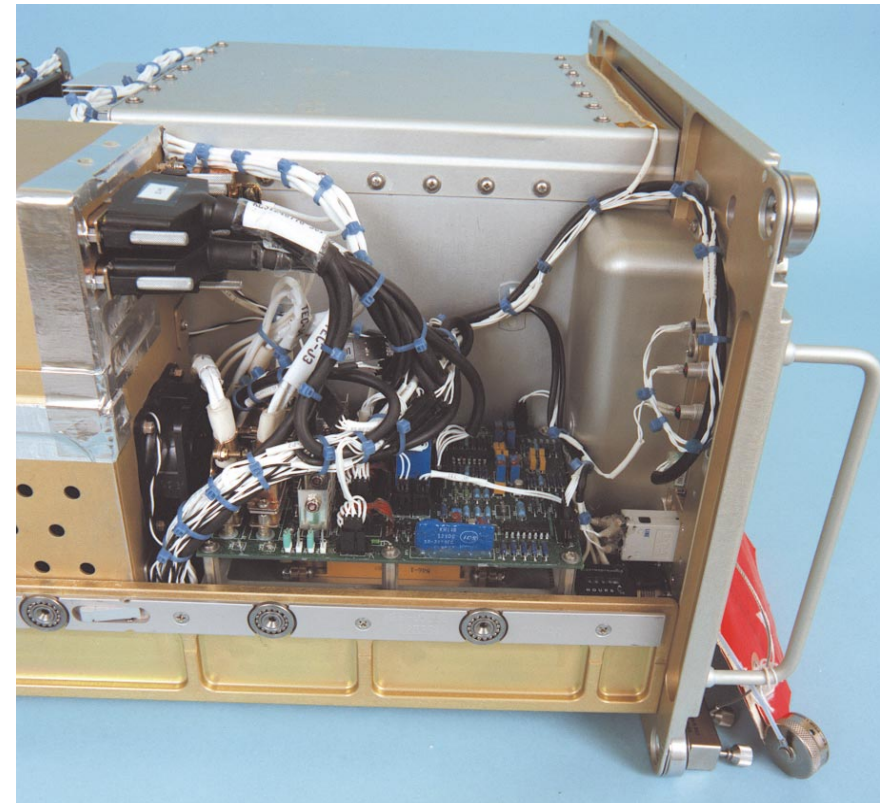
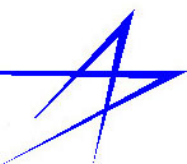

Figure MG-54 BSTC-M Left Side View

S97-05421

### BIOTECHNOLOGY SPECIMEN TEMPERATURE CONTROLLER-MIR (BSTC-M)

P/N: SED46113420-301  
 Qty: 1  
 Mass: 9.17 kg  
 Power: 122 W  
 Start-Up Current: at 27V:  
 47.8 amps/  
 33microseconds  
 Onboard Elect.  
 Supply: DC Source: 23-32 V  
 Insulation  
 Resistance:>20 MOhm  
 x,y,z: 58.29 x 47.07 x 28.43 cm  
 Loc.: PR, SIC3-I-1





S97-05758

Figure MG-55 BSTC-M with Tissue Culture Modules Inside

## BSTC-M COMPONENTS

### Control Computer

#### CPU Card:

The control computer contains an AT-compatible CPU card running a 486 (P = Microprocessor = mP at a clock speed of 50 MHz). Some of the features of this card include: a watchdog timer that resets the system if the program stops running; built-in calendar and clock with an external battery to power the clock during power down; and three solid-state disks, one containing the BIOS and DOS in ROM. A flash programmer is built into this disk for remote reprogramming through a serial port. The third is multifunctional. It accepts EPROM SRAM or flash memory and can be used to store data, conversion tables, or other operating systems.

This system also has the ability to communicate using RS-232, RS-485 and RS-422.

#### Data Acquisition (DAC) Card:

An octal DAC card is installed to communicate with the Thermoelectric Cooler Module (TEC) controllers. This card contains 8 12-bit digital-to-analog converter channels that can be programmed for  $\pm 5$ , 0-5, and 0-10V output. For this application it will be programmed to output 0-5V.

#### SCSI-2 Card:

This card is used to interface with an embedded 341 MB hard disk drive.



Figure MG-56 Tissue Culture Module Kits



S97-05765

Figure MG-57 Contents of a Tissue Culture Module Kit

S97-05768

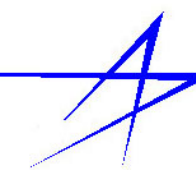

### SVGA Video Card:

This card supports the 6.4 inch diagonal flat panel display.

### Analog I/O Card:

This card contains 16 single-ended or 8 differential input channels with programmable gains of 1, 10, and 100. It also contains 19 digital Input/Output (I/O) lines and 3 16-bit counter/timers. This board is installed to provide the Principal Investigator with control and data collection capability beyond temperature and time.

### Card Cage:

The control computer and interface cards will be housed in a card cage containing an 8-slot passive backplane.

### Incubation/Refrigeration Chambers

The Incubation/Refrigeration Chambers are individually temperature and time controlled experiment volumes. The temperatures can be controlled between 4 and 50 °C in 1 °C steps. The heating and cooling system for each chamber is a TEC controlled by a bi-polar TEC controller. The control computer uses one of its DAC channels to communicate to the controller which temperature to maintain. The controller uses a thermistor for feedback to maintain the selected temperature.

### Cooling Fans:

There are 4 cooling fans for the Incubation/Refrigeration Chambers, one for each Incubation Chamber. Each of the fans are connected to a Fan Speed Controller (FSC). The FSC senses the temperature of the heatsinks attached to the TEC. As the temperature of the heatsink rises above 35 °C, the FSC increases the drive current to the fan allowing it to move more air.

The BSTC-M Electronics Chamber is cooled via a fan mounted to the external surface of the perforated card cage housing.

The FSC will continue to deliver more current until it is fully on, which happens at approximately 45 °C. At any temperature below 35 °C the fan is at idle speed which is approximately 50% of full speed.

### Fan Speed Monitoring:

The fan speed is monitored by using frequency to voltage converters. The rotation hub of the fan has a white spot painted onto its surface. Facing this spot is an optical reflective switch. As the fan rotates the spot passes in front of the switch causing it to turn on momentarily. This pulse is detected by the signal conditioner and counted.

### Current Monitoring:

The current supplied to each TEC is monitored by a small, low cost, current shunt designed to measure currents of DC, AC, or the combination of both in a conductor.

### Hard Disk Drive

The computer will store data on an internal Hard Disk Drive (HDD). The HDD is a 2.5 inch, 311 MB unit with a SCSI interface. The HDD will be partitioned as two disks and the data will be stored in both locations. This is to help ensure the integrity of the data.

### Pressure Sensor

The pressure sensor is present to monitor the spacecraft barometric pressure. Hard disk drives rely on air to act as a bearing and the heads "float" on this curtain of air. If the pressure drops, there is less air available to act as a cushion. If the pressure drops below 10 psi there is not enough air for the HDD to operate reliably. The computer is programmed so that if the pressure drops below 11 psi the HDD is turned off and the heads are parked over the landing zone and it remains in this condition until the pressure is again over 11 psi.

### General

#### Flat Panel Display:

The BSTC-M is fitted with a 6.4-inch diagonal flat panel display. The panel allows the operator to view all of the system parameters in either numerical or graphical output. This panel is also instrumental in changing the various experiment protocols.

### Transparent Touch Screen:

In front of the flat panel display is a transparent touch screen. This is the user interface with the BSTC-M used for changing experiment protocols and commanding the system for data displays.

### RS-232:

The front panel contains an RS-232 port for communication with external computers (used in contingency situations).

### Circuit Breaker:

The front panel contains a resettable circuit breaker as a safety precaution for short circuits. It also doubles as a power switch.

### Power

#### Connector:

The Power Connector is the power interface for the unit. It receives 28V DC from an external power source.

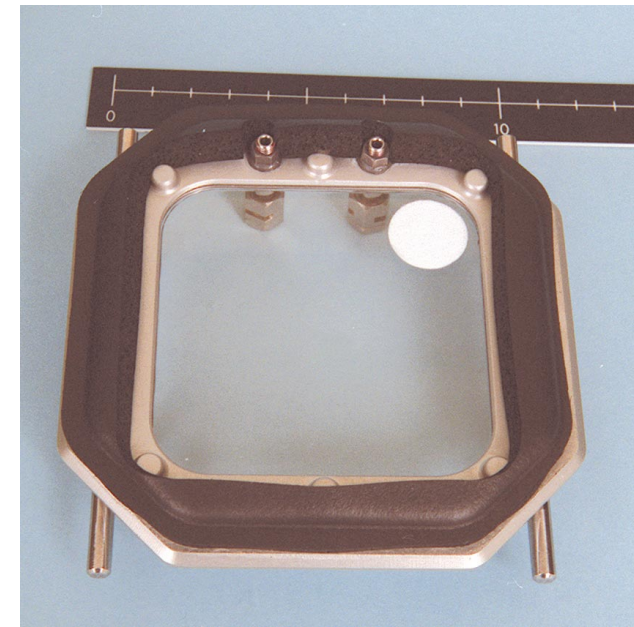

S97-05309

Figure MG-58 Incubation Chamber Door, Showing Inner Seal

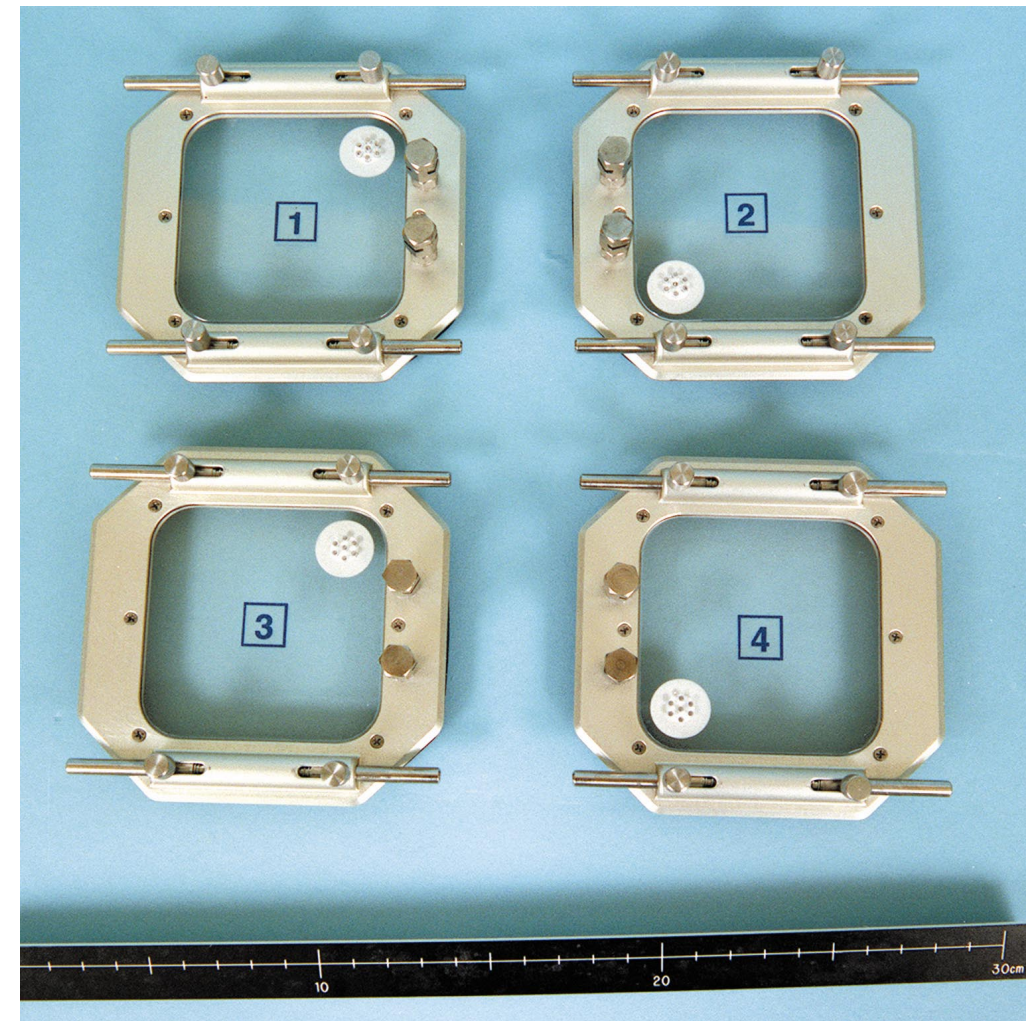

S97-05757

Figure MG-59 Incubation Chamber Doors Removed From BSTC-M Front Panel



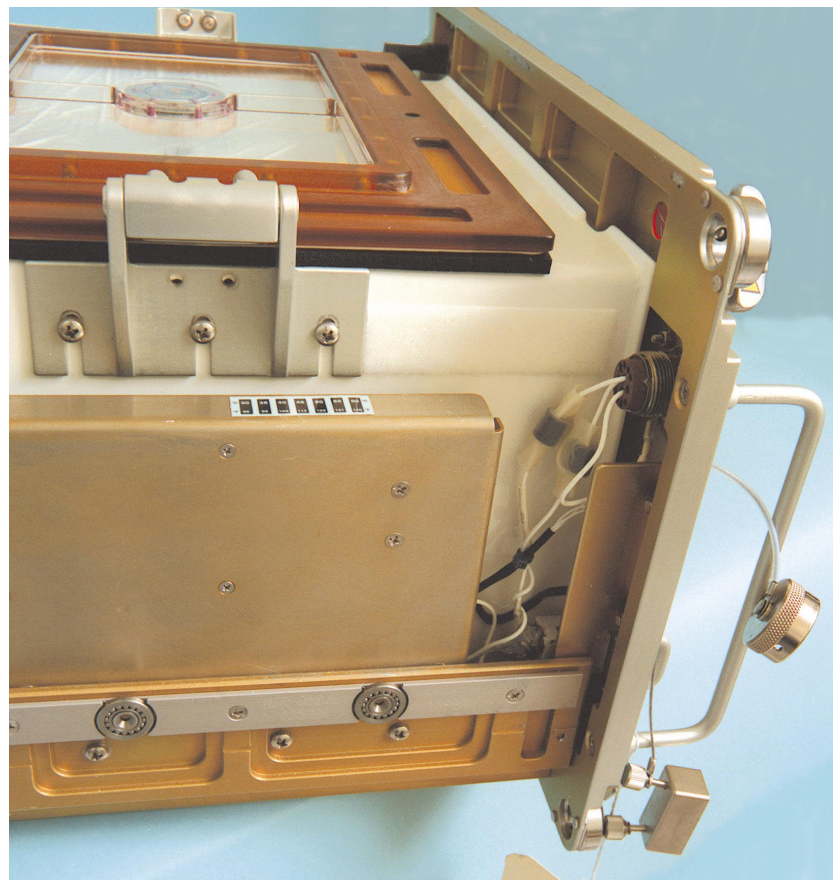

Figure MG-60 BTR, Left Side View

S97-05319



Figure MG-61 BTR, Rear View

S97-05315

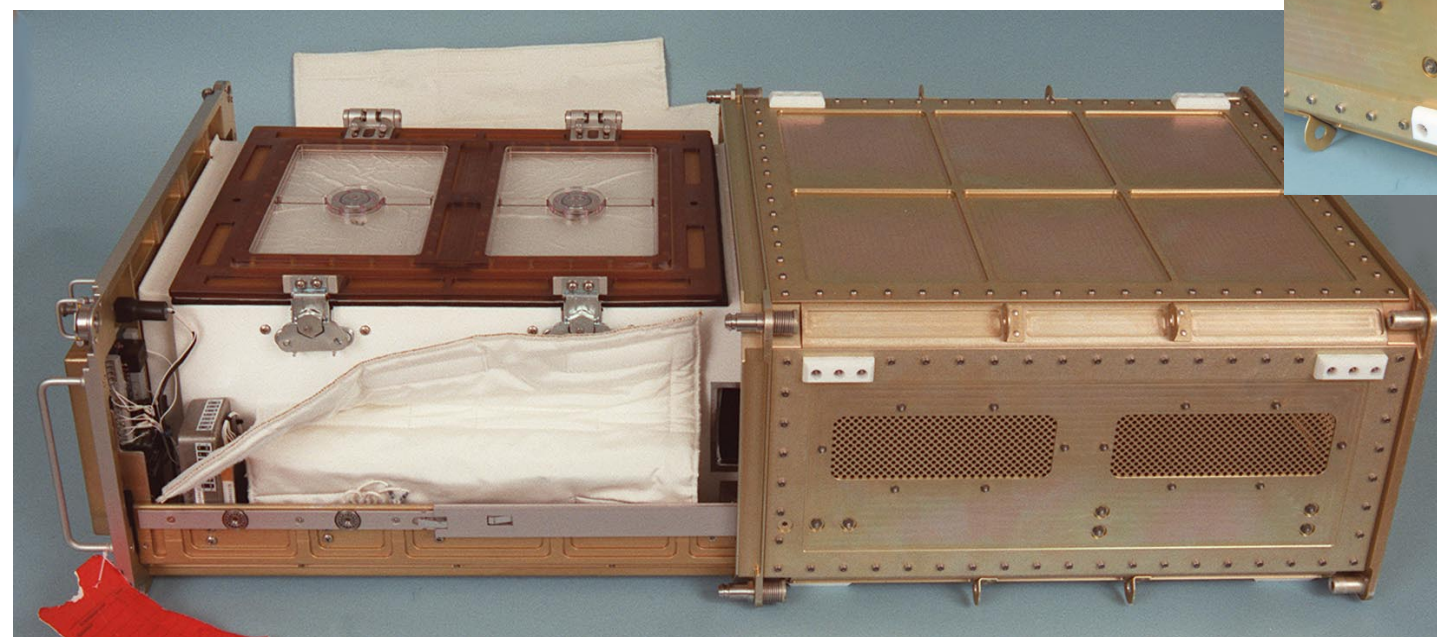

Figure MG-63 BTR Extended out of Locker

S97-05324

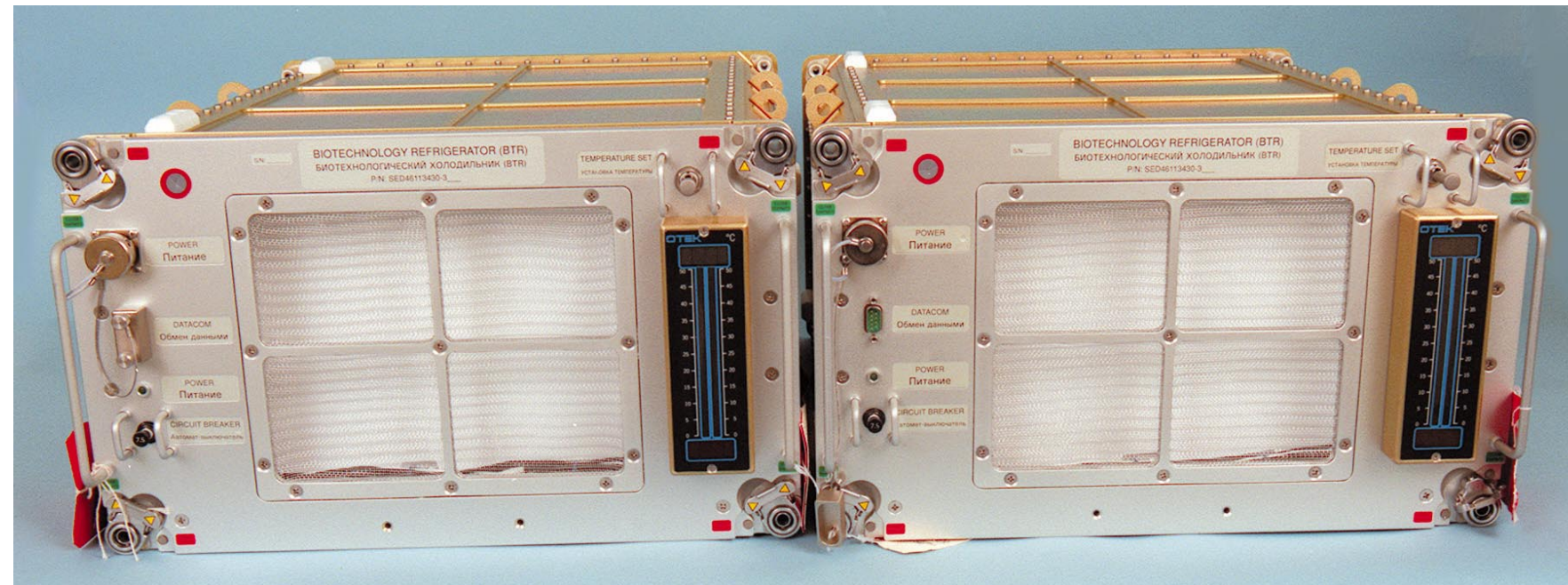

Figure MG-62 BTR Front Panel (only 1 will be flown)

S97-05313



Figure MG-64 BTR, Left Side View, Rearward

S97-05318

**BIOTECHNOLOGY REFRIGERATOR (BTR)**

P/N: SED46113430-302  
 Qty: 1  
 Power: 177 W  
 Mass: 25.66 kg (w/o contents)  
 x,y,z: 58.3 x 47.1 x 28.5 cm  
 Start-up Power at 27V: 36.6 amps/ 2.5 milliseconds  
 Insulation Resistance: >20 Megaohms



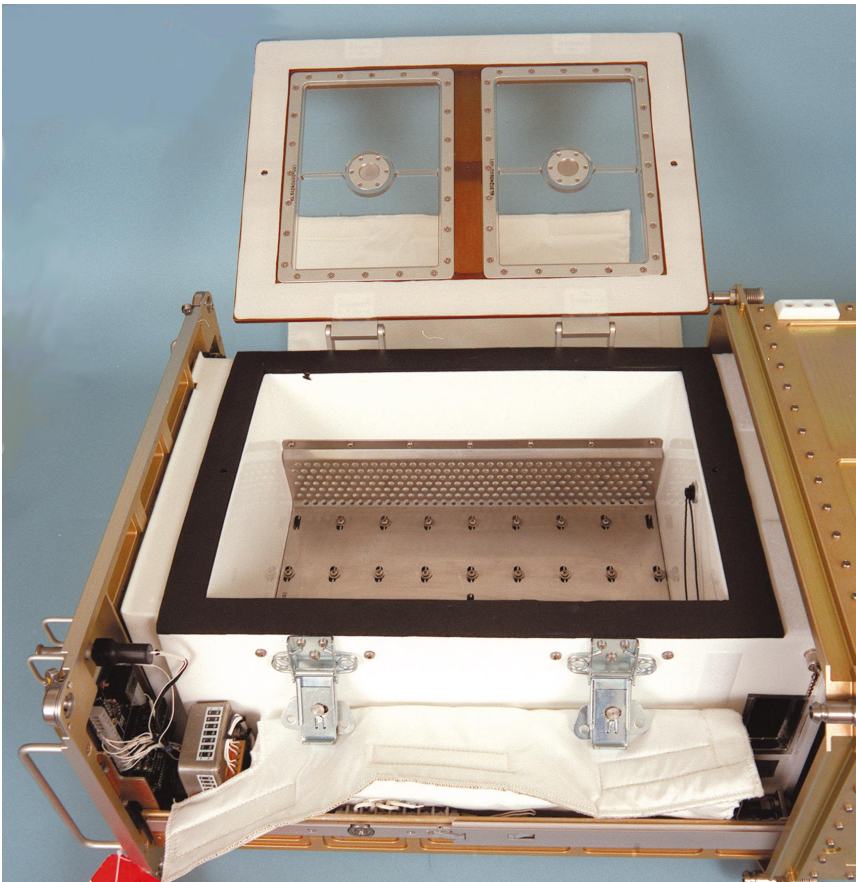

Figure MG-65 BTR Cooling Chamber with Access Door Open



Figure MG-66 BTR, Right Side View

S97-05321

## BIOTECHNOLOGY REFRIGERATOR (BTR)

### Temperature Controller

A commercially available controller for Thermoelectric Cooler (TEC) Modules is used. These units use thermistors to feedback temperature information for use by their on-board PID controllers. There will be two of these units on board the BTR setup in a master/slave configuration. These units are basically configured in series with the TEC modules and control the amount of current delivered to the TECs. The farther away the actual temperature is from the setpoint the more current the controller supplies to the TEC. The setpoint can be set by using a potentiometer built into the unit or by supplying a voltage between 0 and 5V DC to its modulation input pins. In the case of the BTR, the modulation input voltage will come from the Single-Loop Process Controller located on the front panel of the BTR.

S97-05323

### Single-Loop Process Controller

The Single-Loop Process Controller functions as the temperature and setpoint display as well as the controller for many of the BTR functions. The unit contains two 51-segment bar graph displays, two 4-digit Light Emitting Diode (LED) numeric displays, inputs for an interlock switch, an optically isolated RS-232 port, a 0 to 5V DC DAC output, a 10A relay, and inputs for a setpoint switch. The DAC output of this unit supplies the modulation input voltage to the Temperature Controllers. The setpoint switch input sets the voltage output of the DAC.

The setpoint value is displayed on one of the numeric displays while the actual temperature is displayed on the other. A signal from the interlock switch causes the 10 A relay to open turning off power to the TEC controllers. Communications with a host computer is achieved through the optically isolated RS-232 port. The reset point can be set using a host computer (MIPS-2L) running the proper software. Data can also be logged to a host computer via the RS-232. This controller stores its setpoint data and program in nonvolatile Random Access Memory (RAM).

### Fan Speed Controllers

These units control the amount of current supplied to the cooling fans by

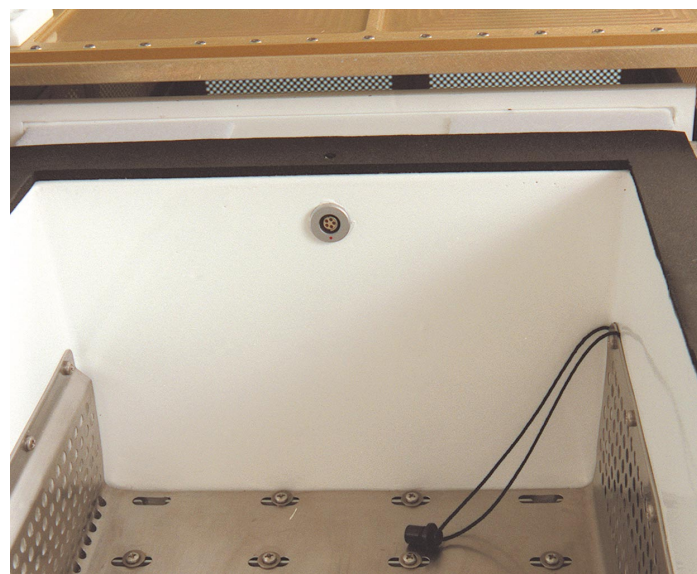

Figure MG-68 BTR Interior Connection

S97-05322



Figure MG-69 Access Latch for Cooling Chamber Door

S97-05317

monitoring the temperature of the air entering the BTR. Under normal conditions the fan will be running at about 50% of its rated voltage. If the air temperature rises above a specific preset value, the current to the fan will increase proportionally until the fan is running at full speed. The full speed condition will occur when the ambient temperature reaches approximately 40 °C.

### Setpoint Switch

This is a momentary three-position locking-lever toggle switch with the center position being the lock. To increase the setpoint value, lift the lever and hold. The setpoint display will start to increment in 1 degree steps once each second. Releasing the lever returns it to the locking position. To decrease the setpoint, push the lever down.

### Interlock Switch

This switch causes the power to the TEC modules to be turned off when the BTR drawer is opened. Closing the drawer causes the power to be reapplied to the TEC modules. \*

## BIOTECHNOLOGY REFRIGERATOR (BTR)

P/N: SED46113430-301  
 Qty.: 0  
 Mass: 31.3 kg  
 Power: 135 W  
 x,y,z: 58.42 x 46.04 x 27.32 cm





**BTS-BIO3D STOWAGE CADDY**



S97-05398

Figure MG-71 BTS-BIO3D Stowage Caddy Contents

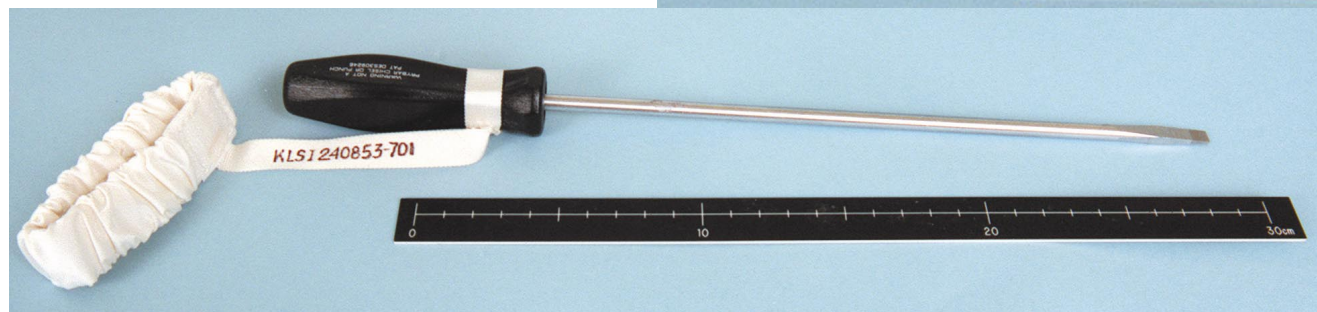

S97-05406

Figure MG-70 BSTC-M Access Tool Assembly

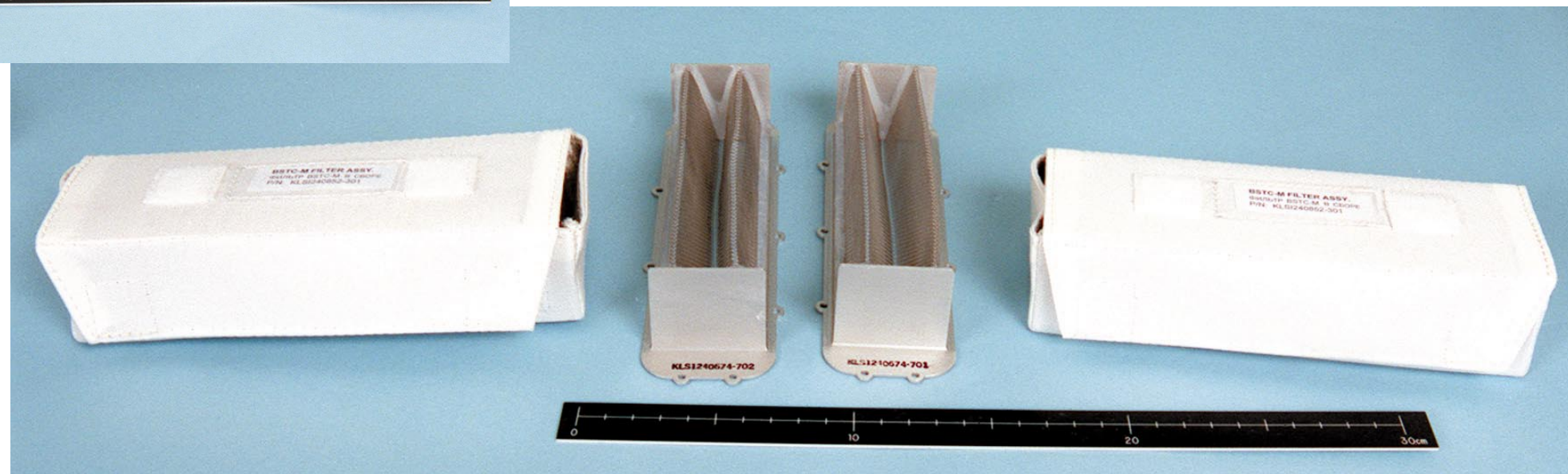

S97-05405

Figure MG-72 BSTC-M Filter Assembly (Air Inlet Filter)

**BTS-BIO3D STOWAGE CADDY**

P/N: SED46113428-302  
 Qty.: 1  
 Mass: 6.78 kg  
 Power: 0  
 x,y,z: 35.56 x 40.64 x 20.32 cm  
 Loc.: N/A

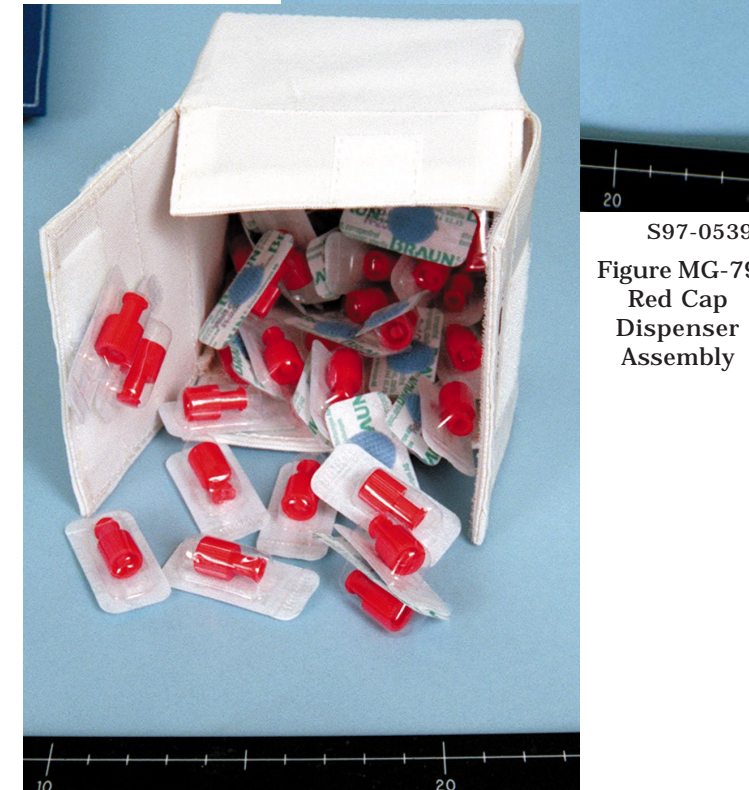

S97-05389  
Figure MG-75  
Benzalkonium Chloride  
Wipes Dispenser  
Assembly

Figure MG-76 Benzalkonium Chloride Wipes

S97-05393  
Figure MG-79  
Red Cap  
Dispenser  
Assembly

Figure MG-78 Red Caps

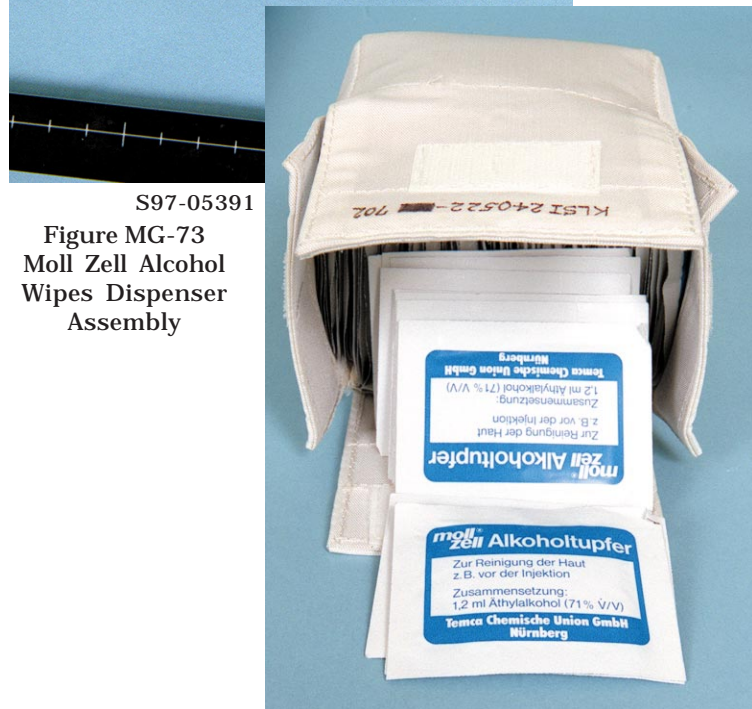

Figure MG-74 Moll Zell Alcohol Wipes  
(Ethanol Wipes)

Figure MG-77 Mask Kit Assembly

S97-05391

Figure MG-73  
Moll Zell Alcohol  
Wipes Dispenser  
Assembly

S97-05388

S97-05390

S97-05392

S97-05394



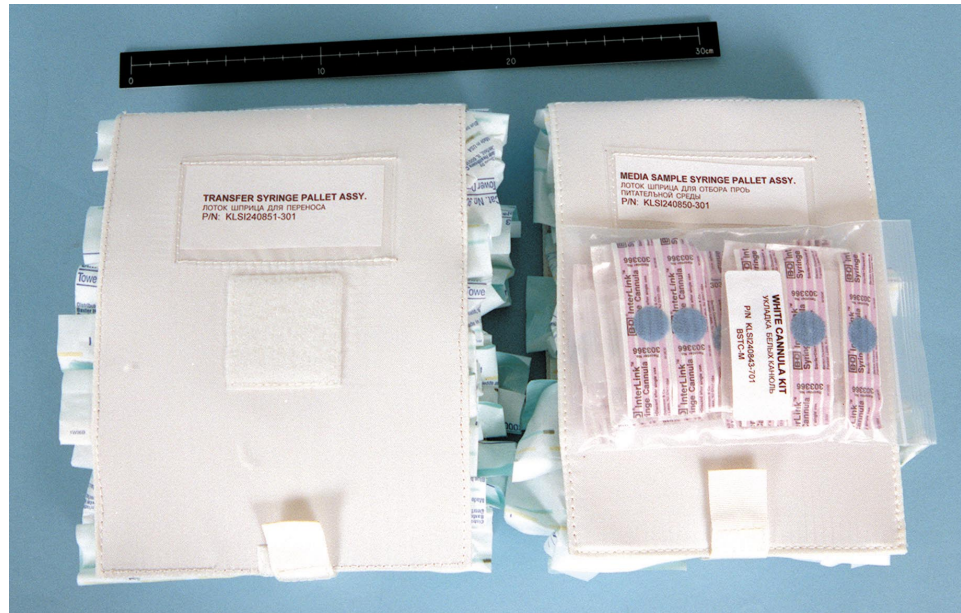

S97-05412

Figure MG-80 White Cannula Kit and Contents of the Transfer and Media Sample Syringe Pallets



S97-05281

Figure MG-82 Bitran Bags



S97-05400

Figure MG-83 Assay Mats



S97-05411

Figure MG-81 Transfer and Media Sample Syringe Pallets, and White Cannula Kit

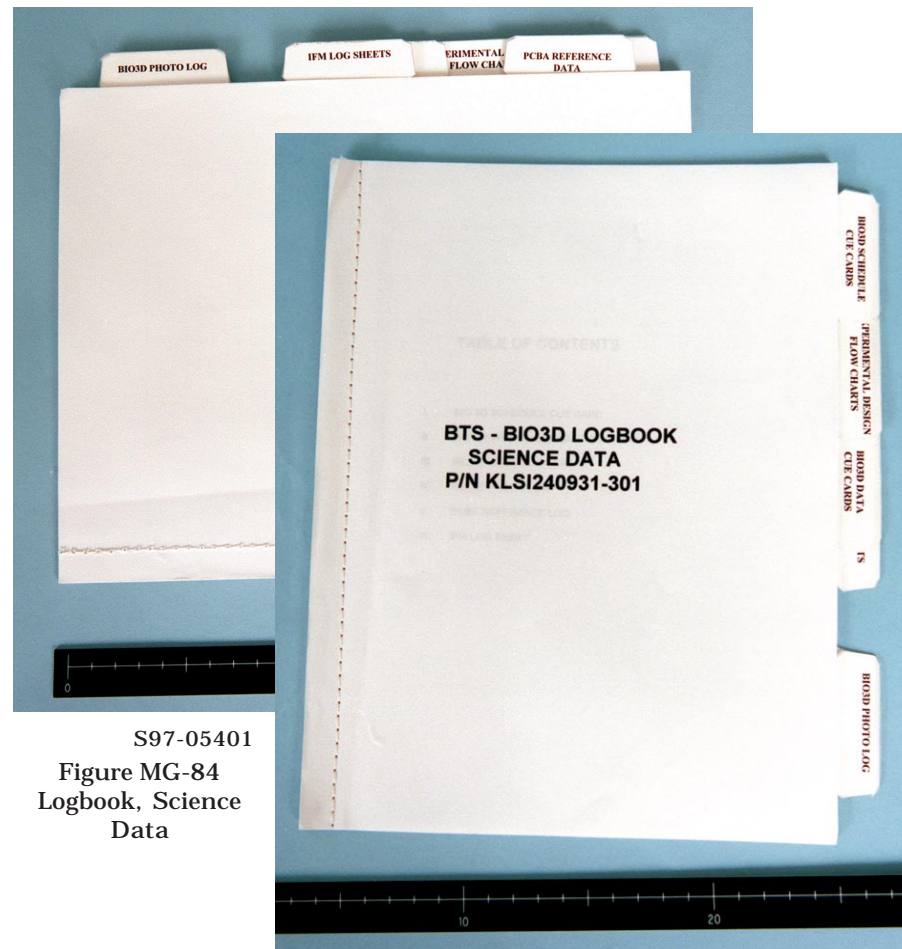

S97-05401  
Figure MG-84  
Logbook, Science  
Data

Figure MG-85 Logbook, Science Data, Rear

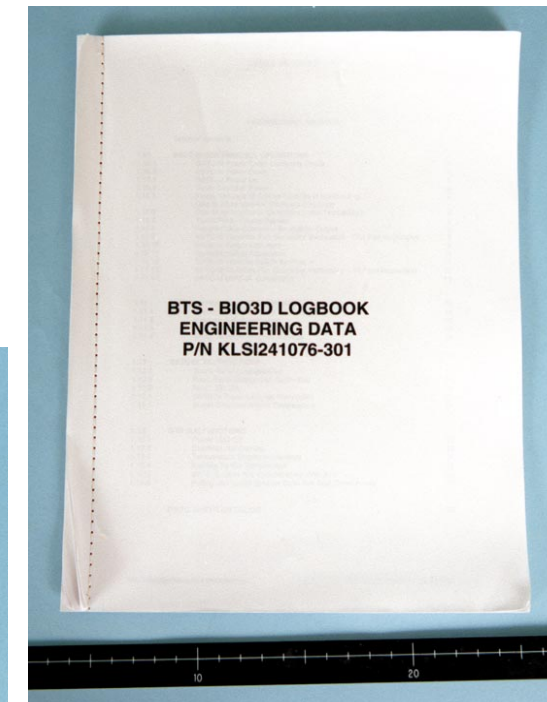

S97-05403

Figure MG-86 Logbook, Engineering Data

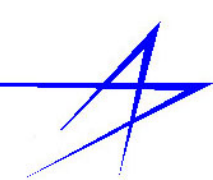

**RESUPPLY KIT ASSEMBLY**



Figure MG-87 Sterile Gauze Pad and Fixative Syringe

S97-05408

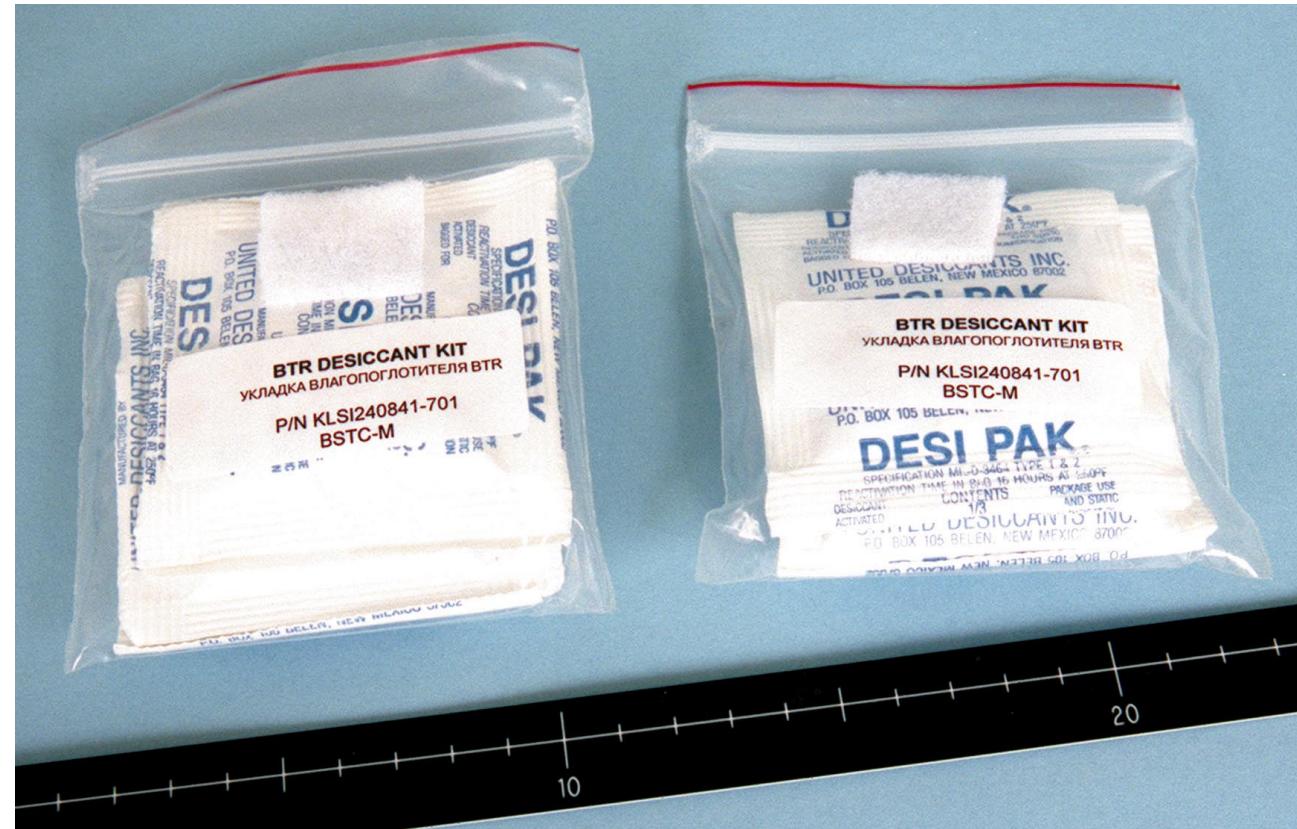

Figure MG-89 BTR Desiccant Kit

S97-05404



Figure MG-88 Resupply Kit Assembly Contents

S97-05409

**RESUPPLY KIT ASSEMBLY**

P/N: KLSI240855-301  
 Qty.: 1  
 Mass: 3.3 kg  
 Power: 0  
 x,y,z: 24.89 x 24.89 x 28.45 cm

# BTS COCULTURE (COCULT)

**Principal Investigator:**  
Tom Goodwin  
NASA/JSC/SD4  
(281)483-7129

**BTS-COCULT HARDWARE COMPONENTS**

The BTS-COCULT flight and back-up system deliverables are listed in Table MG.6.

**ENGINEERING DEVELOPMENT UNIT-MIR (EDU-M)**

**EDU-M HARDWARE DESCRIPTION**

The EDU-M houses a rotating-wall perfused vessel in a controlled atmosphere held at 36 ± 1°C with support system and electronics for data logging and postflight analysis of system performance. The bioreactor volume of 125 mL contains a fluid growth medium and is oxygenated, as needed, to support cell growth.

TABLE MG.6  
BTS-COCULT HARDWARE LIST

Name	Part Number	Qty
1. BioTechnology Experiment Module/Engineering Development Unit - Mir (BEM/EDU-M)	SED321054859-002	1
- Bioreactor Enclosure Assembly	SED46107304-304	1
- EDU-M Stowage Foam	528-33388-3	1
2. BioTechnology Refrigerator (BTR)	SED46113430-302	1
- Single Stowage Locker Assembly	KLSI240946-301	1
- BTR Functional Unit	KLSI240691-301	1
- Temperature Data Logger	SED46107303-305	4
- PCBA G3+ Cartridge Kit Assembly (30 total)*	KLSI241172-301	1
- PCBA 6+ Cartridge Kit Assembly (30 total)*	KLSI241172-302	1
- DesiPak	KLSI241087-311	1
- Antibiotic Bag (15 total)*	KLSI240517-301	2
- Lyophilized GTSF-2 Media (0.8 L)*	KLSI240516-303	7
3. Experiment Control Computer (ECC)	SED32104865-002	1
- Control Module Assembly	SED46107305-306	1
- Power Module Assembly	SED46107310-308	1
- ECC Foam Assembly	SED46112606-303	1
- Interface Power Cable	SED46107317-706	1
4. BTS/EDU Data Cable	SED46107308-303	1
5. Power Cable Assembly (ECC to BEM)	10108-10082-01	1
6. BTS-COCULT Resupply Kit #1	SED46113433-302	1
- Media Sample Syringe Pallet	KLSI241177-302	1
- Optical Correction Lens Assembly	KLSI241188-301	1
- Cell Collection Bag	KLSI241087-312	1
- Omnifix Syringe	KLSI241179-301	4
- Media Exchange Filters Assembly	KLSI241206-301	1
- Collection Bag Cap Kit	KLSI241087-303	1
- BTS-PC Card	KLSI241155-301	1
- BTS-PC Card	KLSI241155-302	1
- Red Luer Cap Kit	KLSI241087-316	1
- PCBA Battery Kit	KLSI241087-315	1
- Benzalkonium Chloride Wipe Dispenser	KLSI241089-304	2
- DesiPak	KLSI241087-311	2
- Blue Absorbent Pad Kit	KLSI241087-317	1
- ECC Power Adapter Cable	KLSI240720-701	1
- Air Vent Insert Assembly	KLSI240531-701	1
- Gauze Pad Kit	KLSI241087-309	1

TABLE MG.6  
BTS-COCULT HARDWARE LIST (CONCLUDED)

Name	Part Number	Qty
7. BTS-COCULT Stowage Caddy #2	SED46115086-304	1
- Media Sample Syringe Assembly	KLSI241177-301	1
- Red Luer Cap Kit	KLSI241087-316	2
- Blue Luer Cap Kit	KLSI241087-310	1
- Omnifix Cell Sample Fixative Syringe Pallet	KLSI241165-301	1
- Contingency Pallet	KLSI241228-301	1
- Glove Dispenser		1
- Benzalkonium (BZK) Chloride Wipe Dispenser	KLSI241081-302	2
- Septum Kit (10 total)	KLSI241089-303	1
- Curved Forceps	KLSI241087-314	1
- Straight Forceps	KLSI240651-301	1
- Mask Kit (65 total)	KLSI240651-302	1
- Squarehead Plug Kit (6 total plugs)	KLSI241087-302	1
- Internal Hex Driver	TM4B	1
- Flat Head Screwdriver	SDD440	1
- Blank Label Kit (25 total)	KLSI241087-306	1
- Velcro Kit (10 total)	KLSI241087-305	1
- Octaslide pH Indicator	3403	1
- Marker	KLSI240842-701	1
- Trash Caddy	KLSI241105-701	1
- Aluminum Foil Kit	KLSI241087-308	1
- BTS-COCULT PC-Card (PCMCIA Card)	KLSI241130-302	1
- BTS/Null Modem Cable	SED46112608-302	6
- Glove Bag Adapter Frame Assembly	KLSI241223-301	1
- Window Assembly	KLSI241224-301	1
- Window Removal Tool Assembly	KLSI241226-301	1
8. BTS-COCULT Resupply Kit #2	SED46113433-303	1
- BTS-COCULT Logbook	KLSI241200-301	1
- DesiPak	KLSI241087-311	3
- Glove Bag Assembly (with Attachment Ring)	KLSI241221-701	3
- Glove Bag Assembly (wo/Attachment Ring)	KLSI241222-701	1
- Glove Bag Assembly (wo/Attachment Ring)	SED46107322-703	1
- Gas Supply Hose	KLSI240516-302	1
- Lyophilized GTSF-2 Media (0.8L)	KLSI241087-316	2
- Red Luer Cap Kit	KLSI241227-301	1
- Data Capture Kit **		1
9. Water Bag Stowage Tray Assembly*	SED46112604-301	1

**NOTES:**

\* This hardware will be acceptance tested at the NASA Kennedy Space Center during the final prelaunch tests.

\*\* The Data Capture Kit supports the BTS Diagnostic Experiment

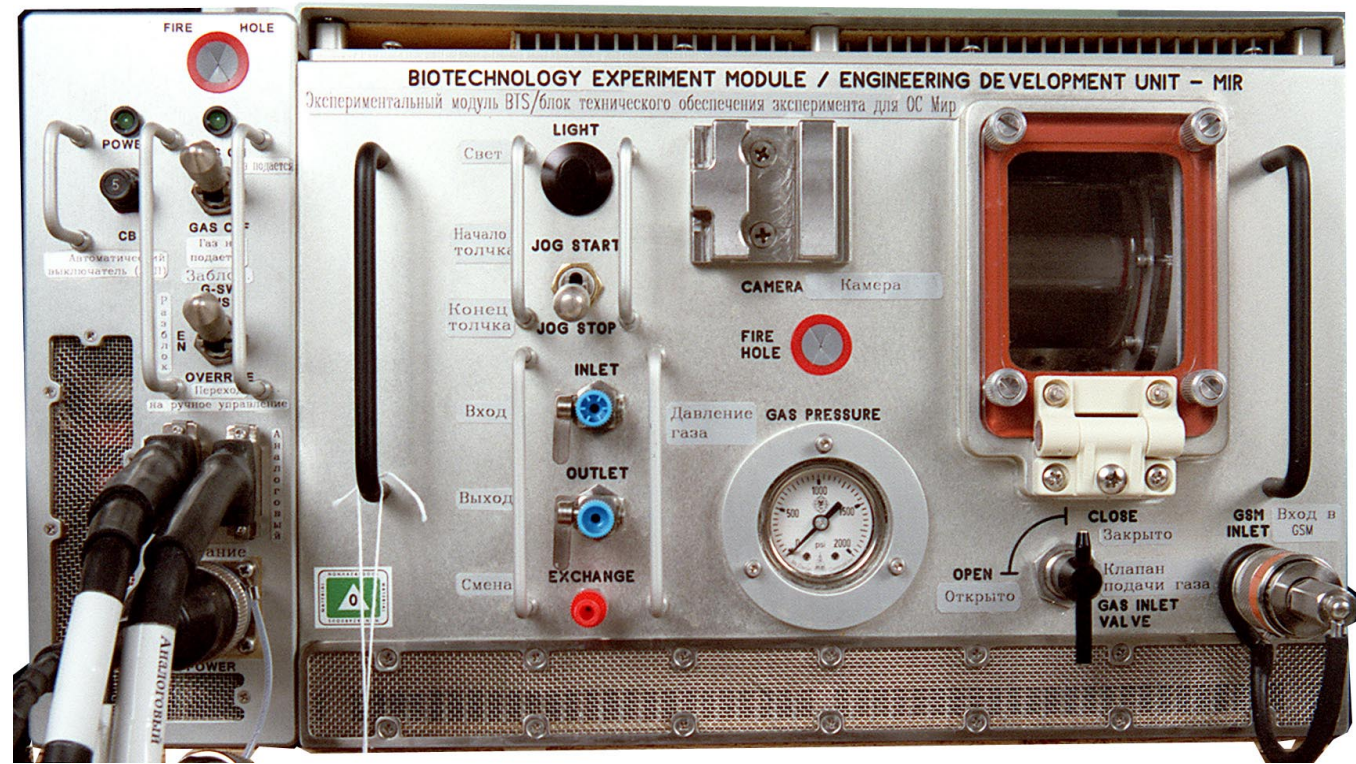

Figure MG-90 COCULT EDU-M Front Panel (Grey Tape Will Cover the Fire Holes on Orbit)

S97-06883

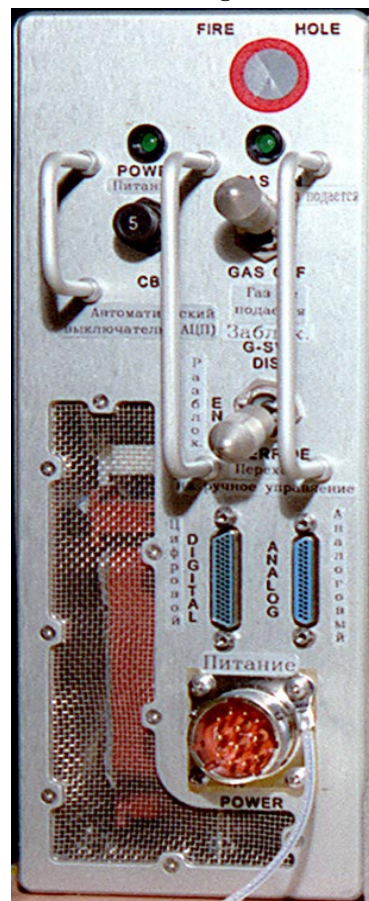

Figure MG-91 COCULT EDU-M

S97-06885

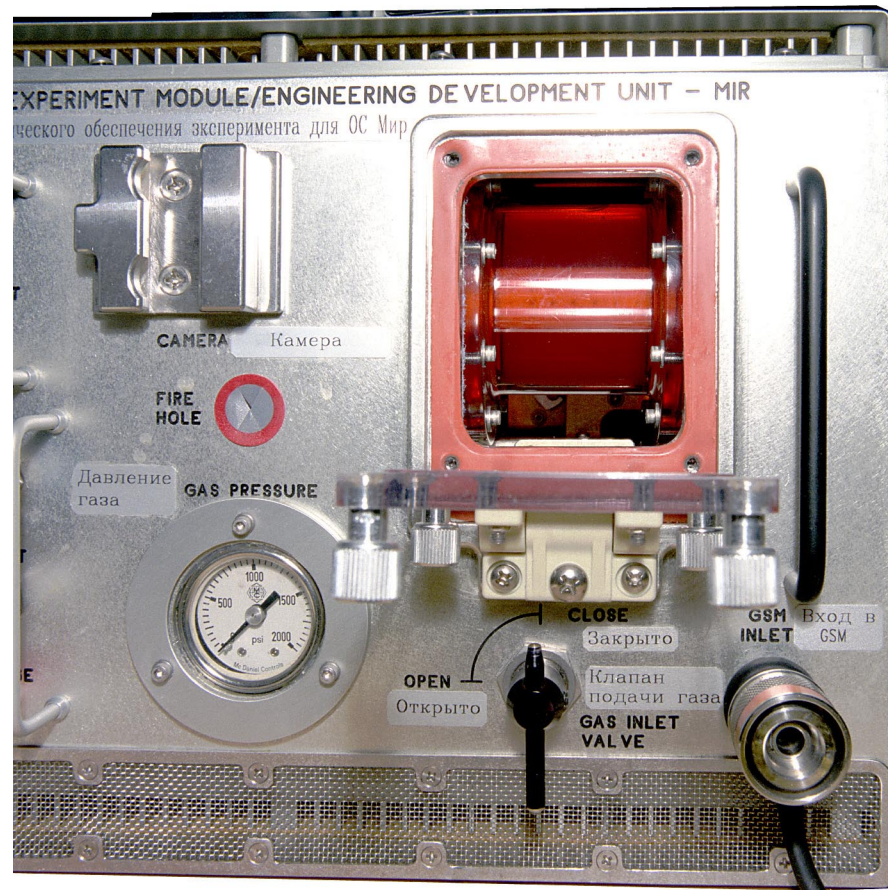

Figure MG-92 COCULT EDU-M Incubation Chamber

S97-06931

TABLE MG.7  
EDU-M INDICATORS AND CONTROLS

Panel Nomenclature	Type of Feature	Description	Function Significance
G-SWITCH	G-sensor control	3-position toggle	Enables/Overrides G sensor or bypasses sensor.
GAS SWITCH	Enables gas system	2-position toggle	Turns ON/OFF operations for gas supply system.
POWER CIRCUIT BREAKER	Experiment ON/OFF switch	5A round push to reset	Removes all power from experiment enclosure when opened.
ANALOG DIGITAL	Data connector	Pin-type D connector	Provides data interface between experiment and BCM. Both connectors are pigtailed to the DATA J1 connector on the BCM.
POWER	BCM Input Power Interface	Pin-type power connector	28 +5, -4 Vdc power feed from BCM
INTERIOR LIGHT	Engages/Disengages interior light	Momentary push-button	Illuminates vessel for crew viewing/camera recording.
INLET PORT	Fluid sampling port	Luer lock	For contingency manual feeding of the reactor vessel.
TISSUE SAMPLE PORT	Cell sampling port	Luer lock	For collecting samples from reactor vessel - can only be accessed when experiment is partially withdrawn from locker.
OUTLET PORT	Fluid sampling port	Luer lock	For collecting media samples exiting vessel.
VIEWPORT	Window		For vessel viewing.
EXCHANGE PORT	Waste removal/Fresh media fill	Luer lock	For removal of expended media and filling fresh media of internal reservoirs.
JOG SWITCH	Control vessel rotation	Two-position toggle	While in start position, it enables slow rotation of vessel and positioning for cell sampling. In stop position when not in use.
CAMERA ATTACHMENT			Positioning camera for recording experiment activity.
GAS	GAS enable light	Green LED	ON indicates active gas system.
PWR	Power on light	Green LED	ON indicates experiment power ON.

Note: The flight EDU-M has foam attached around the outside.

#### EDU-M

P/N: SED32104859-002  
Qty: 1  
Mass: 25.4 kg  
Power: 110 W  
x,y,z: 53.34 x 41.53 x 22.86 cm  
Loc: Priroda

Power Consumption:  
EDU/ECC 118-158 W  
BTR 120-235 W

Start Up Current:  
EDU/ECC 50A; 46msec  
BTR 50A; 19msec

Onboard Electrical Supply:  
DC Source  
23-32V Insulation

Resistance:  
20 Mohm  
(1 Mohm high humidity)

Temperature:  
+5°C - +40°C

Gas Environment:  
78% Nitrogen  
40% Oxygen  
3% CO2  
2% H  
.01% He

Air Pressure:  
450-970 mm Hg

Humidity:  
10-80% (at nominal temp.)  
95% for 3 hours

Acceleration:  
per Shuttle reqs.

Vibration:  
per US/R-002

Shock: per Shuttle reqs.

Noise Generation:  
<60 Db at 1 meter

Operational Life:  
≥8,000 hours



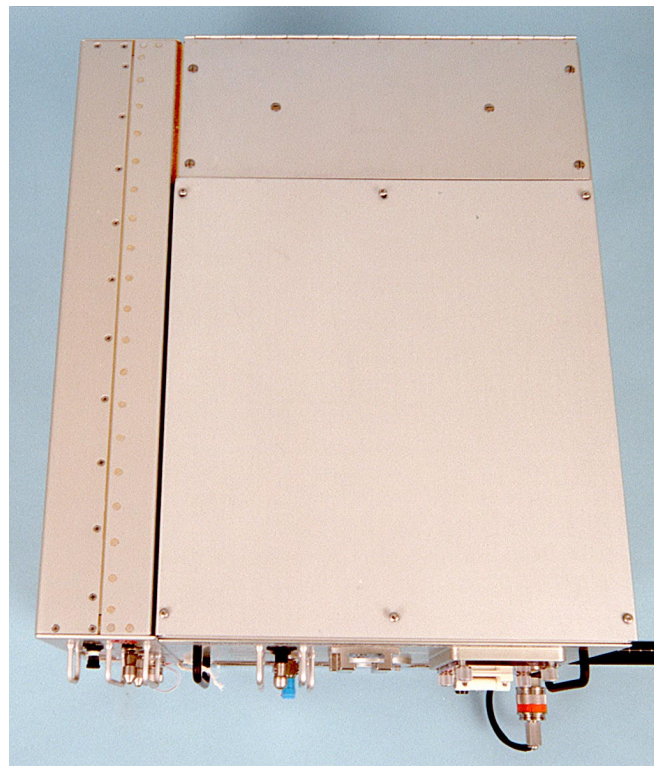

Figure MG-93 EDU-M Top

S97-10561

The EDU-M consists of a reactor vessel, a fluid system, temperature control system, gas support system, and support electronics. During the increment the EDU-M will be located in the BioTechnology System (BTS) within the BEM in Priroda.

**EDU-M HARDWARE INTERFACE WITH SYSTEMS**

The EDU-M requires 27 +5/-4V DC provided by the BTS Computer Module

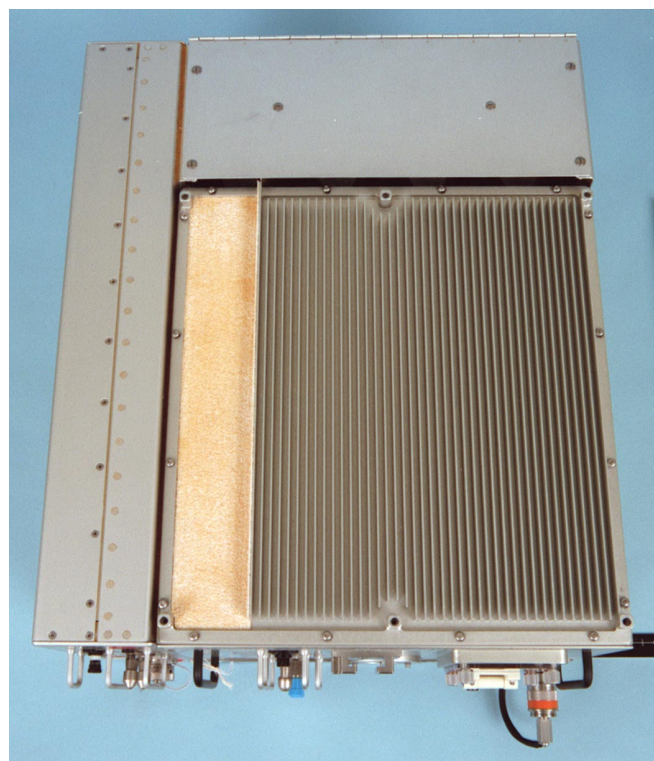

Figure MG-94 EDU-M Top Panel Removed

S97-10560

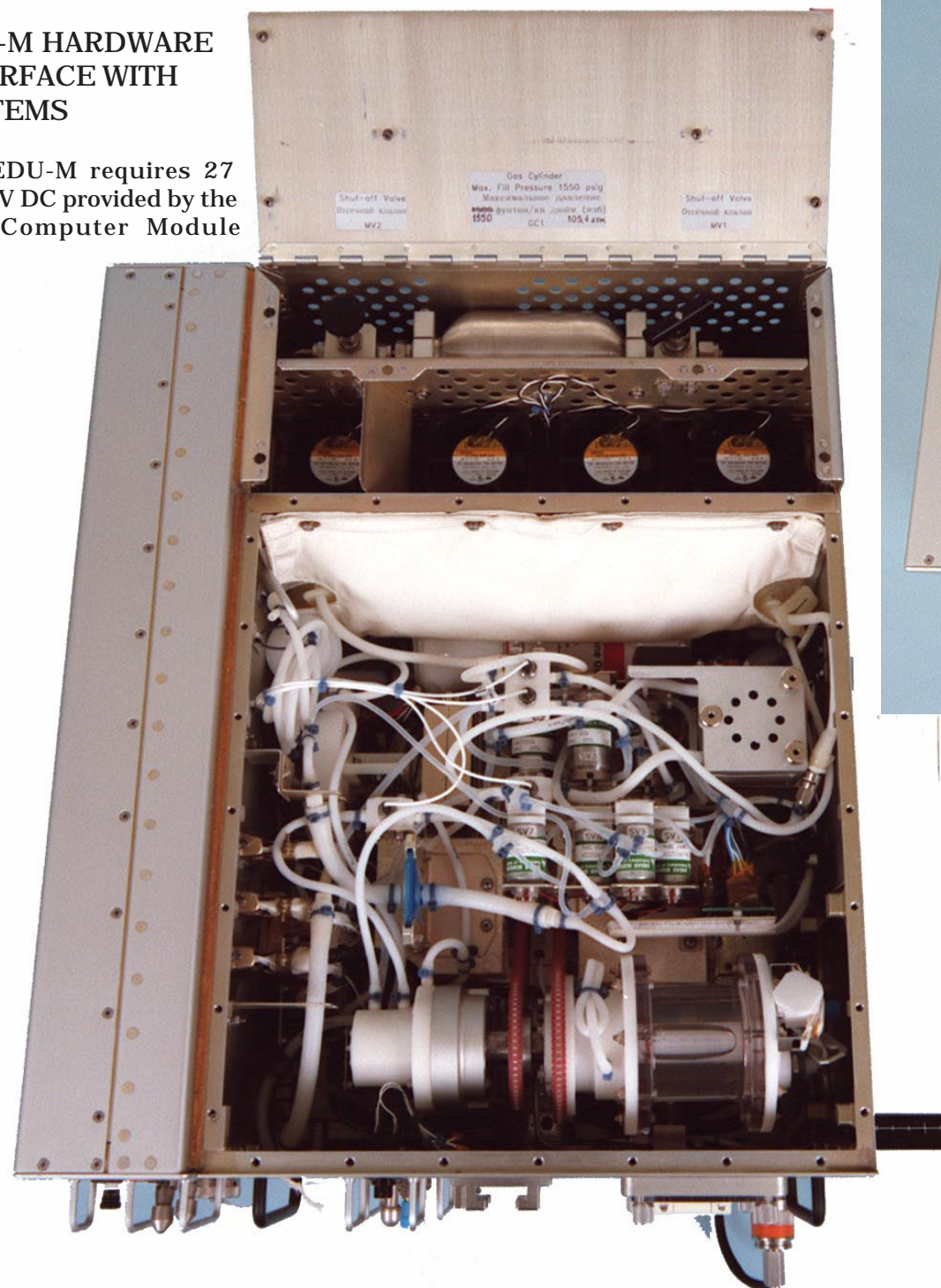

Figure MG-95 EDU-M Top Rear Panel Opened

S97-10558

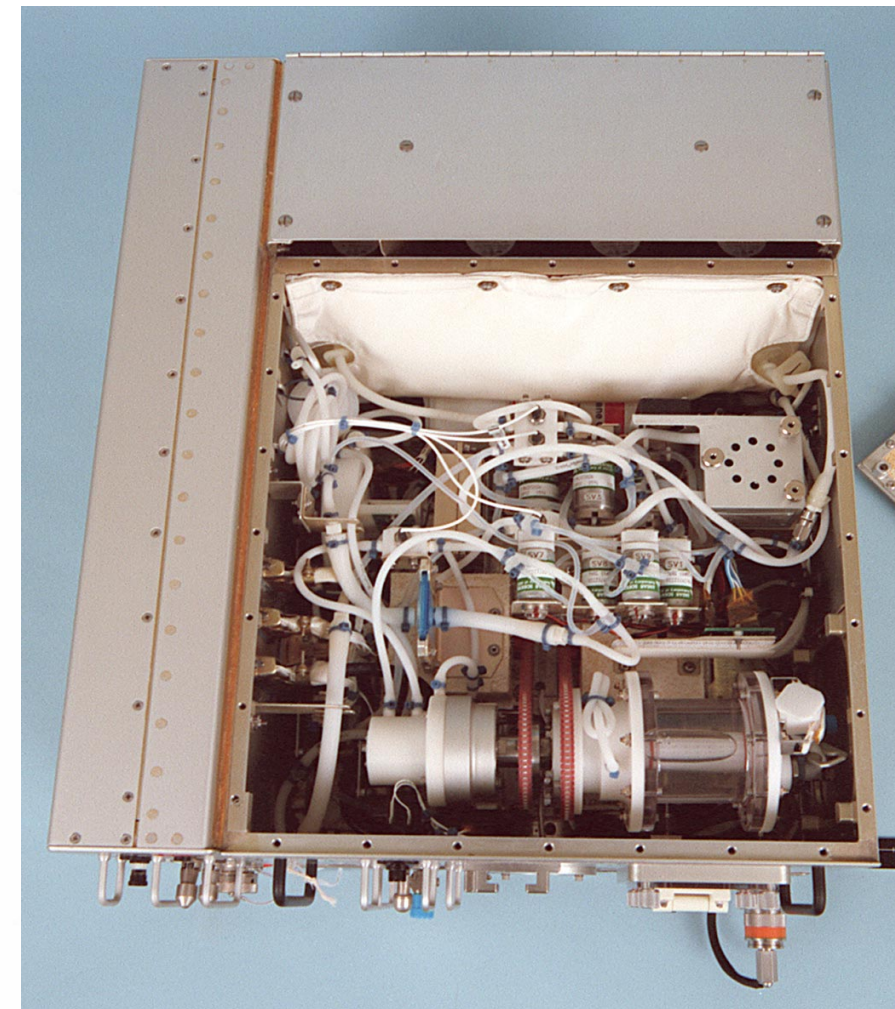

Figure MG-96 EDU-M Secondary Panel Removed

S97-10559

Prior to transfer to Mir, the side panel will be replaced with a glove bag adapter ring. The ring configuration only crosses the Mir hatch.

**POWER CABLE ASSEMBLY (ECC TO BEM)**

P/N: 10108-10082-01  
 Qty: 1  
 Mass: 0.18 kg  
 Power: 0  
 x,y,z: 135 x .53 x 0 cm  
 Loc: Priroda  
 DID#: SLM46111517

**BTS-EDU DATA CABLE**

P/N: SED46107308-303  
 Qty: 1  
 Mass: 0.83 kg  
 Power: 0  
 x,y,z: 121.9 x 2.16 cm  
 Loc: N/A  
 DID#: SLM46111517

**ECC POWER ADAPTER CABLE**

P/N: KLSI240720-701  
 Qty: 1  
 Mass: 0.18 kg  
 Power: 0  
 x,y,z: 35 x 3.3 x 0 cm  
 Loc: N/A  
 DID#: SLM46111518  
 \*1 additional one in the Resupply Kit #1

**EXPERIMENT CONTROL COMPUTER (ECC) FOAM ASSEMBLY**

P/N: SED46112606-303  
 Qty: 1  
 Mass: 1.27 kg  
 Power: 0  
 x,y,z: 51.61 x 43.97 x 12.32 cm  
 Loc: Priroda  
 DID#: SLM46111518

(BCM) via J6 out connector using the experiment-supplied power cable.

The EDU-M requires data and control interface connected via BCM DATA J1 using an experiment-supplied data cable.

The EDU-M requires air and carbon dioxide mixture provided via the Gas Supply Module (GSM) using the facility-supplied flex hose.

**EDU-M DISPLAY AND CONTROLS**

See Table MG.7 for EDU-M Indicators and Controls.



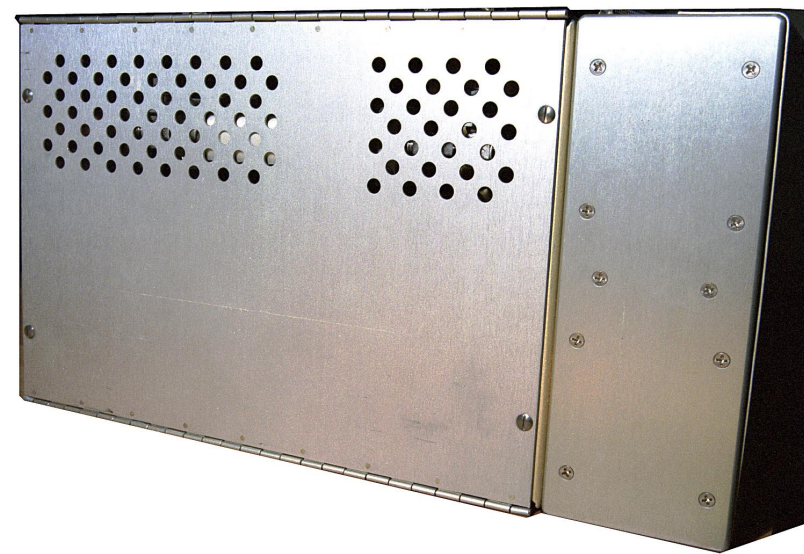

Figure MG-97 EDU-M Back Panel

S97-06933



Figure MG-99 EDU-M Front with Glove Bag Attached (Note That the "X" on the Ring is Facing Front.)



Figure MG-98 EDU-M Right Side with Glove Cover Assembly

S97-17784

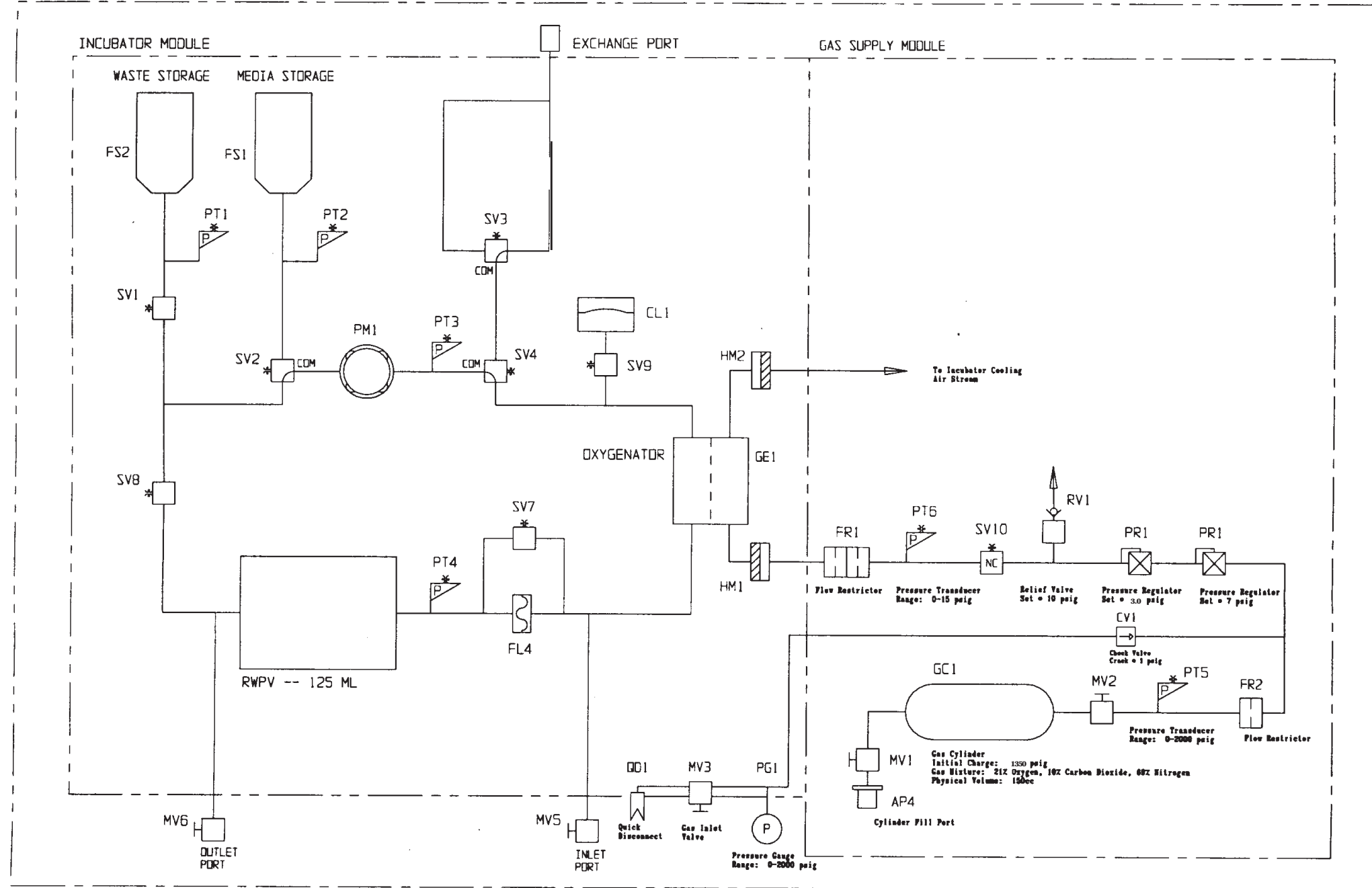

Figure MG-100 EDU-M Right Side with Glovebag Window Assembly Removed

S97-17785



BIOREACTOR ENCLOSURE



LEGEND

NC = NORMALLY CLOSED WHEN UNENERGIZED  
 RWPV = ROTATING WALL PERFUSED VESSEL  
 COM = COMMON PORT

SYSTEM FLOW DIAGRAM  
 EDU-MR

REV 03

Figure MG-101 EDU-M System Flow Diagram

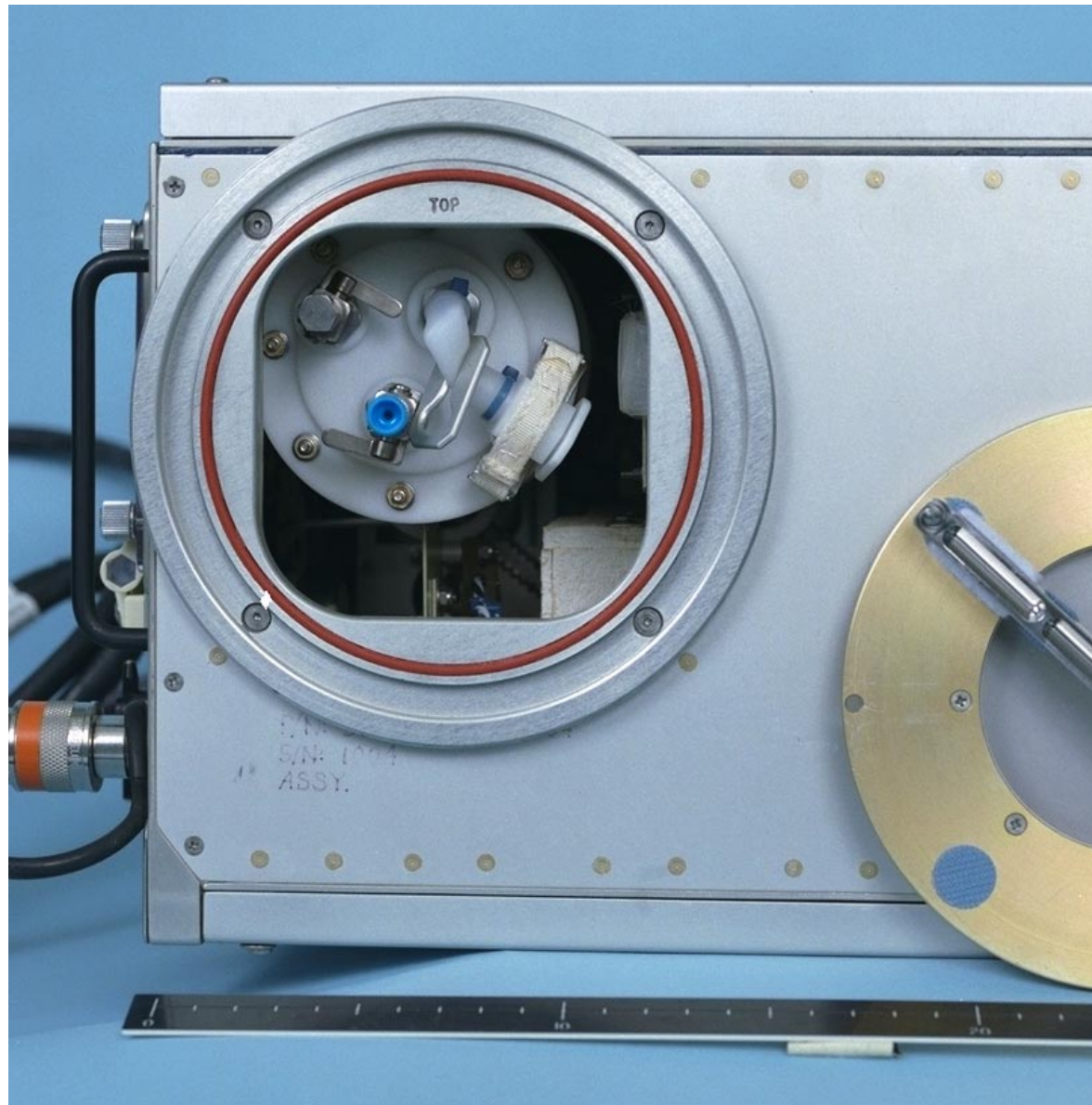

Figure MG-102 EDU-M Right Side Internal View

S97-17786



Figure MG-103 EDU-M Window Removal Tool

S97-17791

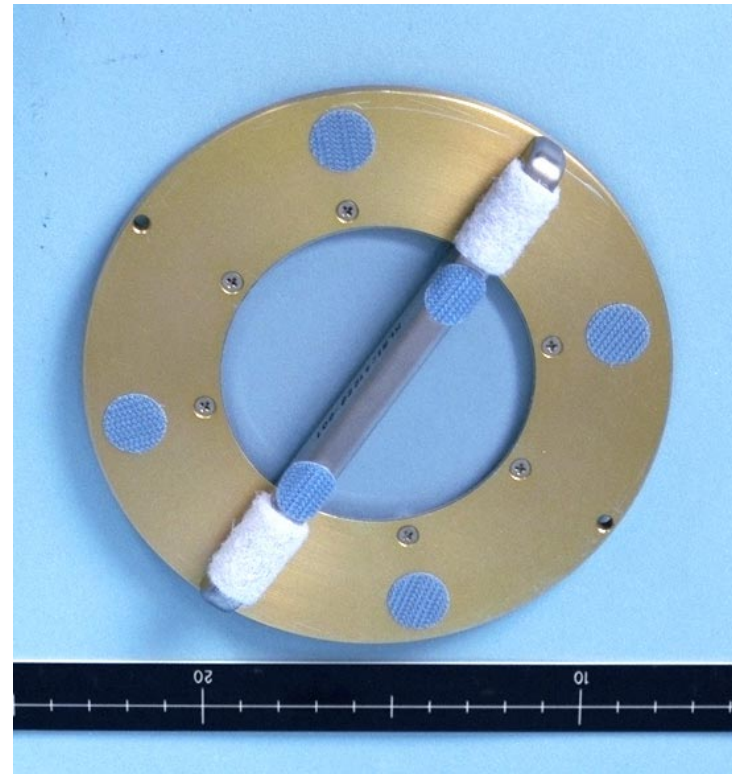

Figure MG-104 Glovebag Window Assembly with Window Remover Tool Used as a Handle

S97-17789

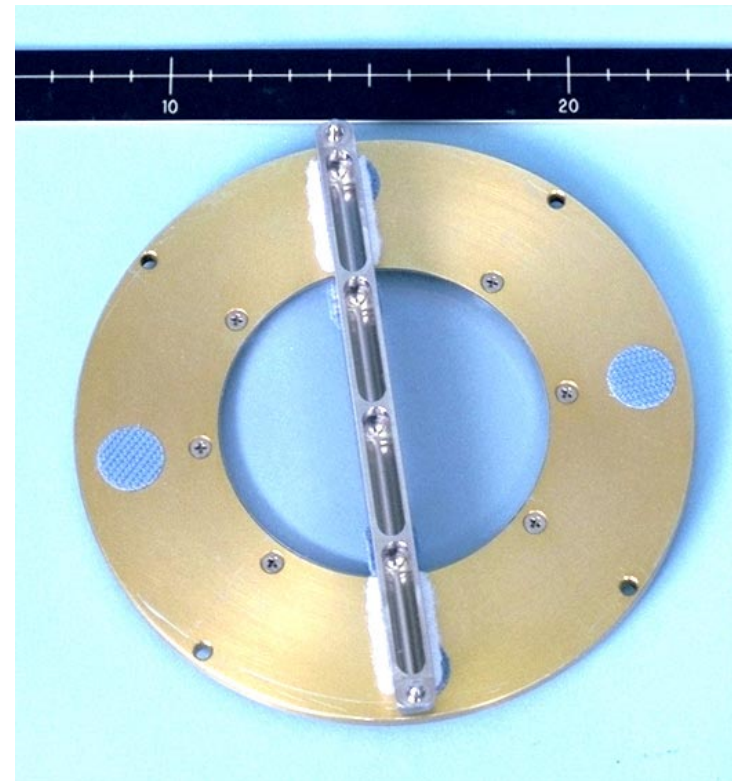

Figure MG-105 Glovebag Window Assembly with Tool in Holding Position

S97-17790

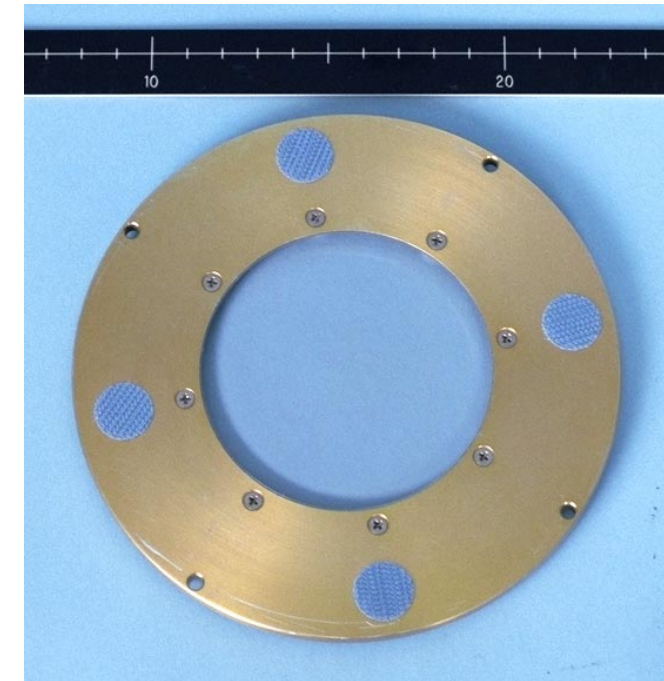

Figure MG-106 Outside Face of the Glovebag Window Assembly

S97-17801

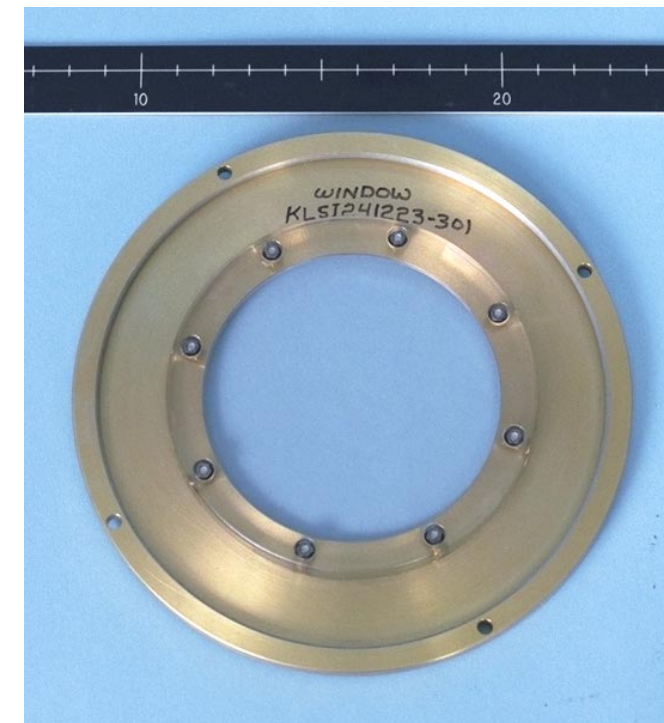

Figure MG-107 Inside Face of the Glovebag Window Assembly

S97-17800





Figure MG-108 EDU-M Glovebag

S97-17787

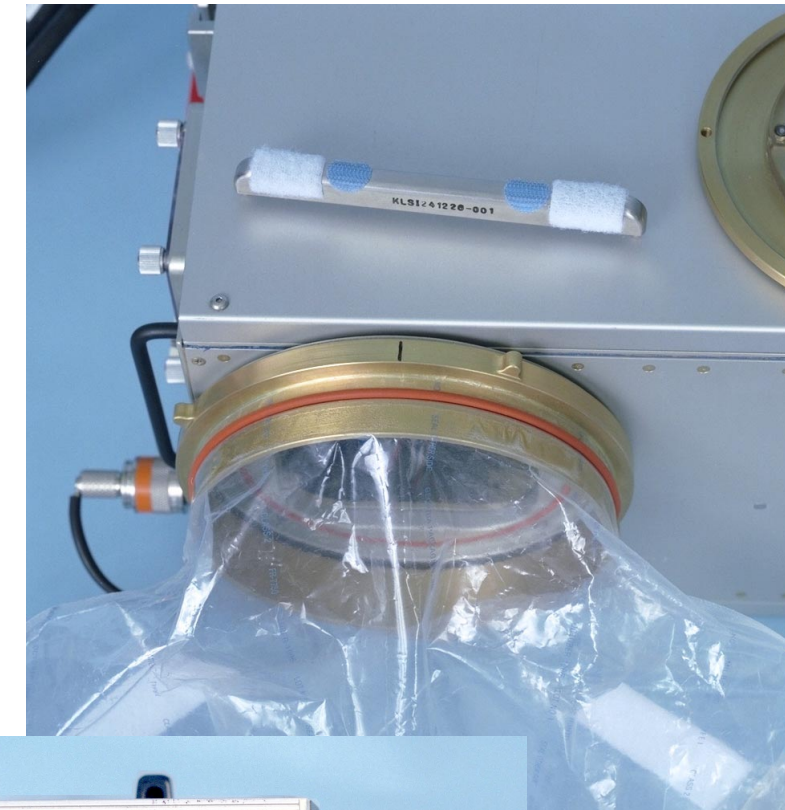

S97-17796

Figure MG-109  
EDU-M Showing the  
Ring in the Locked  
Configuration



S97-17798

Figure MG-110 EDU-M/ECC Data Cable Assembly





Figure MG-111 Stowage Caddy Outer Pockets

S97-17793

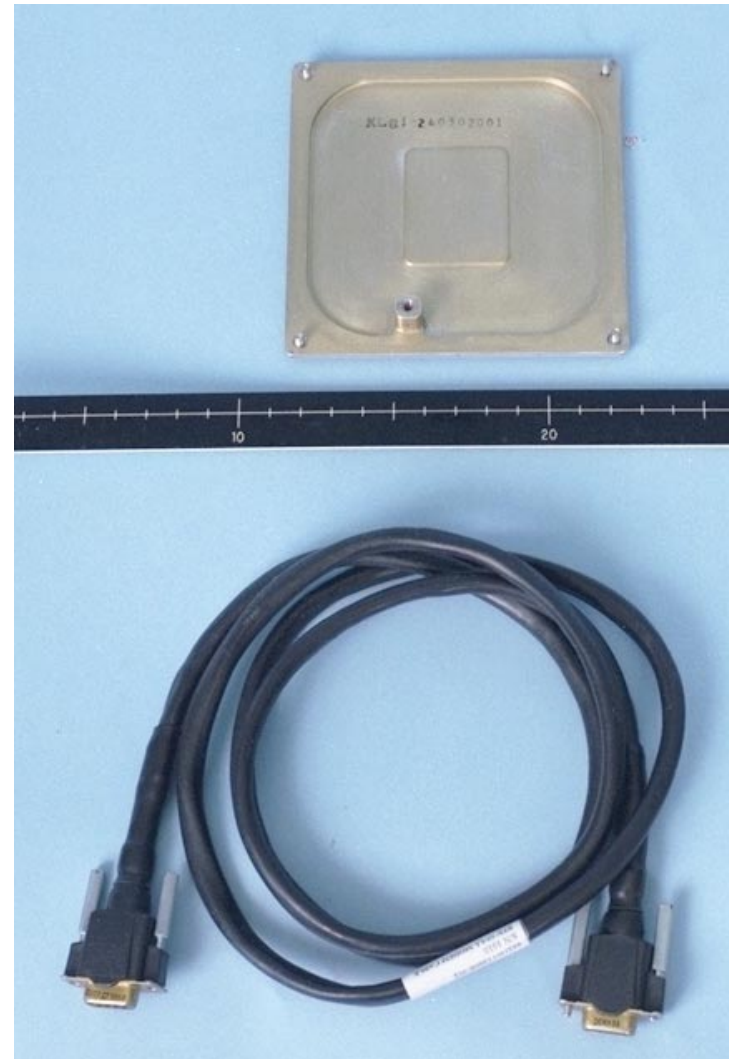

S97-17794  
Figure MG-112 Caddy Outer Pocket Contents (Data Cable and EDU-M Side Plate)



Figure MG-113 Caddy Outer Pockets' Contents

S97-17795

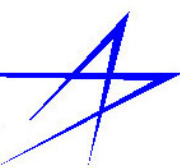

## **BIOTECHNOLOGY REFRIGERATOR (BTR) HARDWARE DESCRIPTION**

### **BTR COMPONENTS**

#### **Single-Loop Process Controller**

The Single-Loop Process Controller functions as the temperature and setpoint display as well as the controller for many of the BTR functions. The unit contains two 51-segment bar graph displays, two 4-digit Light Emitting Diode (LED) numeric displays, inputs for an interlock switch, an optically isolated RS-232 port, a 0 to 5V DC DAC output, a 10A relay, and inputs for a setpoint switch. The DAC output of this unit supplies the Modulation Input Voltage to the Temperature Controller. The setpoint switch input sets the voltage output of the DAC. The setpoint is displayed on one of the numeric displays while the actual temperature is displayed on the other. A signal from the interlock switch causes the 10A relay to open turning off power to the TEC controllers.

Communication with a host computer (MIPS) is achieved through the optically isolated RS-232 port. The setpoint can be set using a host computer (MIPS-2L) running the proper software. Data can also be logged to a host computer via the RS-232. This controller stores its setpoint data and program in nonvolatile Random Access Memory (RAM).

#### **Fan Speed Controllers**

These units control the amount of current supplied to the cooling fans by monitoring the temperature of the air entering the BTR. Under normal conditions the fan will be running at about 50% of its rated voltage. If the air temperature rises above a specific preset value, the current to the fan will increase proportionally until the fan is running at full speed. The full speed condition will occur when the ambient temperature reaches approximately 40 °C.

#### **Setpoint Switch**

This is a momentary three-position locking-lever toggle switch with the center position being the lock. To increase the setpoint value, lift the lever and hold. The setpoint display will start to increase in 1 degree increments once every 5 seconds.

Releasing the lever returns it to the locking position. To decrease the setpoint, push the lever down.

#### **Interlock Switch**

This switch causes the power to the entire unit to be turned off when the BTR drawer is opened. Closing the drawer causes the power to be reapplied to the entire unit.

#### **Circuit Breaker**

The front panel contains a resettable circuit breaker as a safety precaution for short circuits. It also doubles as a power switch.

#### **Power Connector**

The Power Connector is the power interface for the unit. It receives 28V DC from the PUP.

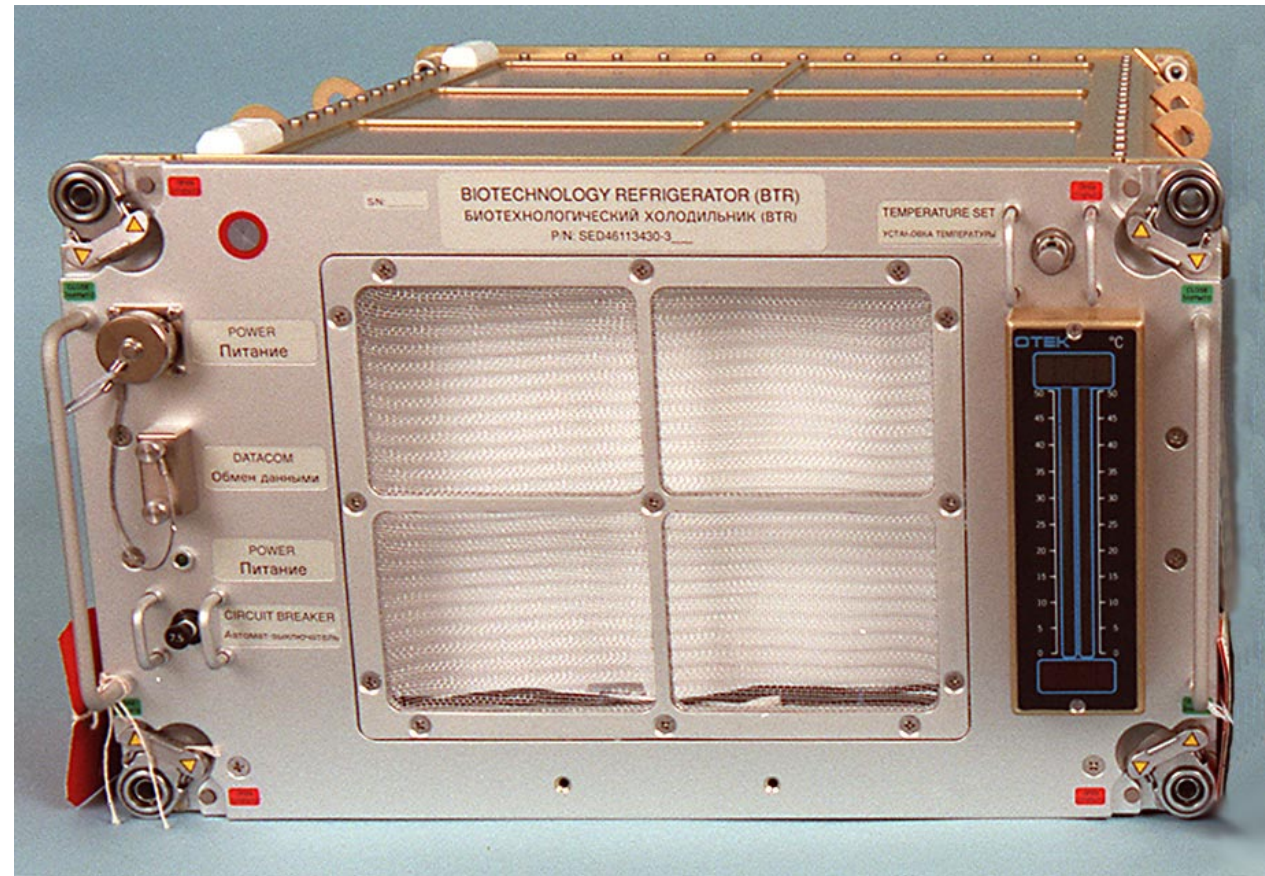

Figure MG-115 BTR Front Panel (The Fire Holes Will Be Covered)

S97-05313

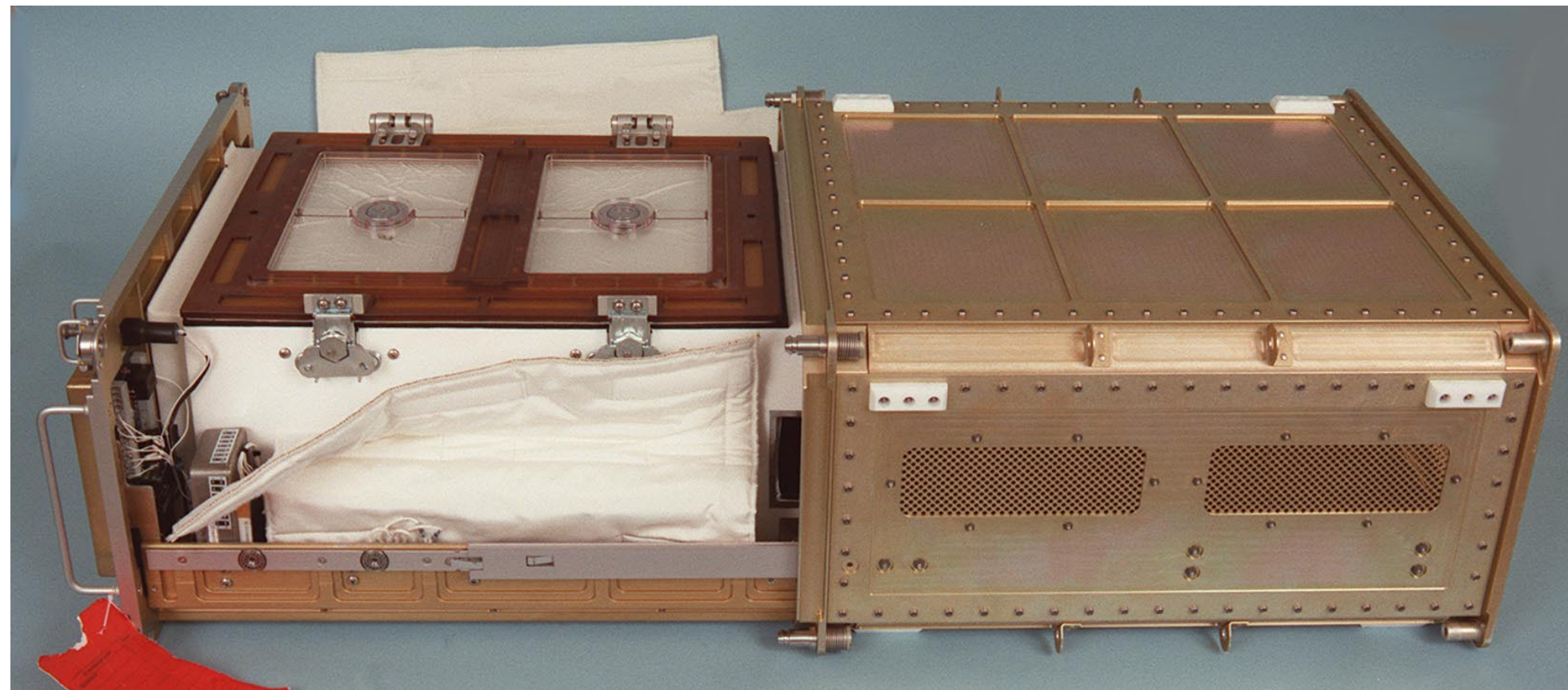

Figure BTR-114 BTR Pulled Out of Its Locker (The Wires Behind the Temperature Set Switch Have Since Been Strengthened)

S97-05324

D.I.D.

BTR

#### **BIOTECHNOLOGY REFRIGERATOR (BTR)**

P/N: SED46113430-302  
Qty: 1  
Mass: 29.82 kg  
25.66 (w/o contents)  
Power: 171 W  
x,y,z: 58.42 x 46.84 x 28.52 cm  
Loc: Priroda, SIC3-I-2  
DID#: SLM46115279  
Start-up Power at 27V:  
36.6 amps/ 2.5  
milliseconds  
Insulation Resistance:  
>20 Megaohms



## Temperature Controller

A commercially available controller for Thermoelectric Cooler Modules is used. These units use thermistors to feedback temperature information for use by their on-board PID controllers. There will be two of these units on board the BTR setup in a master/slave configuration. These units are basically configured in series with the TEC modules and control the amount of current delivered to the TECs.

The farther away the actual temperature is from the setpoint the more current the controller supplies to the TEC. The setpoint can be set by using a potentiometer built into the unit or by supplying a voltage between 0 and 5V DC to its Modulation input pins. In the case of the BTR, the Modulation Input Voltage will come from the Single-Loop Process Controller located on the front panel of the BTR.

## BTR DISPLAYS AND CONTROLS

See Table MG.8 for BTR Indicators and Controls.

## BTS-COCULT POWER

Cocult's EDU-M requires approximately 156W at 32V DC peak and 132W at 27V DC nominal. This includes ECC operation. No laptop is connected. The BTS BCM requires approximately 65W peak and 50W nominal.

The BTR requires approximately 235W at 32V DC peak and 171W at 27V DC nominal. These values are dependent upon ambient temperature and the setpoint.

The GSM does not require power.

TABLE MG.8  
BTR INDICATORS AND CONTROLS

Item	Type Device	Function	Usage (Time & Frequency)
CIRCUIT BREAKER	Circuit breaker, 7.5 amp, two position PWR-maintained OFF-maintained	PWR-applies 27 +5/-4 Vdc power to the BTR. OFF-removes power from the BTR	Set to PWR before launch and remain in PWR until deactivation
POWER	Power connector	Input power connector	Used during integration and on-orbit operations.
DATAKOM	RS-232 connector	Communication port for external devices	Used for communications with BEM/BSTC-M, Experiment Control Computer (ECC), PGSC, MIPS-2L, or other external devices (required for malfunctions only).
POWER	Green LED	ON-power applied to BTR	Illuminated when unit is powered.
TEMPERATURE SET INCREASE DECREASE	Three-position toggle switch	Allows user to manually increase or decrease the temperature setting of the BTR	Temperature is preset prior to launch (used only for experiment replanning or malfunctions).
Display Screens  - Upper - Lower	Digital display  (green) (red)	Displays digital setpoint and actual temperature  Temperature setpoint Actual Temperature	Used for status display during nominal operations throughout all phases of the mission.
Graphs	LED graph	Displays graphical representation of setpoint and actual temperature	Used for status display during nominal operations throughout all phases of the mission.



Figure MG-116 BTR Left Side

S97-05318



Figure MG-117 BTR Front Left Side Showing Internal Temperature Gauge

S97-05319

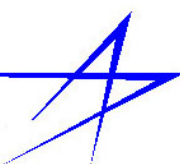

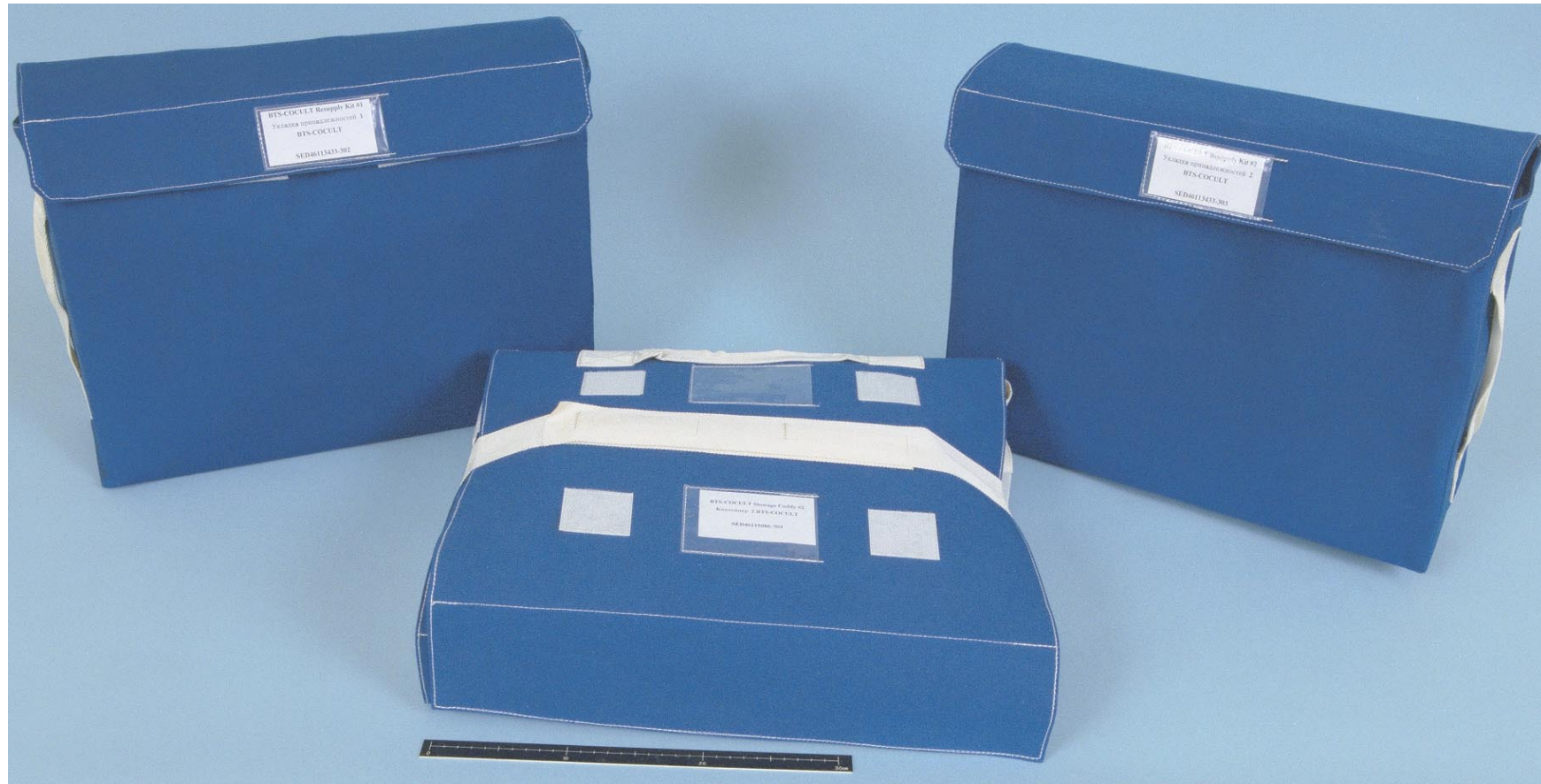

Figure MG-118 BTS-COCULT Stowage Caddy and Resupply Kits

S97-16654

**BTS-COCULT AMBIENT STOWAGE  
HARDWARE DESCRIPTION**

The BTS Ambient Stowage is composed of three primary elements: the Stowage Caddy #2, the Resupply Kit #1, and the Resupply Kit #2.

**STOWAGE CADDY #2**

Stowage Caddy #2 provides the experiment operator with most of the consumable items necessary to conduct the majority of on-orbit procedures such as media and tissue sampling. The caddy folds out in multiple sections revealing pallets and stowage pockets containing these items. The caddy also contains a number of tools and other procedural aids that are used routinely throughout the mission.

**RESUPPLY KIT #1**

Resupply Kit #1 is a briefcase-sized soft container which primarily stows extra consumable items used to replenish items in Stowage Caddy #2 when they become exhausted during the mission. This Resupply Kit also provides stowage space for items not easily placed in Stowage Caddy #2 such as the Optical Correction Lens Assembly which is an occasional use item.

**RESUPPLY KIT #2**

Resupply Kit #2 is also a briefcase-sized soft container which stows glove bag assemblies used during tissue sampling and contingency procedures. The kit also contains other miscellaneous consumable and non-consumable items used during experiment operations. Of note, the crewmember's experiment logbook is stowed in this kit. \*



Figure MG-119 Resupply Kit #1

S97-16655

**BTS COCULT RESUPPLY KIT #1**

P/N: SED46113433-302  
Qty: 1  
Mass: 5.44 kg  
Power: 0  
x,y,z: 46.48 x 37.98 x 13.54 cm  
Loc: Priroda

**BTS COCULT RESUPPLY KIT #2**

P/N: SED46113433-303  
Qty: 1  
Mass: 4.72 kg  
Power: 0  
x,y,z: 45.72 x 35.56 x 12.70 cm  
Loc: Priroda

**BTS COCULT STOWAGE  
CADDY #2**

P/N: SED46115086-304  
Qty: 1  
Mass: 6.58 kg  
Power: 0  
x,y,z: 46.99 x 40.84 x 13.51 cm  
Loc: Priroda

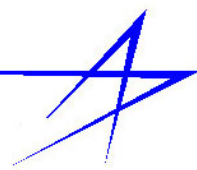



Figure MG-120 Resupply Kit #1 Displayed

S97-16656





Figure MG-121 Absorbent Pads and BZK Wipes Dispensers

S97-16664



Figure MG-122 Batteries, Caps and COCULT Diskettes S97-16661



Figure MG-123 Desiccant Paks, Red Luer Caps and Sterile Gauze Pads

S97-16663





Figure MG-124 Contingency Syringe Pallet With Media Filters and Septums S97-16648



Figure MG-126 ECC Power Adapter Cable S97-16666

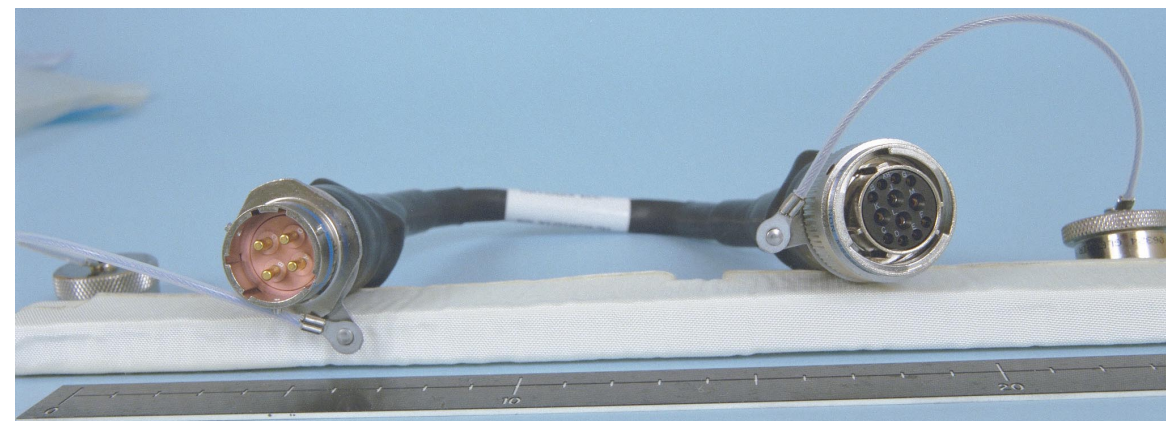

Figure MG-125 ECC Power Adapter Cable Ends S97-16667



Figure MG-127 Media Exchange Filters S97-16669



S97-16675

Figure MG-128 COCULT Stowage Caddy #2  
 Media Sample Syringe Pallet      Omnifix Cell Sample Fixative Syringe Pallet      Contingency Pallet with 5 Media Exchange Filters and 4 Omnifix Cell Sample Syringes



S97-16671

Figure MG-129 COCULT Stowage Caddy Half Closed



Figure MG-130 Left Side of the Stowage Caddy #2

S97-16675



Figure MG-131 Media Syringe Pallet

S97-16665



Figure MG-132 Caddy Contents

S97-16652



Figure MG-133 Middle Section of the Stowage Caddy #2

S97-16673



Figure MG-134 BZK Wipes and Glove Dispenser

S97-16651



Figure MG-135 Right Side of the COCULT Stowage Caddy #2

S97-16676



Figure MG-136 Media Syringe Sample Fixative Syringe Pallet

S97-16653





Figure MG-137 Optical Correction Kit Displayed

S97-16658

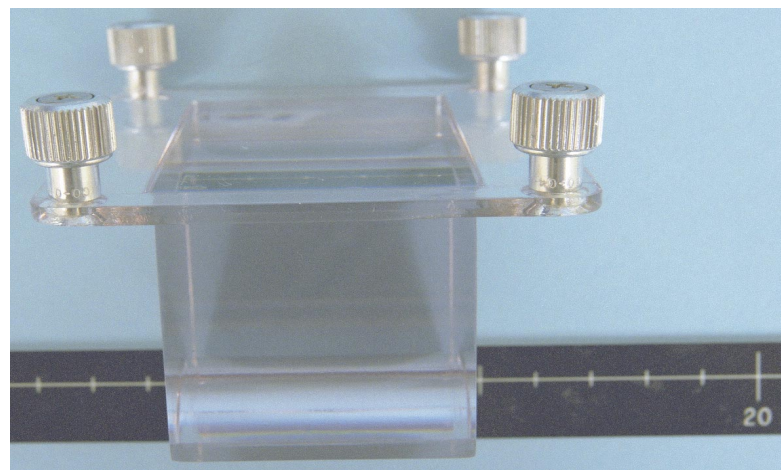

Figure MG-138 Optical Correction Device Side View

S97-16659

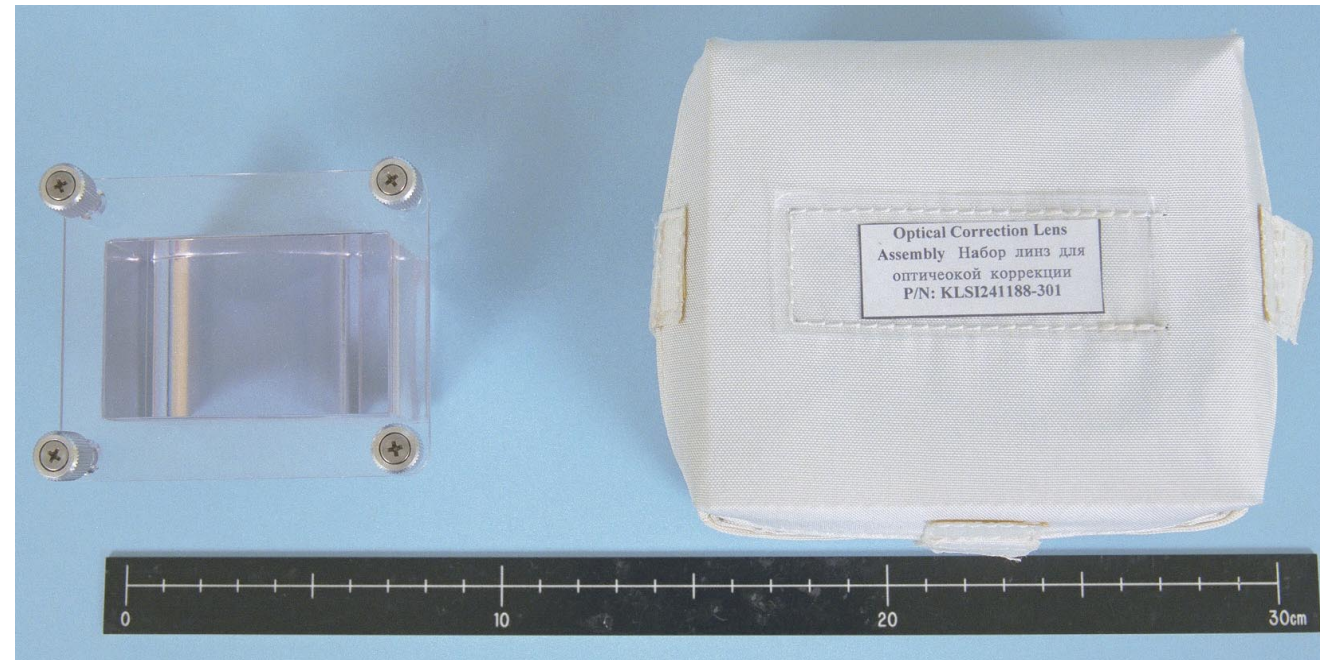

Figure MG-139 Optical Correction Kit

S97-16657

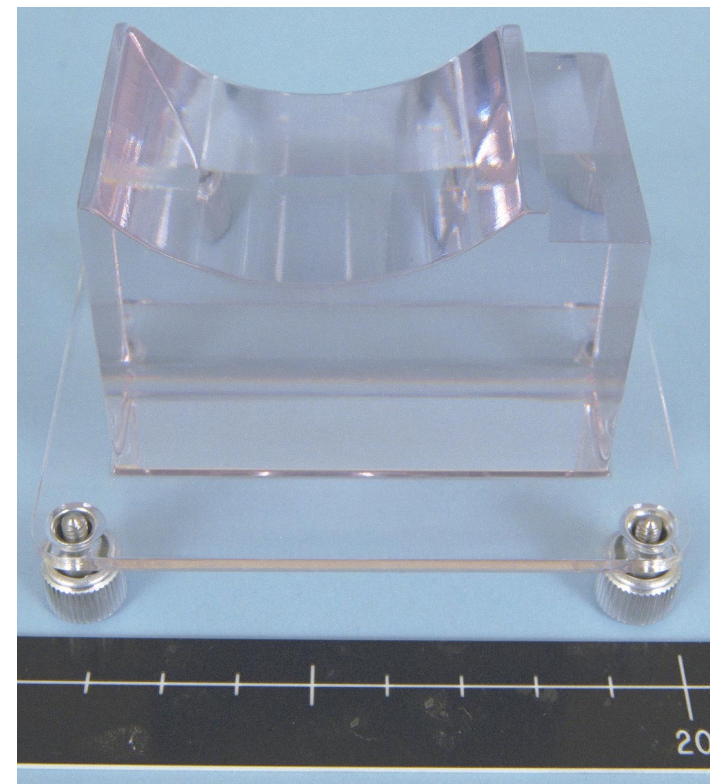

Figure MG-140 Optical Correction Device

S97-16659



Figure MG-141 BTS-COCULT Resupply Kit #2 S97-17397



Figure MG-142 Desiccant Kits and Red Cap Kits S97-17399



Figure MG-143 BTS-COCULT Resupply Kit #2 Opened S97-17398



Figure MG-144 Omnifix Syringe

S97-16670

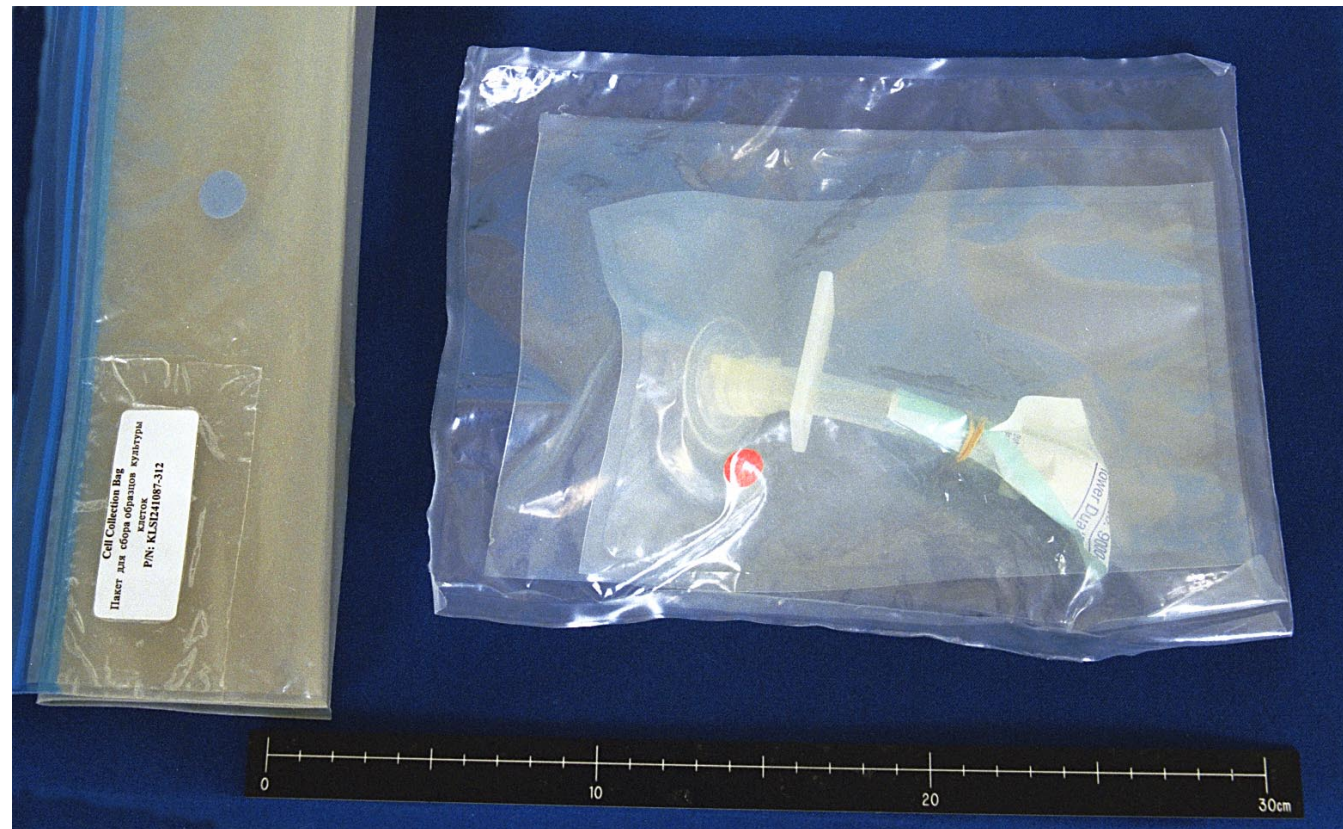

Figure MG-145 Resupply Kit #1

s97-16662



Figure MG-146 Glovebag without Ring

S97-19405

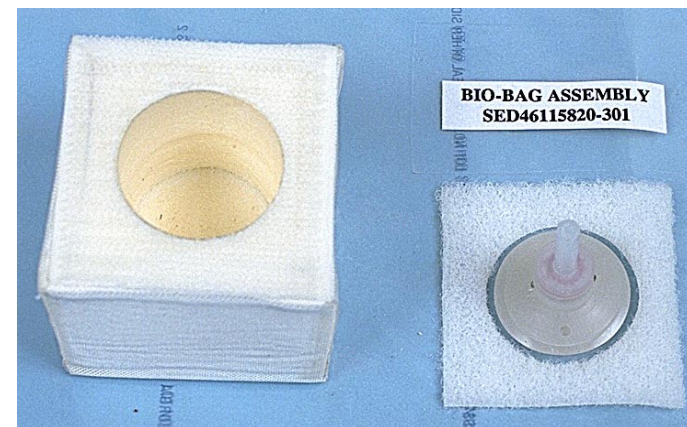

Figure MG-147

BIO Bag Assembly Relief Valve for Pressure Equalization

S97-19406







Figure MG-148 Glovebag

S97-19404

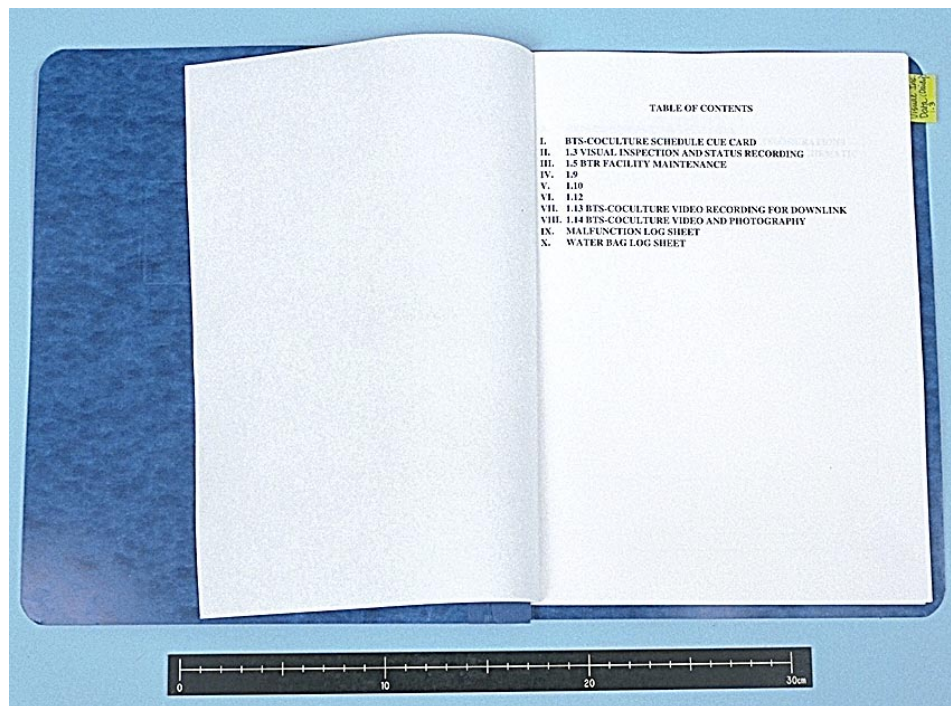

Figure MG-149 COCULT Logbook

S97-17401



Figure MG-150 COCULT Resupply Kit #2 Glovebags, Data Capture Kit, and Logbook

S97-17400



# CANADIAN PROTEIN CRYSTALLIZATION (CAPE)

## HARDWARE DESCRIPTIONS

The proposed flight configuration for CAPE will include one DMDA and one Dual Materials Dispersion Apparatus-Optical Version (DMDA-O), which will be mounted on the MIM in the locker enclosure on the Mir-Priroda Module. The flight configuration will also include one DMDA and one optical DMDA-O, which will not be mounted on the MIM but will be mounted on the wall of the MIM double locker enclosure.

The DMDA is a current upgrade in the MDA Minilab, which has been flown on six (6) Space

Shuttle missions to conduct microgravity biomedical experiments. This upgrade has been accomplished to increase the capacity and add more flexibility to the types of experiments that can be conducted. This Dual MDA (DMDA) will have the ability to automate the crystal growth process and also provide the capability of real-time video data collection with the DMDA-0.

The DMDA is an aluminum housing with an internal, sealed compartment to perform biomedical experiments in the microgravity environment while on orbit. All of the experiments will be performed with three levels

of containment inside of the DMDA housing.

The experiments are conducted in "wells" (or mini-test tubes), embedded in a set of matched "blocks". When the experiment is initiated in a microgravity environment, the blocks are moved, and the fluids, which were separated by the block interface, are brought together and mix in a process conducive to the scientific design of the experiment.

The proposed Mir flight configuration, will provide up to a total of 880 experimental wells in the flight blocks, including 18 optical wells,

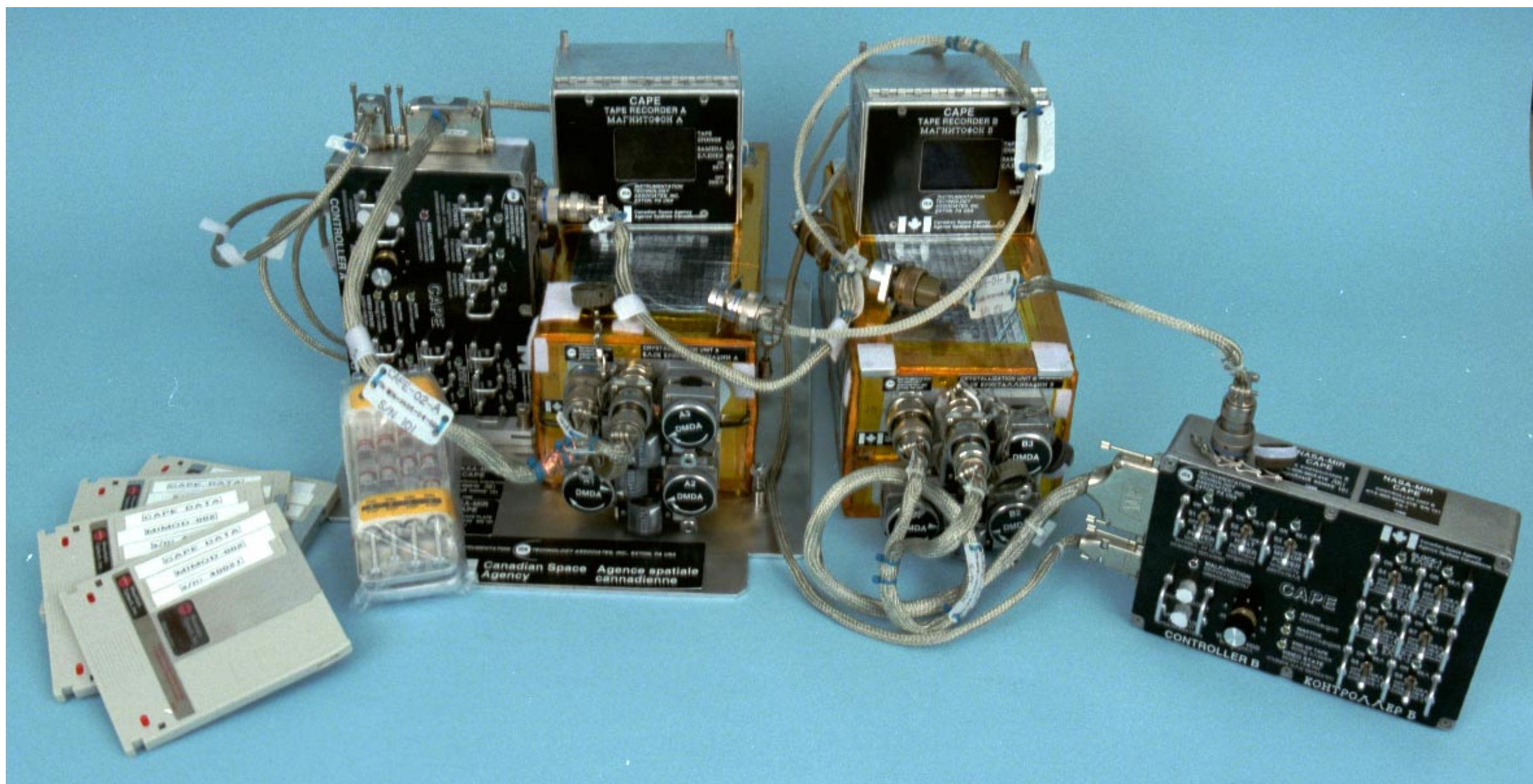

Figure MG-151 CAPE Hardware Components

S97-18367



Canadian Protein  
Crystallization  
Experiment

**Principal Investigator:**  
Dr. Jurgen Sygusch  
University of Montreal  
Quebec  
Professor Biochemistry  
Department  
(514)343-2389

Phil Gregory, CSA  
(514)926-4770

	CAPE
Power Consumption:	12W/60w (heater) max. = 120W
Start-Up Current:	40 amps
On-Board Electrical Supply:	MIM-supplied power
Insulation Resistance:	20 MOhm (1 MOhm high humidity)
Operational Life:	150 days
Shelf life:	5 years



depending on the type and diameter of the wells. The design parameters (size, type and number of wells) are selected based on the scientific requirements. The internal design of the DMDA blocks will be custom modified to satisfy the scientific requirements of the CSA experiment.

The DMDA-O video camera with back lighting, microscopic lens, and camera positioning drive system is contained entirely inside the sealed compartment of the DMDA-O housing. Transparent sections of the "blocks" allow imaging access to the experiment optical wells. The tape-recorder may be externally attached to the DMDA-O housing or may be mechanically separated (except for electrical wires) from the housing when the DMDA is installed on the MIM.

Each DMDA is equipped with a pre-programmed controller for autonomous (or manual) operation on orbit to minimize the responsibilities of the flight crew and enhance the probabilities of success with an automated or semi-automated experiment. A mechanical override capability is also available for block movement to manually initiate the experiment. The controller is contained within the electronics box and is

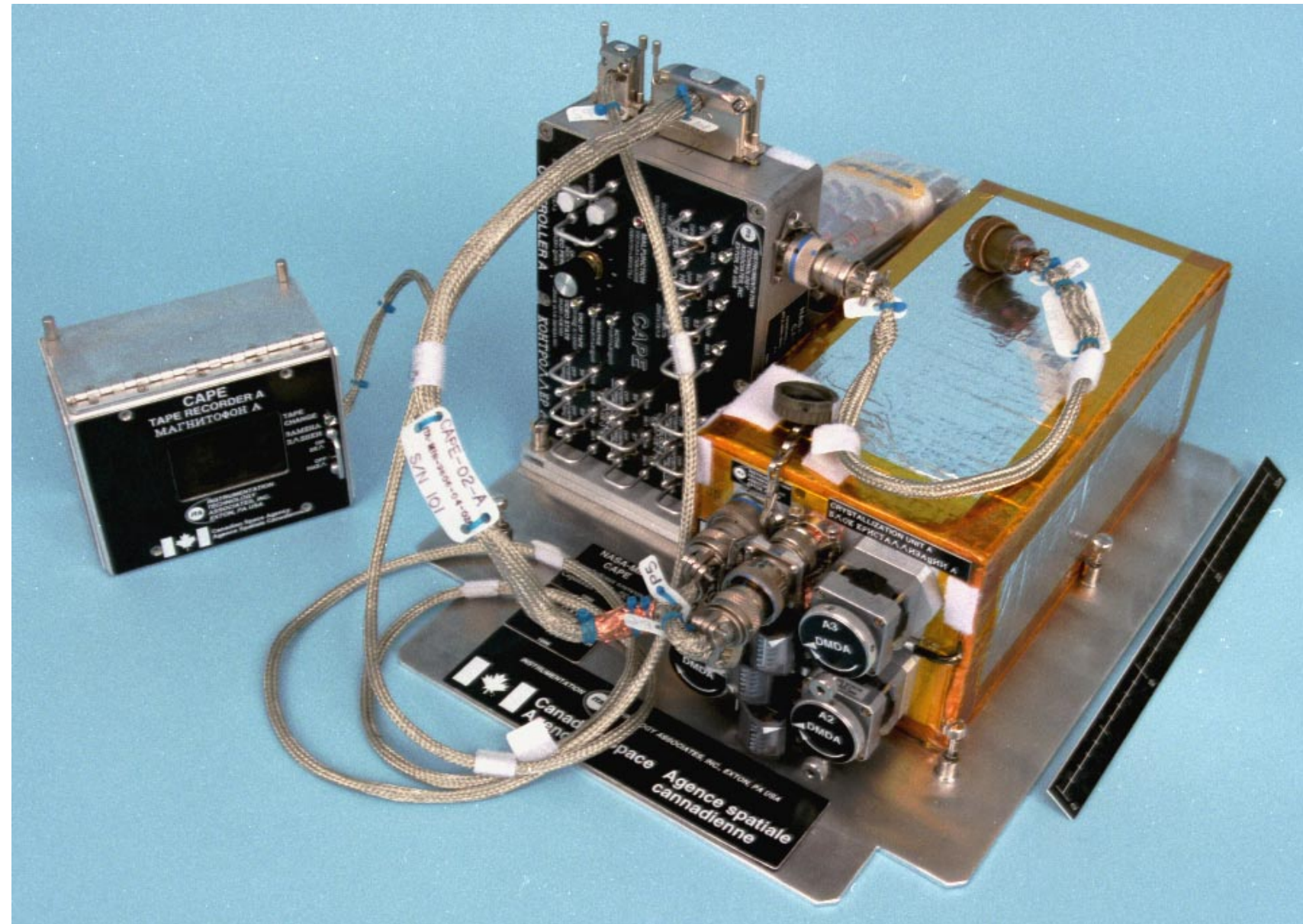

S97-18346

Figure MG-153 CAPE Hardware, Unit A

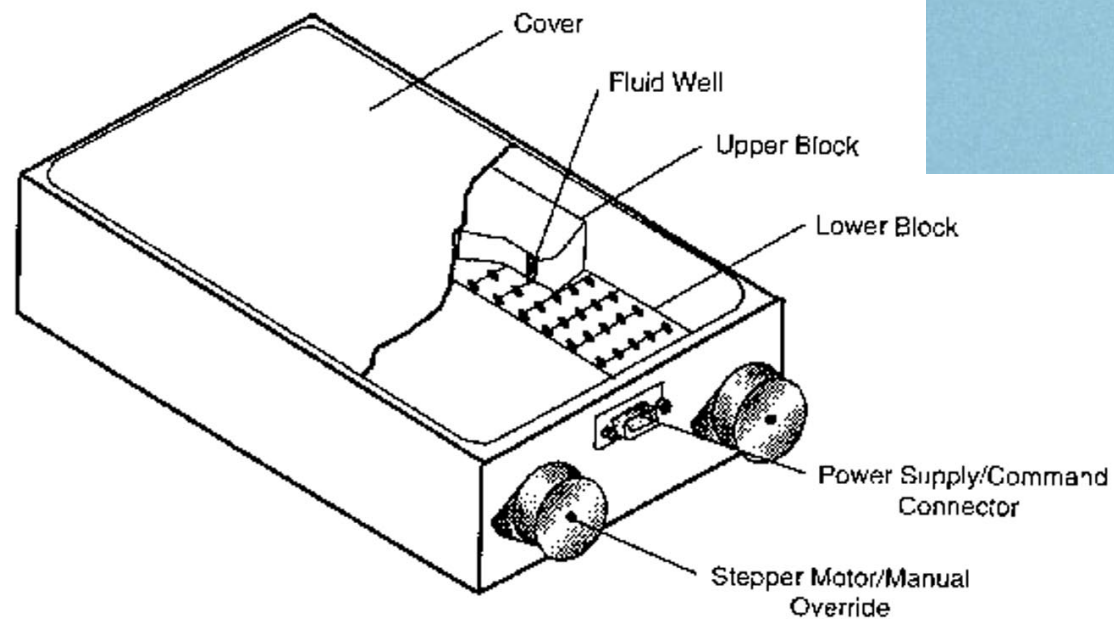

Figure MG-152 Standard DMDA Schematic

connected to the crystallization unit housing. As with the video recorder, the Controller and the electronics box may be mechanically separated from the housing when the housing is installed on the MIM for isolation purposes.

The CAPE flight hardware is designed to interface with the MIM compartment, which interfaces with Mir, in accordance with the Hardware General Design Standards and Test Requirements, US/R-002. \*

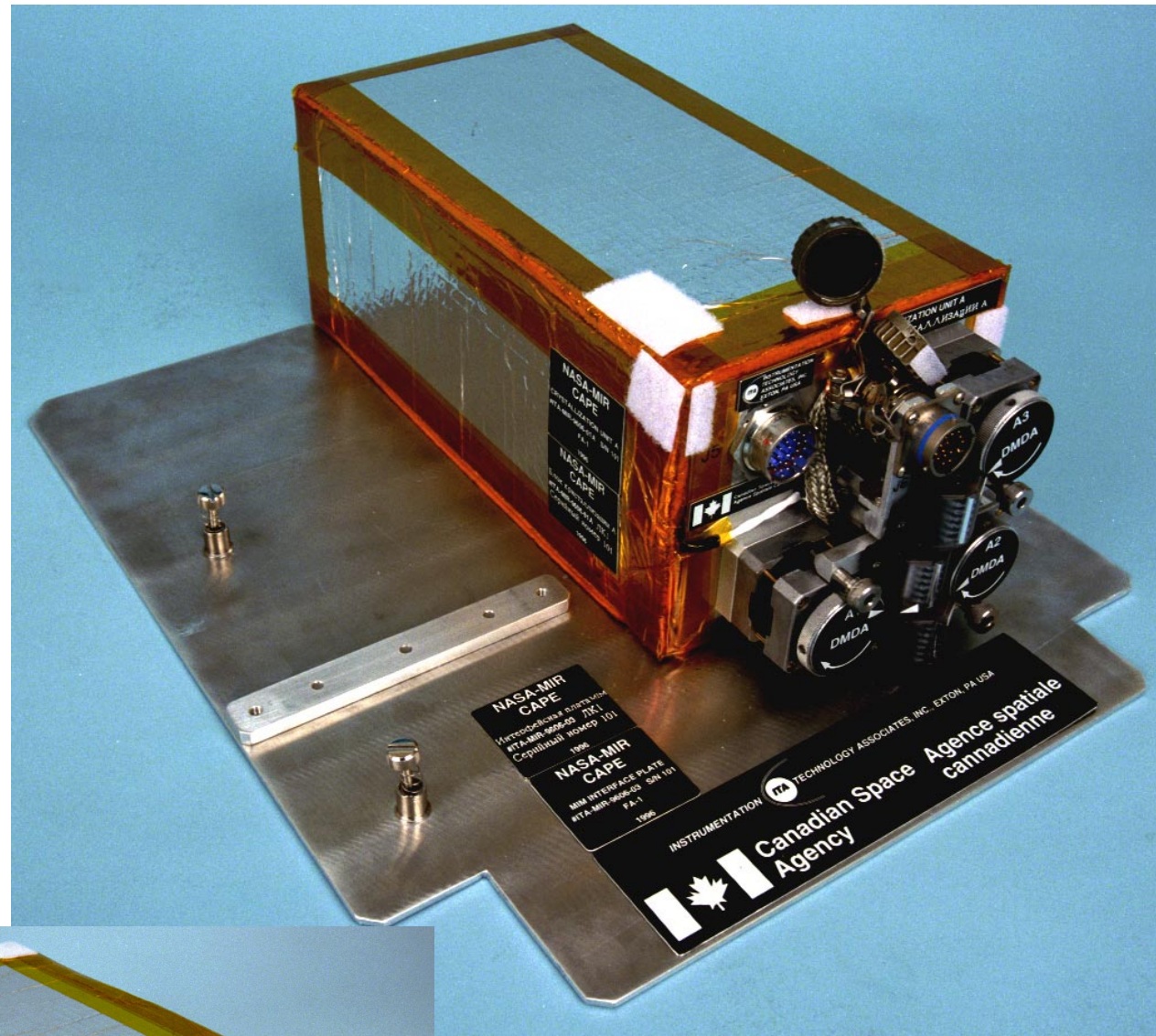

Figure MG-154 Crystallization Unit A on MIM Mounting Plate S97-18276

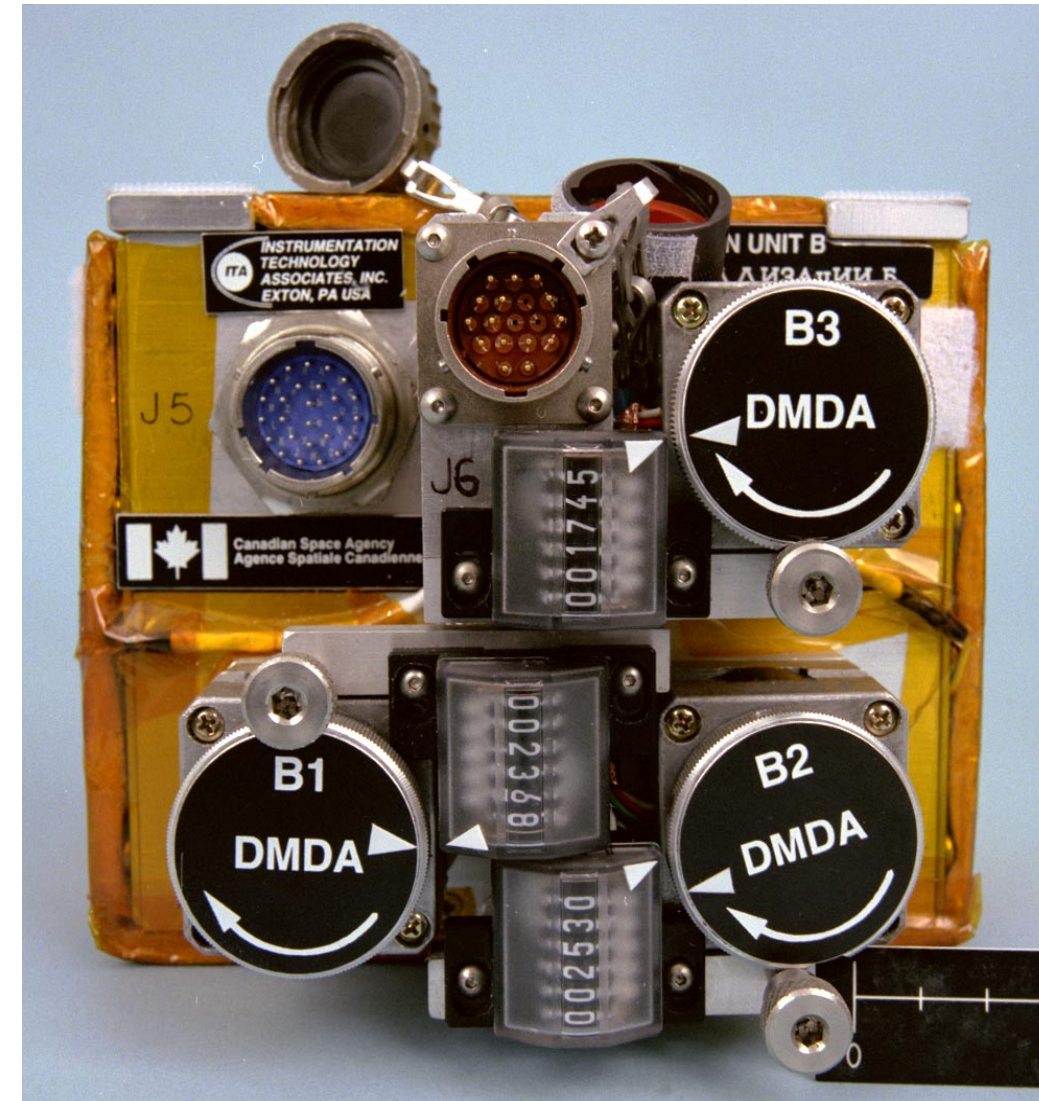

Figure MG-157 Crystallization Unit B End View S97-18296

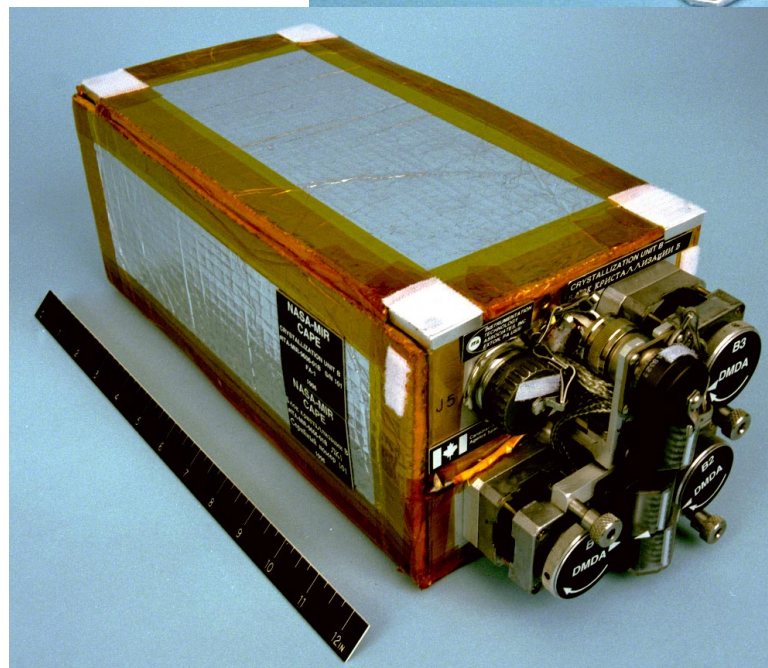

Figure MG-155 Crystallization Unit B S97-18297

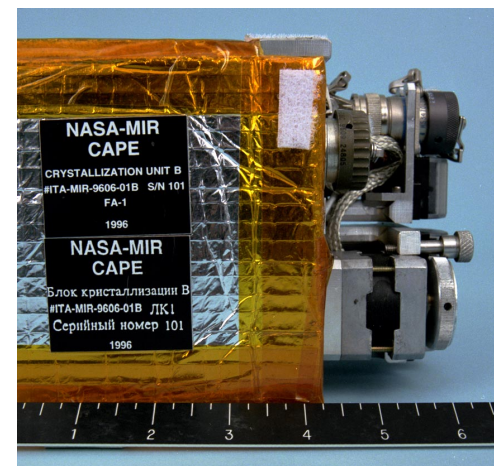

Figure MG-156 Crystallization Unit B Labels S97-18298

**CRYSTALLIZATION UNIT A**

P/N: ITA-MIR-9606-01A  
 Qty: 1  
 Mass: 7.34 kg  
 Power: 0  
 x,y,z: 16 X13 X 37.6 cm

**CRYSTALLIZATION UNIT B**

P/N: ITA-MIR-9606-01B  
 Qty: 1  
 Mass: 7.34 kg  
 Power: 0  
 x,y,z: 15.7 X 13 X 37.6 cm

**MIM INTERFACE PLATE**

P/N: ITA-MIR-9606-03  
 Qty: 1  
 Mass: 1.45 kg  
 Power: 0  
 x,y,z: 36.1 X 0.3 X 42.4 cm

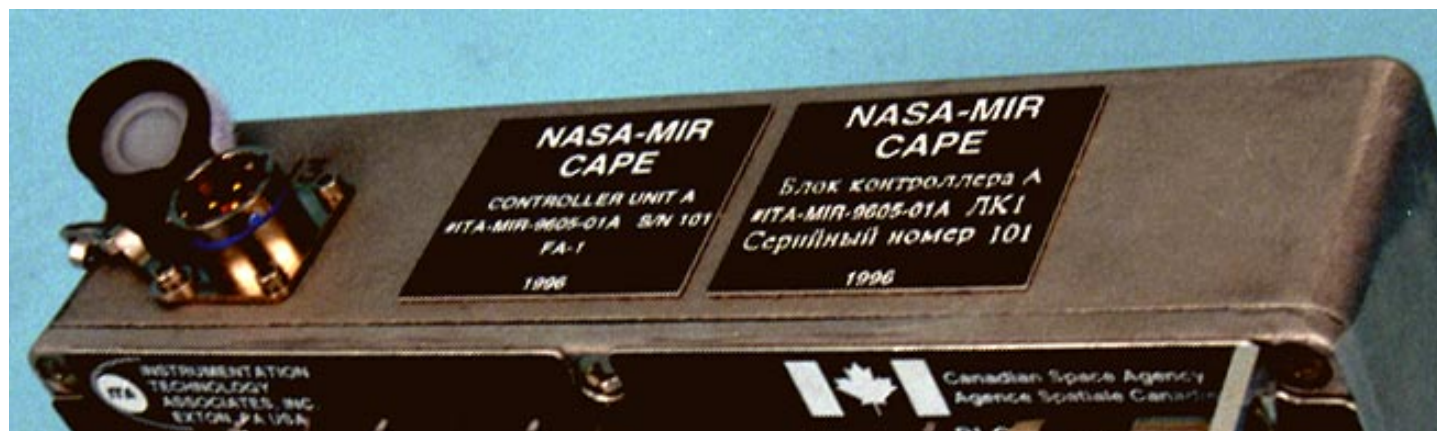

Figure MG-160 Controller Unit A Power Connector

S97-18278

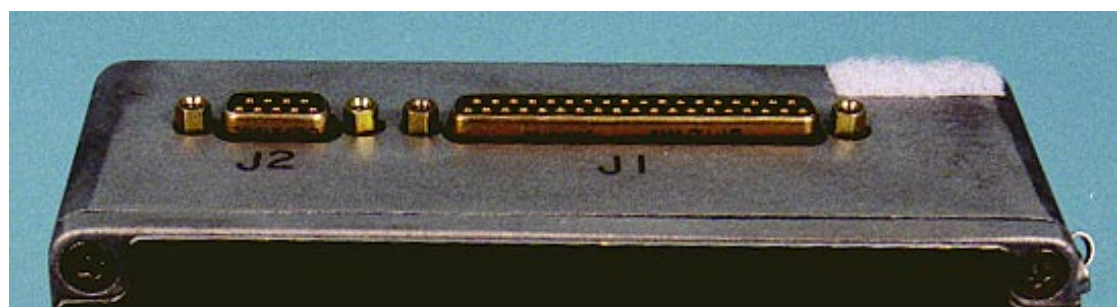

Figure MG-158 Controller Unit A Data Cable Connections

S97-18277



Figure MG-159 Controller Unit A Fuse Location

S97-18321



Figure MG-161 Controller Unit A Front Panel

S97-18279

**CONTROLLER UNIT A**

P/N: ITA-MIR-9605-01  
 Qty: 1  
 Mass: 1.79 kg  
 Power: 0  
 x,y,z: 22.3 X 16.5 X 8.1 cm





Figure MG-162 Controller Unit B Front Panel

S97-18319

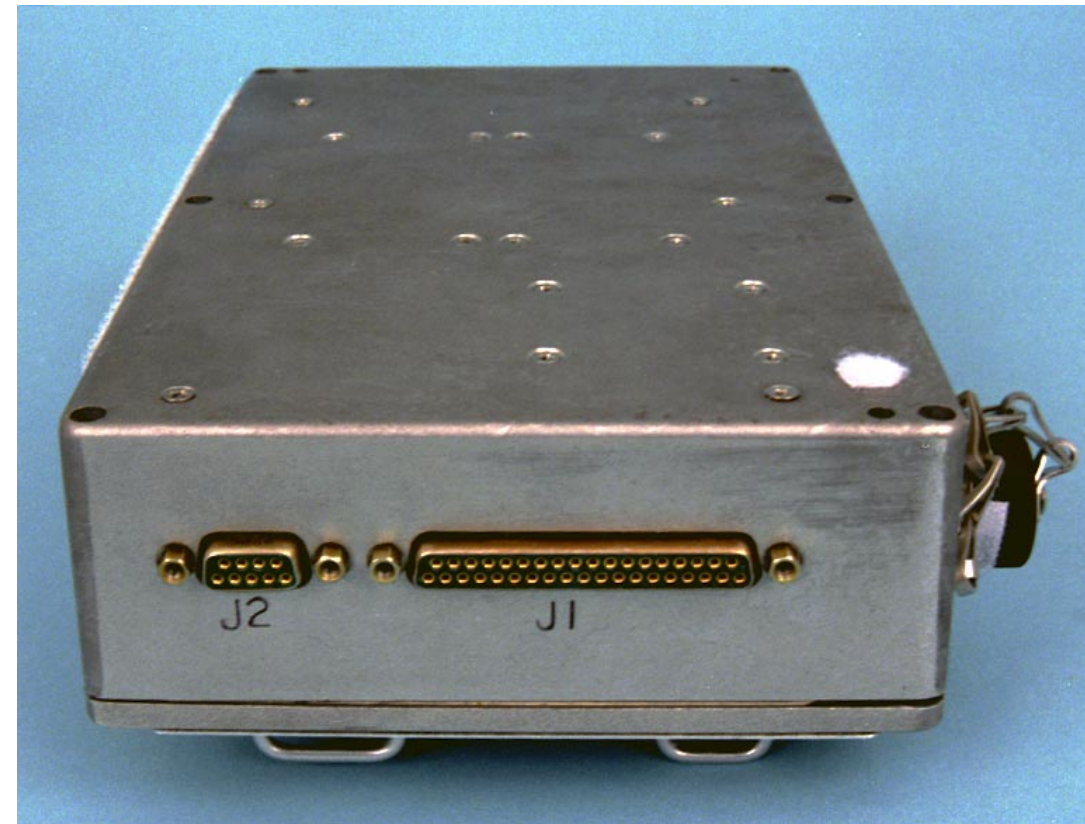

Figure MG-164 Controller Unit B Data Connections

S97-18303

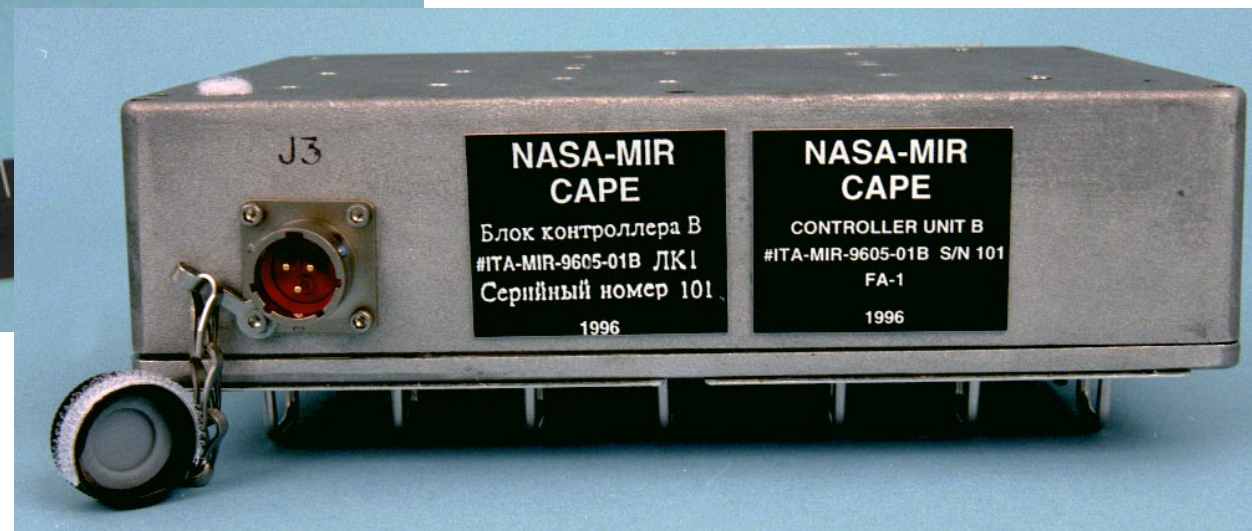

Figure MG-163 Controller Unit B Power Connector

S97-18275

**CONTROLLER UNIT B**

P/N: ITA-MIR-9605-01B  
 Qty: 1  
 Mass: 1.73 kg  
 Power: 0  
 x,y,z: 22.1 X 16.5 X 8.1 cm





S97-18302

Figure MG-167 Tape Recorder B

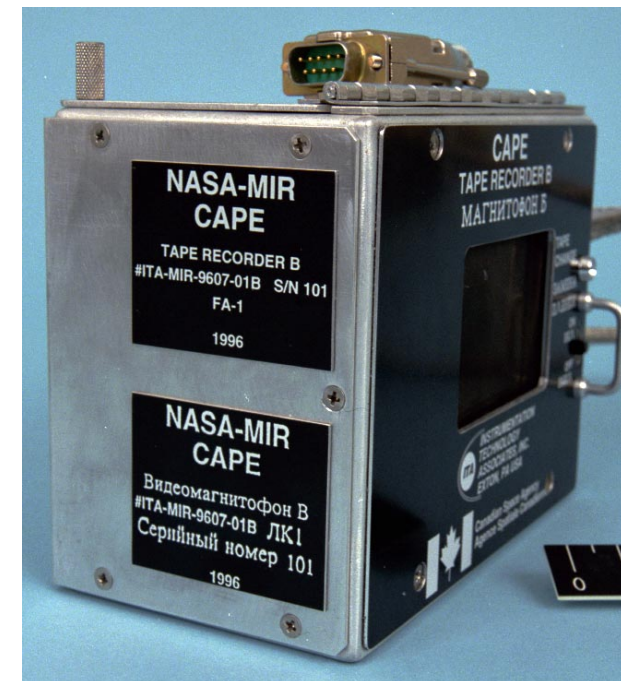

S97-18301

Figure MG-168 Tape Recorder B Labels

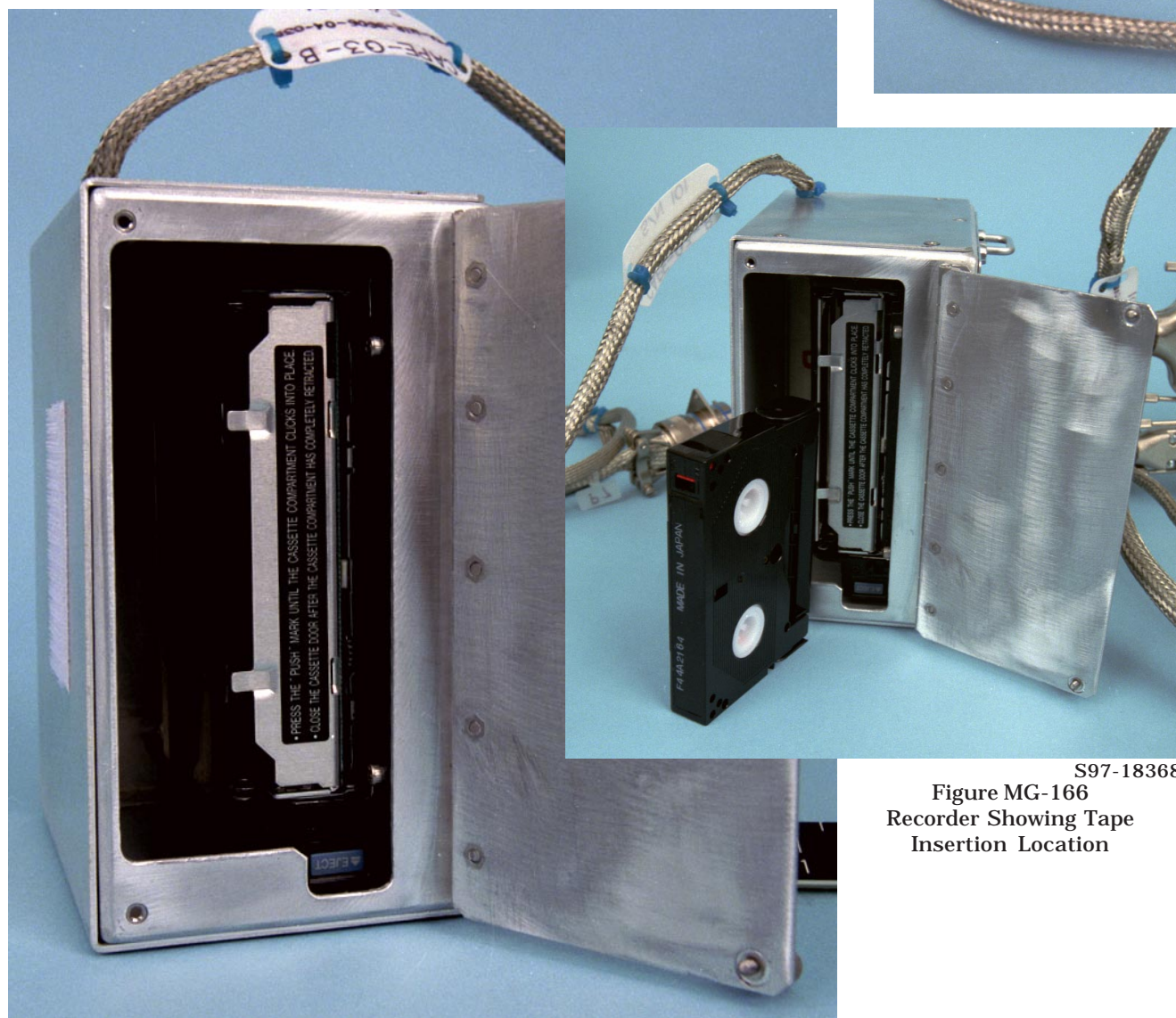

S97-18368

Figure MG-166 Recorder Showing Tape Insertion Location

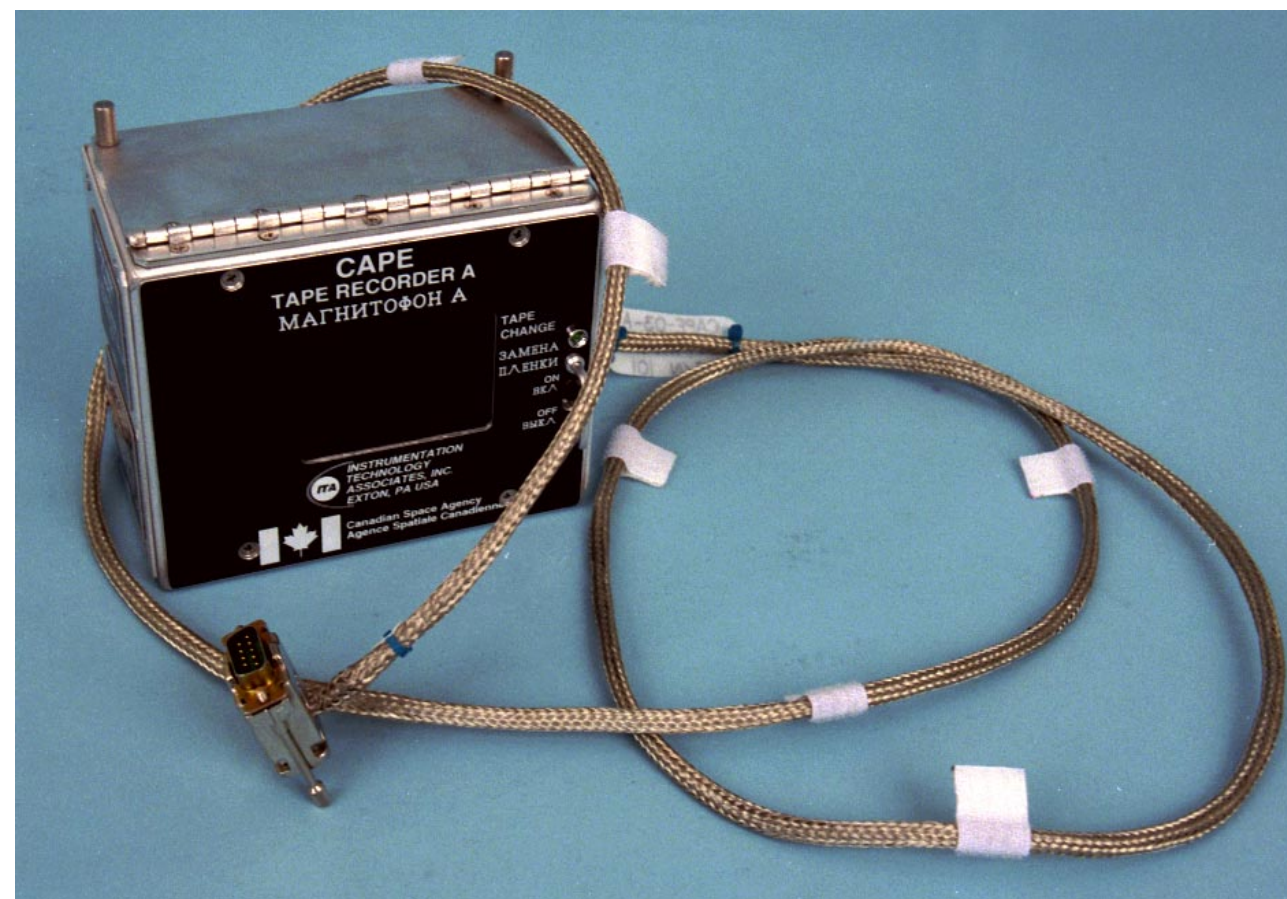

S97-18281

Figure MG-169 Tape Recorder A

**TAPE RECORDER A**

P/N: ITA-MIR-9607-01A  
 Qty: 1  
 Mass: 1.02 kg  
 Power: 0  
 x,y,z: 14.5 X 12.7 X 9.6 cm

**TAPE RECORDER B**

P/N: ITA-MIR-9607-01B  
 Qty: 1  
 Mass: 1.03 kg  
 Power: 0  
 x,y,z: 14.5 X 12.7 X 9.6 cm

Figure MG-165 Recorder, Door Open

S97-18300



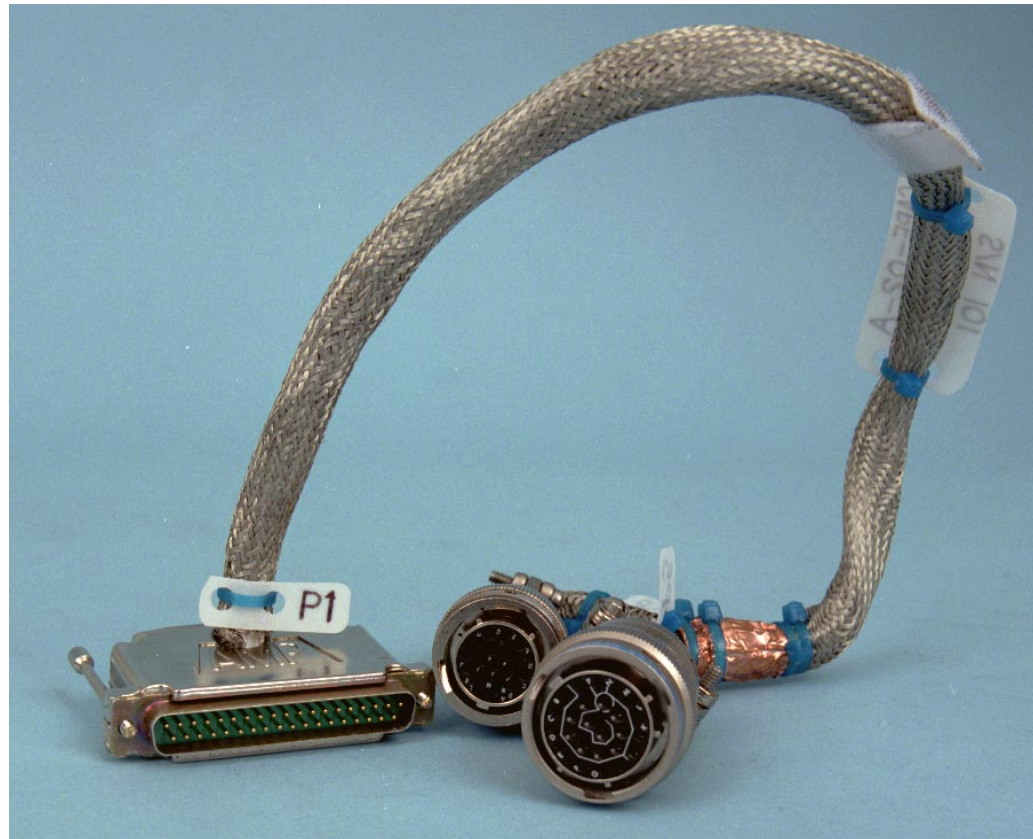

Figure MG-170 Crystallization Unit-to-Controller Cable

S97-18280



Figure MG-172 Data Disks S97-18351

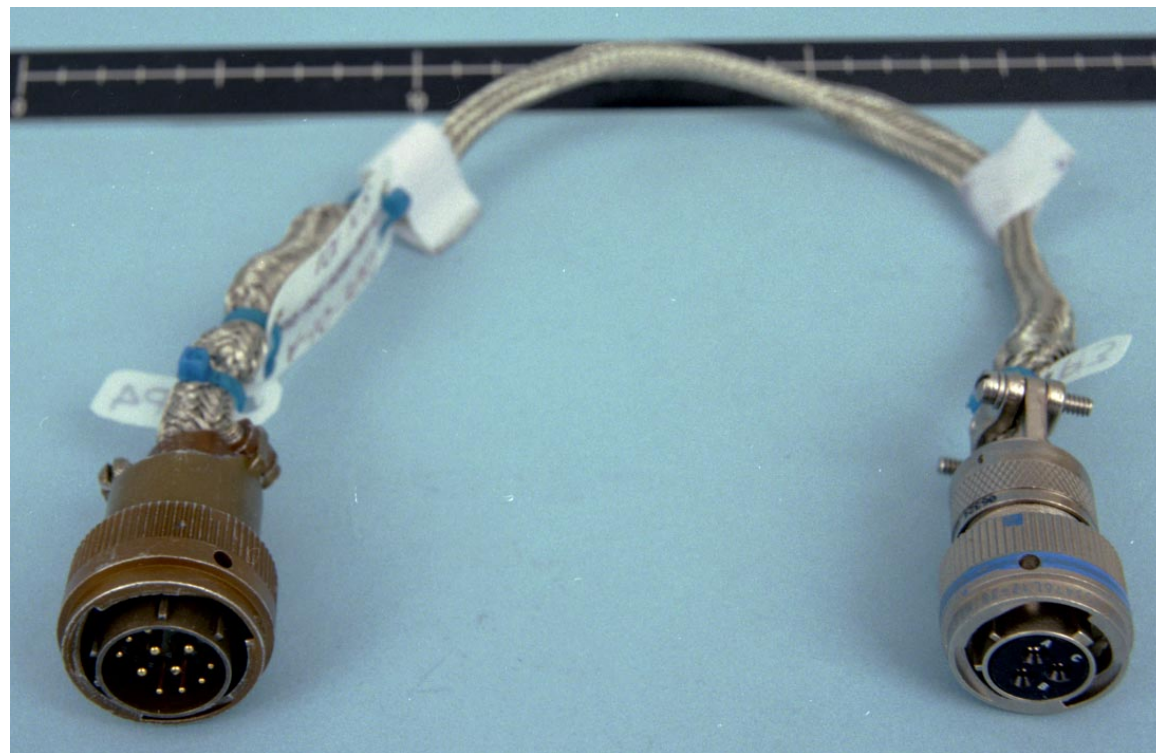

Figure MG-171 Controller-Power-Cable

S97-18320

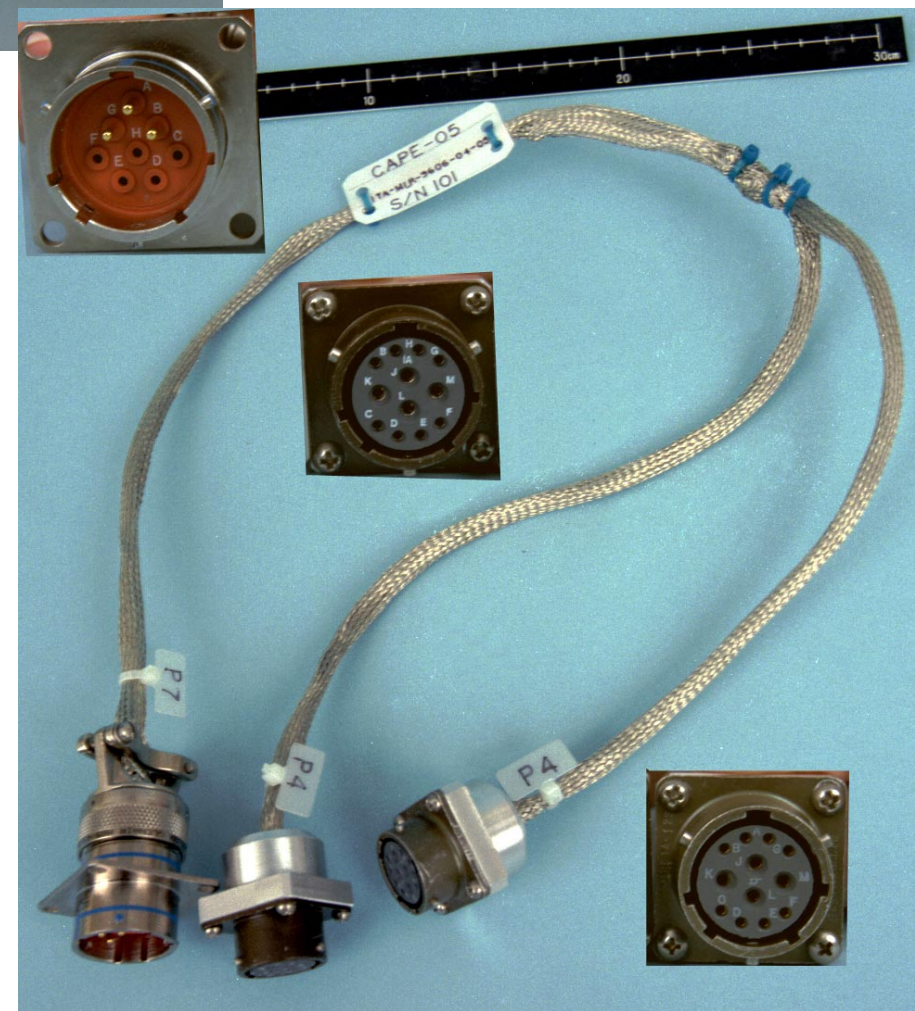

Figure MG-173 Tape Recorder-to-Controller Cable

S97-18353

**POWER CABLE A**

P/N: ITA-MIR-9606-04-01A  
 Qty: 1  
 Mass: 0.13 kg  
 Power: 0  
 x,y,z: 45.7 x 0.96 cm

**POWER CABLE B**

P/N: ITA-MIR-9606-04-01B  
 Qty: 1  
 Mass: 0.12 kg  
 Power: 0  
 x,y,z: 38.1 x 0.55 cm

**OPTICAL DISK**

P/N: MIMOD-002  
 Qty: 4  
 Mass: 0.17 kg  
 Power: 0  
 x,y,z: 13.4 x 1.1 x 15.3 cm

**CONTINGENCY POWER CABLE**

P/N: ITA-MIR-9606-04-04  
 Qty: 1  
 Mass: 0.23 kg  
 Power: 0  
 x,y,z: 79 x 0.54 cm

**CONTROLLER CABLE A**

P/N: ITA-MIR-9606-04-02A  
 Qty: 1  
 Mass: 0.33 kg  
 Power: 0  
 x,y,z: 49 x 1.2 cm

**CONTROLLER CABLE B**

P/N: ITA-MIR-9606-04-02B  
 Qty: 1  
 Mass: 0.12 kg  
 Power: 00.  
 x,y,z: 38.1 x 0.55 cm





# COLLOIDAL GELATION (CGEL)

## HARDWARE DESCRIPTION

This investigation consists of one CGEL module, seven vial holders, and a small power control module with associated cables. On orbit, the vial holder, and O-ring sealed acrylic box containing four fused silica vials, will be visually inspected after removal from stowage, transported, and placed in the MGBx.

The power control module with its cable will be unstowed and attached to the MGBx via Velcro. The power control module cable will then be connected to its respective MGBx front panel interface. Inside the MGBx, the CGEL module power cable is connected to the ICP. A vial will then be removed from the transparent vial holder and mounted with the vial collet of the CGEL module.

The laser light for sample vial investigation will be transmitted via fiber optics from the Laser/Detector subassembly within the CGEL module. A 30 mW laser diode will provide an attenuated output of 15 mW for projection through the sample vial under investigation.

The four sample vials in each vial holder will contain various concentrations of PMMA hard spheres (.5 microns) in a decaline and tetraline solvent medium. Each of the four sample vials will be viewed in turn with the laser light. The laser lighted vial under investigation will be video recorded through a diffused screen in the wall of the CGEL module. A detection sensor in the fiber-optics return path to the Laser/Detector subassembly will provide data for Payload and General Support Computer (PGSC) interpretation of the light scattered by the hard spheres in the sample vials.

The following Hardware list will be covered in detail in the following pages and comprises all flight components used in the CGEL experiment.

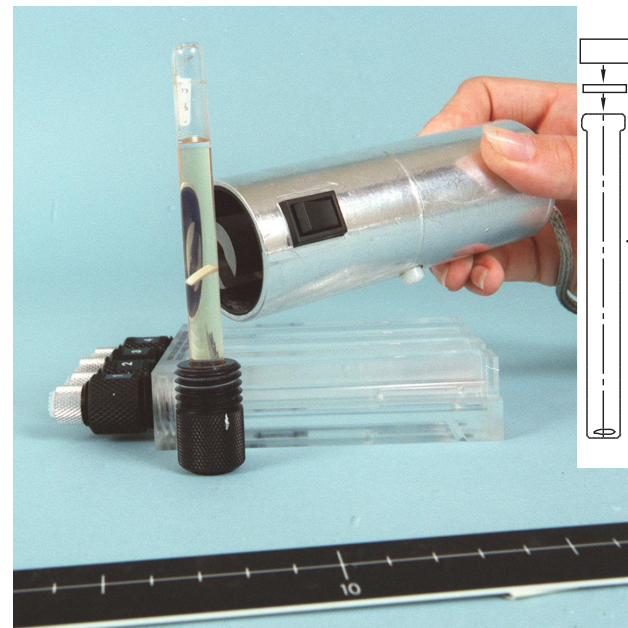

S96-18540

Figure MG-175 Sample Cell with Magnetic Stir Bar

- Sample Cells
- Experiment Module
- Power Control Box
- Cabling
- Computer Hardware
- Software
- Photo Fixture
- Flight Spares
- Magnetic Stirrer

## SAMPLE CELLS

The sample cells provide the primary containment of sample materials. Twenty-eight samples will be flown. Each Supracil cell is 10mm O.D. by 8 mm 1.0 by 95 mm long. The opening is sealed with a Teflon covered, silicon rubber septum under a crimped aluminum cap.

There are seven sample cell holders containing four samples each. The sample cell holders provide a second level of sample containment for operations outside of MGBx.

The holders are made of Polycarbonate and the caps are integrated with sample cells. Vertical grooves are for a horseshoe magnet during homogenization.

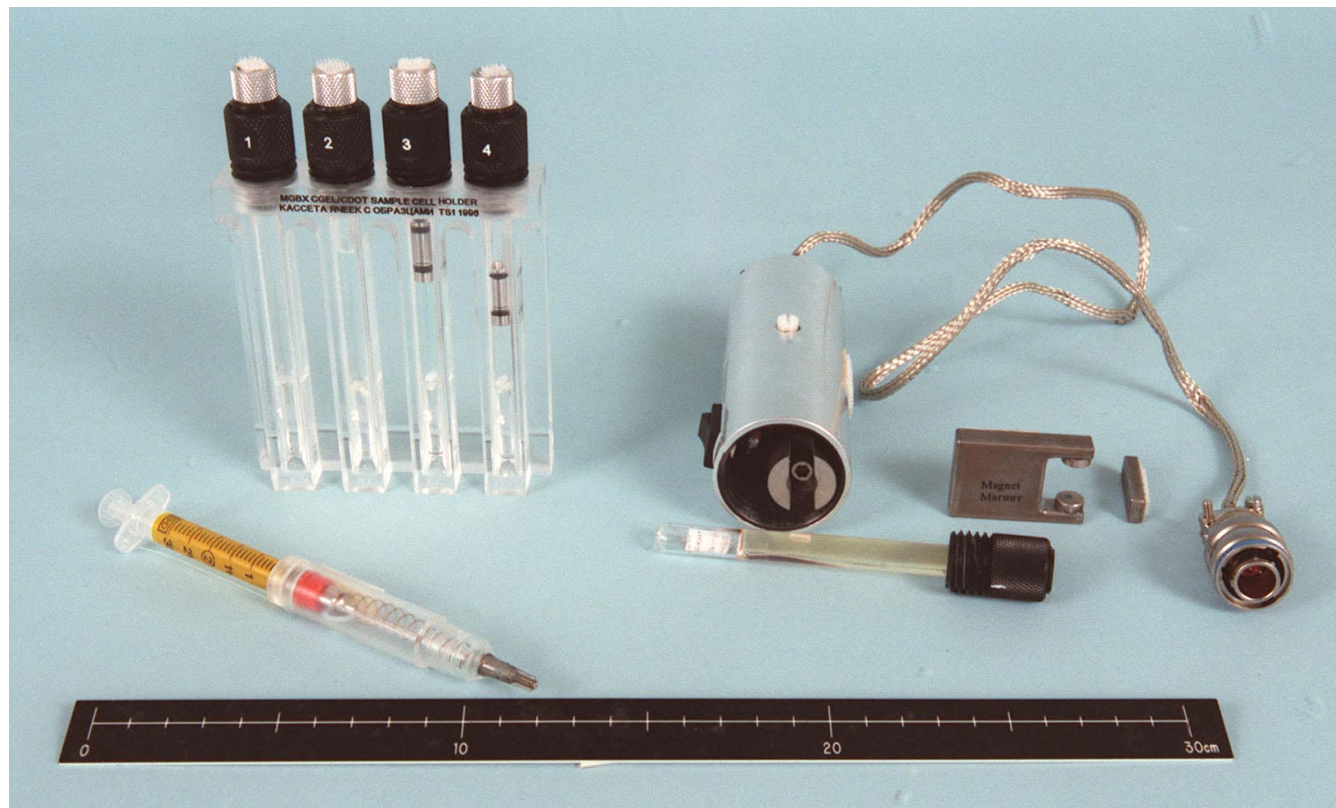

S96-18538

Figure MG-174 Sample Cells and Related Equipment

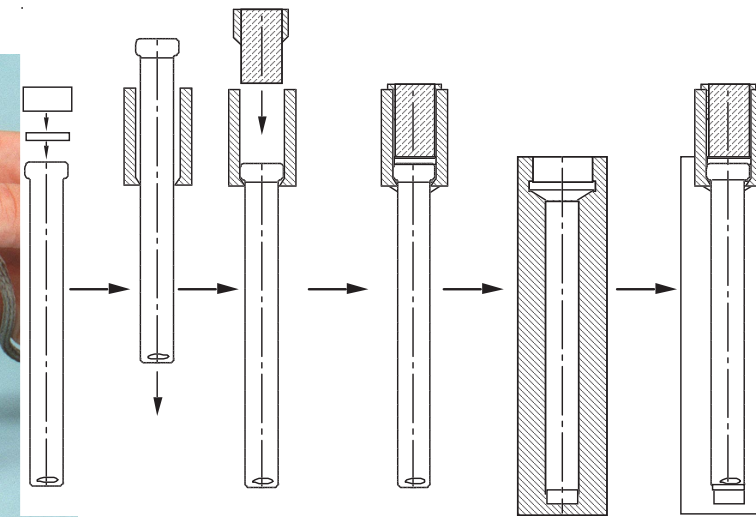

Figure MG-176 Sample Cell Assembly



S96-18541

Figure MG-177 Demonstration of Sample Cell Injection



Colloidal Gelation

**Principal Investigators:**  
 Dave Weitz  
 University of Pennsylvania  
 Professor of Physics  
 (215)898-7522

Peter Pusey, FRS  
 University of Edinburgh-Scotland  
 44-31-650-5255

## EXPERIMENT MODULE

The experiment module consists of light-scattering, translation, and oscillation hardware which is described below.

### Light-Scattering Hardware

The light-scattering hardware consists of:

#### Source/Detector Module (SDM)

The SDM combines laser light source and detector into one compact black box. The laser light source is a 30 mW, 780 nm laser diode pigtailed to a fiber-optic cable. It delivers approximately 15 mW at the SDM fiber-optic bulkhead. The detector is a third generation Avalanche Photodiode (APD). The output is digital pulses proportional to photons detected.

The detector is passively cooled and the +5 V power is conditioned by CGEL Power/Control Box (PCBx) from +24 MGBx supply.

### Fiber-Optic Cables

The experiment module contains two fiber-optic cables. The launching fiber delivers light from SDM laser diode to the focusing lens. The pickup fiber collects light scattered at 90° from sample cell to APD. The cables are preintegrated into the experiment module but can be changed out if damaged. The monomode polarization preserving fibers are terminated with keyed FC/PC connectors.

### Focusing Lens

The focusing lens focuses light from the launching fiber to a 50 micron spot at the center of the sample cell. Approximately 7.5 mW of the power exits the lens into the sample cell.

### 90° Scattering Pickup

The 90° Scattering Pick-up is a fiber-optic pickup for single-angle dynamic light-scattering measurements. The design alleviates needs for high-precision alignment.

### Bragg Screen

The Bragg Screen is a cylindrical screen used to collect video images of Bragg scattering from samples. The inside of the screen is lined with translucent material to form a transmission screen. The sample cell acts as a cylindrical lens in that all light scattered at the same angle is focused to a line on the screen and the screen is located at effective focal length (3r) of sample cell/optical sleeve combination.

### Optical Sleeve

The optical sleeve increases the cylindrical lensing effect of a sample cell. It increases the image distance from cell to screen that improves screen resolution.

### Safety Features

The beam Stop terminates the main beam via an angled, blackened hole in the beam path beneath the sample cell.

Side panels prevent stray specular reflection off of cell and optical sleeve surfaces. The panels are black anodized aluminum panel on both sides of the Bragg Screen.

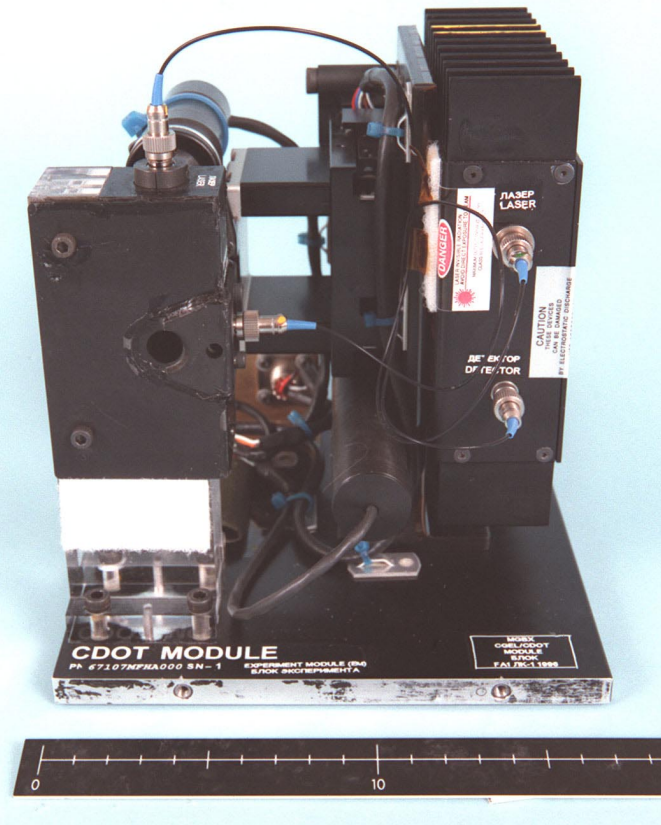

Figure MG-178  
Experiment Control Module Front

S96-18529

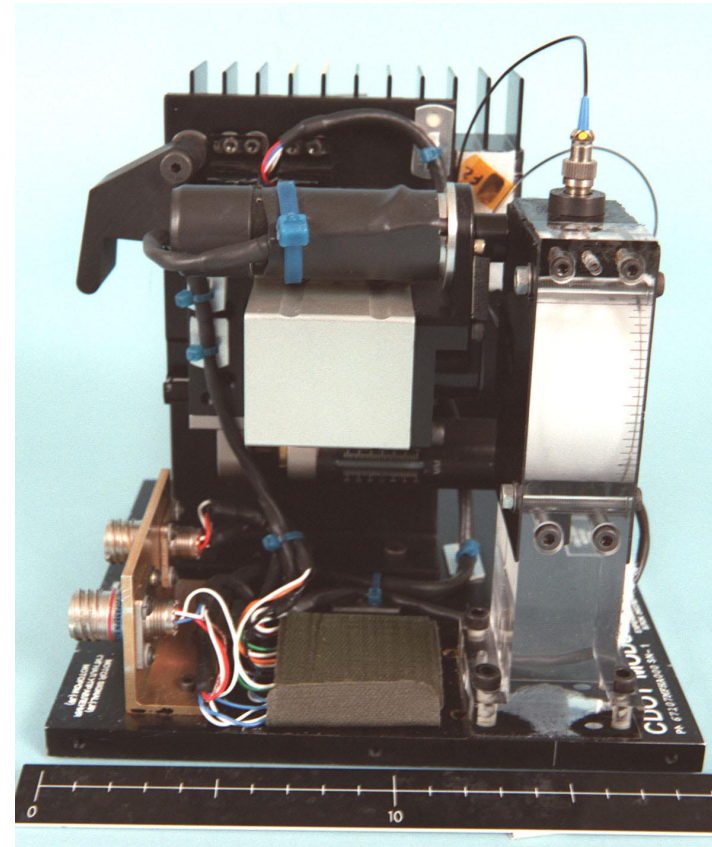

Figure MG-179  
Experiment Control Module Side View with Lever Down

S96-18531

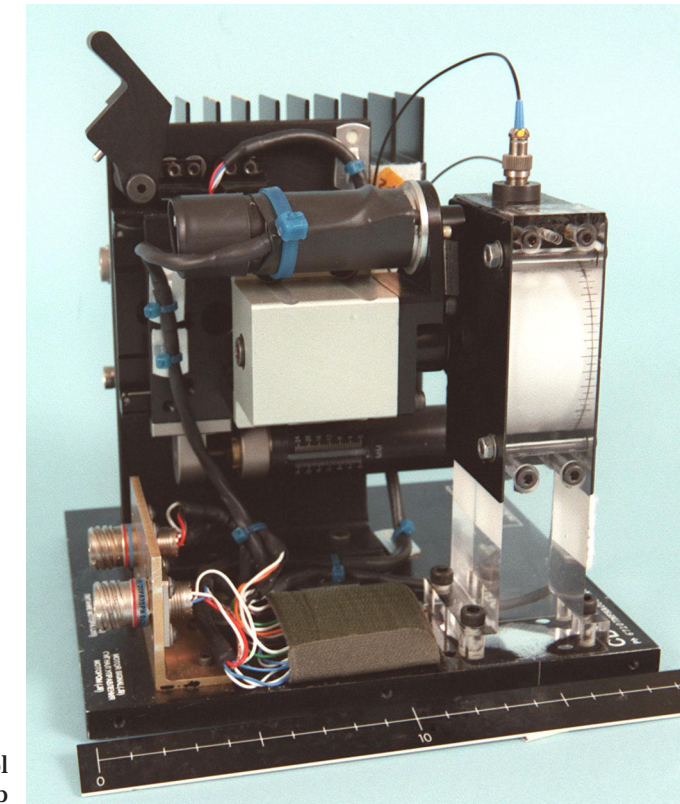

Figure MG-180  
Experiment Control Module Side View with Lever Up

S96-18532

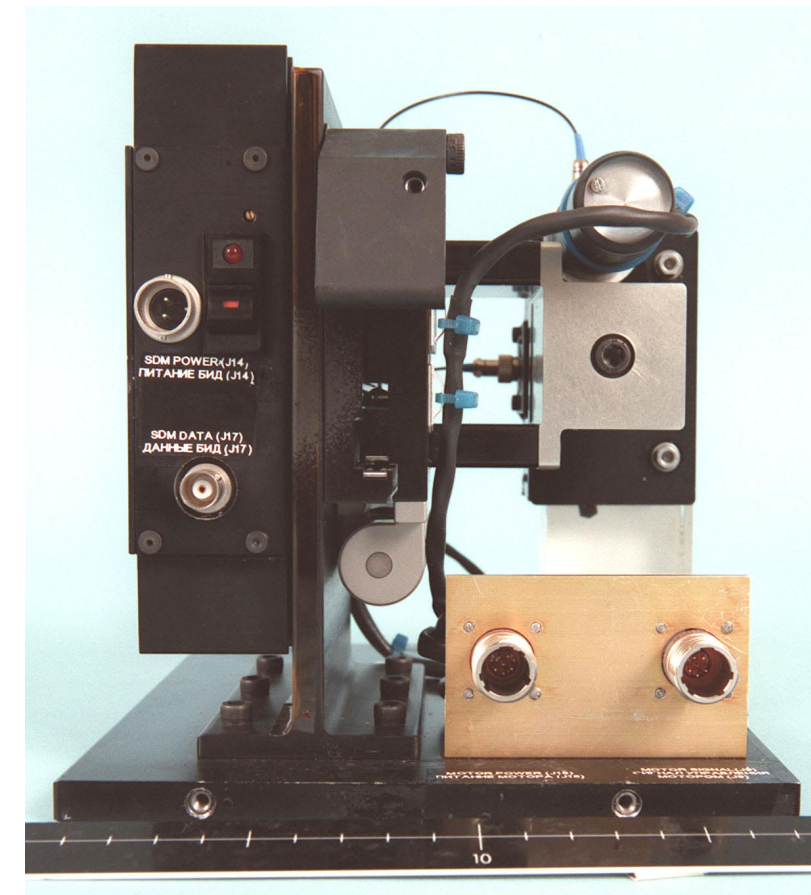

Figure MG-181  
Experiment Control Module Back

S96-18533



## Translation Hardware

The translation hardware serves the purpose in sample collection of holding the sample cells in place. The translation stage provides an interface with the stationary components. The translation motor is a DC linear actuator that controls translation. It has two rates of travel: 1) slow rate (approximately 50 microns/sec = .002"/sec) for data gathering, and 2) fast rate (approximately 700 microns/sec = .03"/sec) for quick return.

The Hall Effect Sensors function as limit switches that allow approximately 2 cm (3/4") of travel.

## Oscillation Hardware

The oscillation hardware is capable of oscillating cells at frequencies between approximately 8 and 8 Hz. It consists of an oscillation motor and an oscillation arm. The motor is a DC motor with eccentric hub on shaft. The oscillation arm moves in a constant amplitude of 2° are about the centerline of the cell.

## PCBX

The PCBx is attached to the right side of the MGBx exterior. The PCBx provides experiment circuit protection, +24 V to +5 V power conversion for SDM, and partial motor control functions for translation and oscillator motors. The PCBx is passively cooled.

## EXPERIMENT CABLING

The CGEL experiment uses seven cables for routing power, motor signals, and experiment data. The cables are listed below with their function.

- Power
  - Internal Power Cable (W1)
  - External Power Cable (W5)
  - Docking Station Power Cable (W6)
  - DC Power Supply Cable (W7)
- Motor Signals
  - External Signal Cable (W4)
  - Airlock Cable Assembly (W2)
- Experiment Data
  - Airlock Cable Assembly (W2)
  - External Data Cable (W3)

## COMPUTER HARDWARE

The CGEL experiment uses the MIPS. The experiment also uses 2 experiment-specific pieces of hardware: 1) The Correlator Card (Brookhaven Instruments BI-9000 AT) is a digital correlator on a single ISA board (PC computer) 2) The Motor Controlled Card (Quatech SAC-12) that is a commercial card with a half ISA slot.

## SOFTWARE

The software is based on the commercial BI-9000 correlator software with modifications to control experiment motors and to enhance user interface. The software requires minimal crew interaction. It utilizes predefined control files to define experiment parameters and to store data.

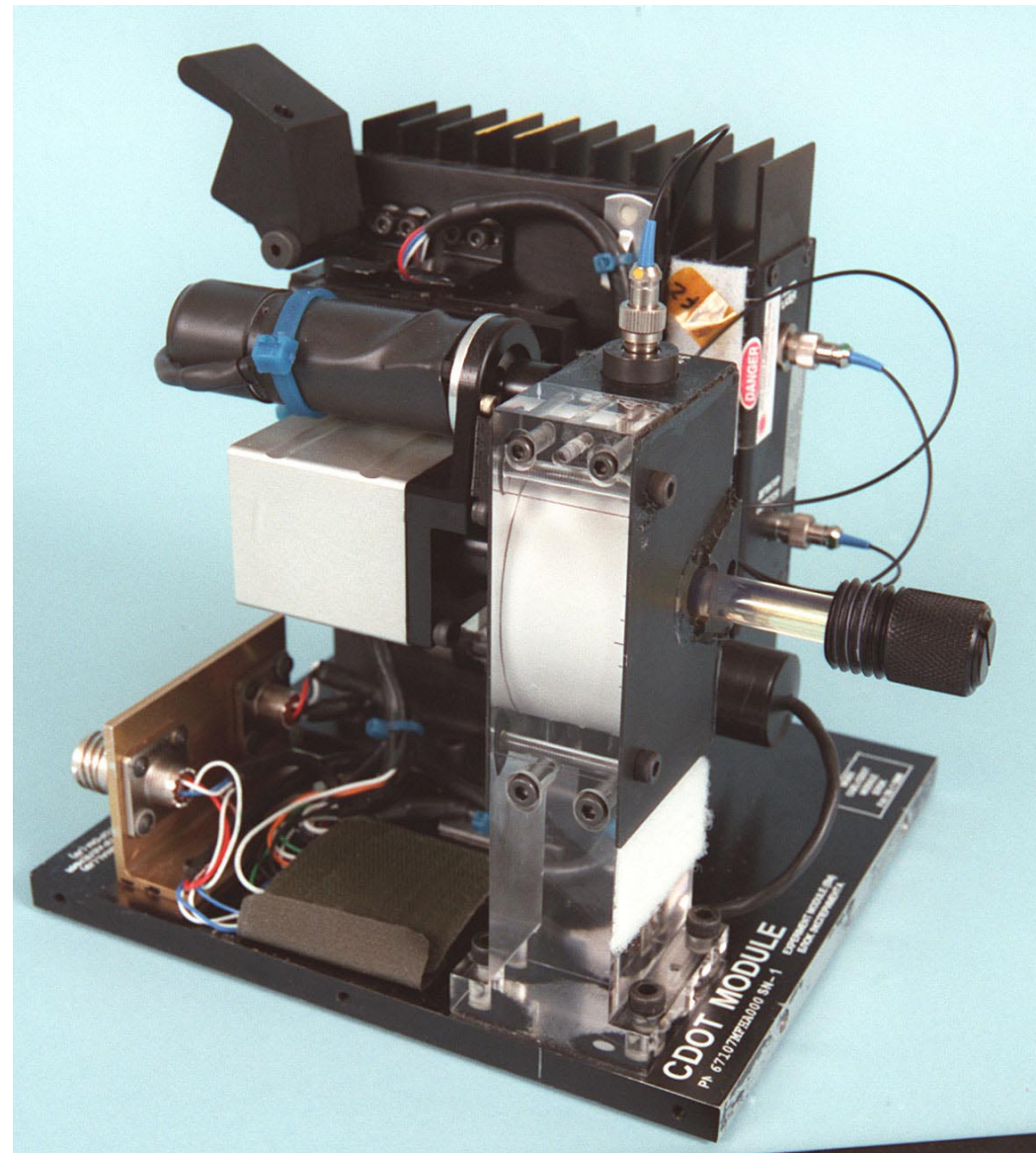

Figure MG-182 Module With Sample Cell Inserted

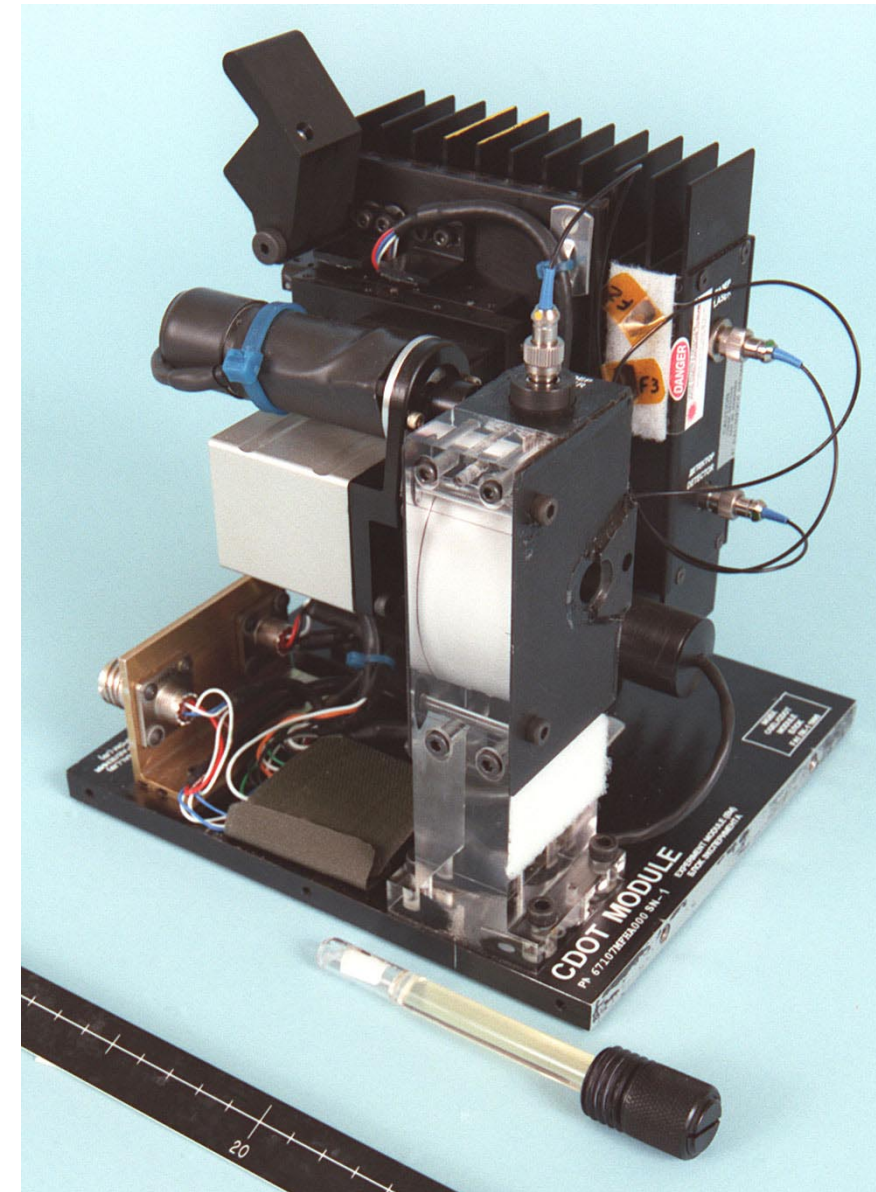

Figure MG-183 Module with Sample Cell Aside S96-18536

## FLIGHT SPARES

The following spares for the CGEL experiment will be flown:

- Source/detector module
- Spare IBM ThinkPad
- Spare Docking Station Containing:
  - Correlator Card
  - Motor Controller Card
- Fiber-Optic Cable
  - launching and pickup fibers are interchangeable \*

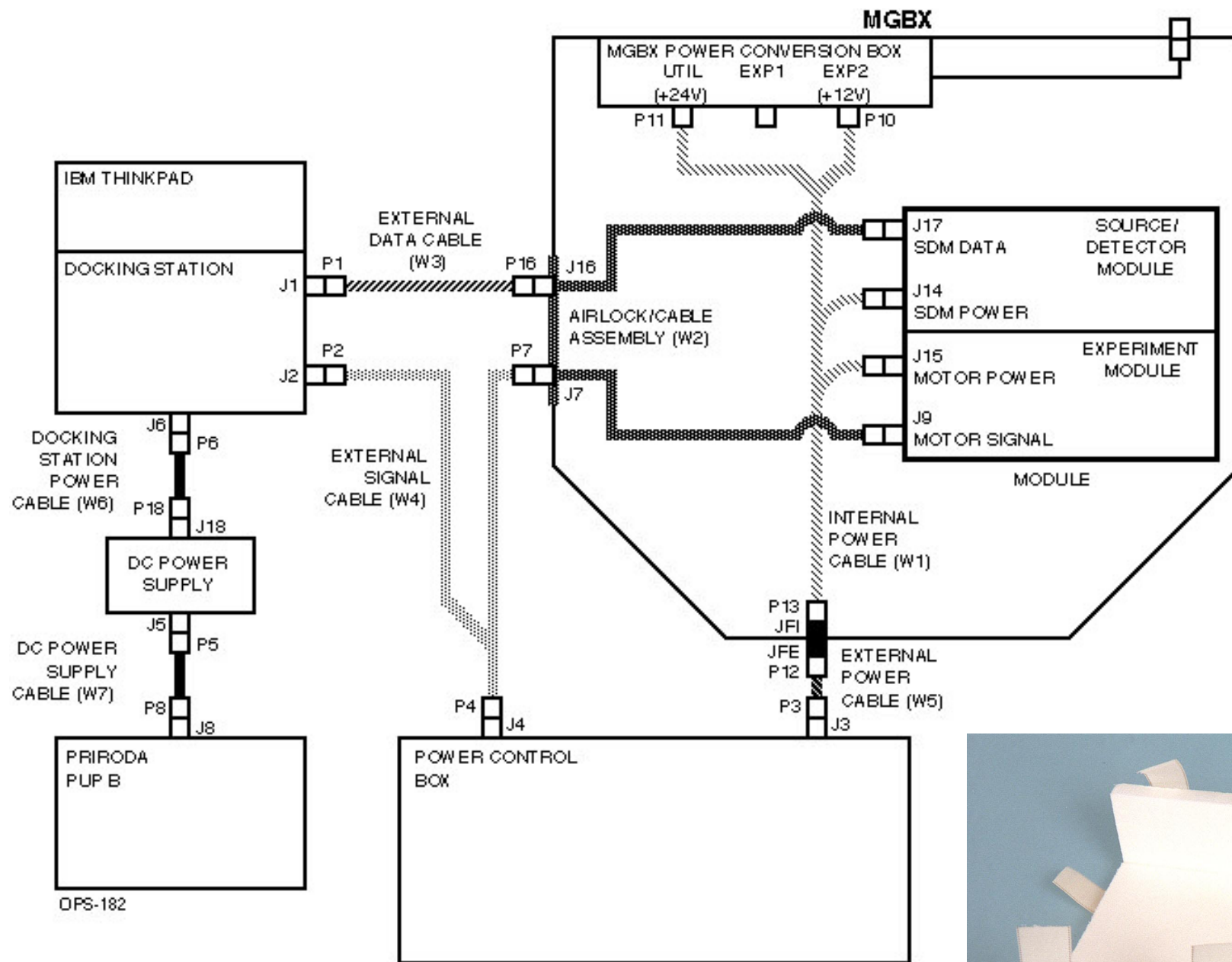

Figure MG-184 Electrical Block Diagram

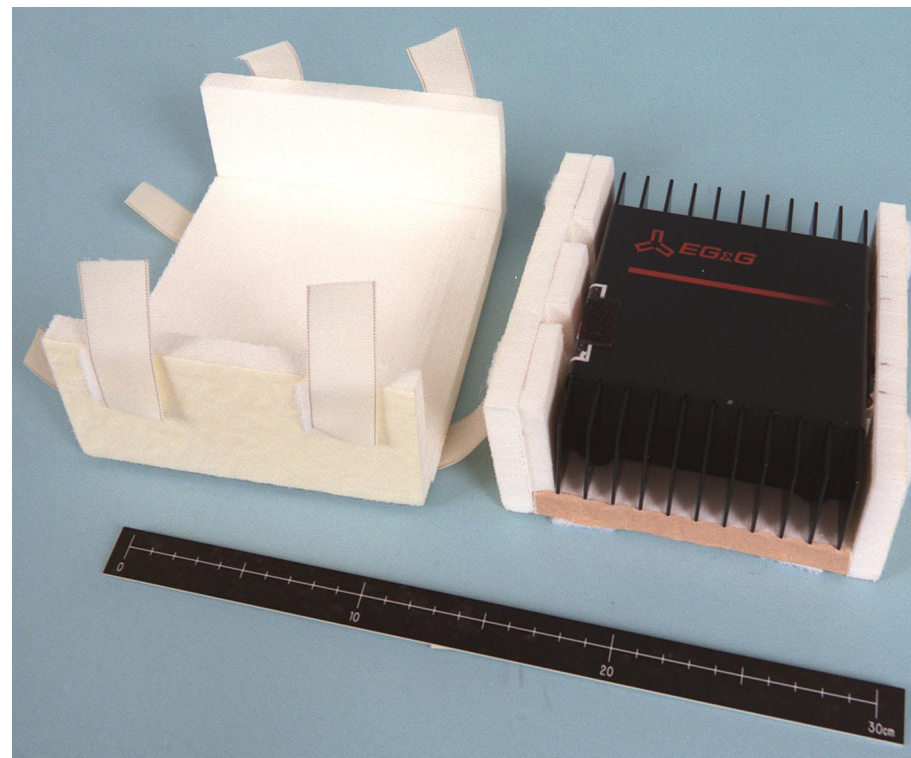

Figure MG-185 Laser Backup

S96-18450



Figure MG-186 Laser Backup in Package

S96-18449





Figure MG-187 Power Control Box Cable Connectors

S96-18490



Figure MG-189 Power Control Box Signal Lights

S96-18489

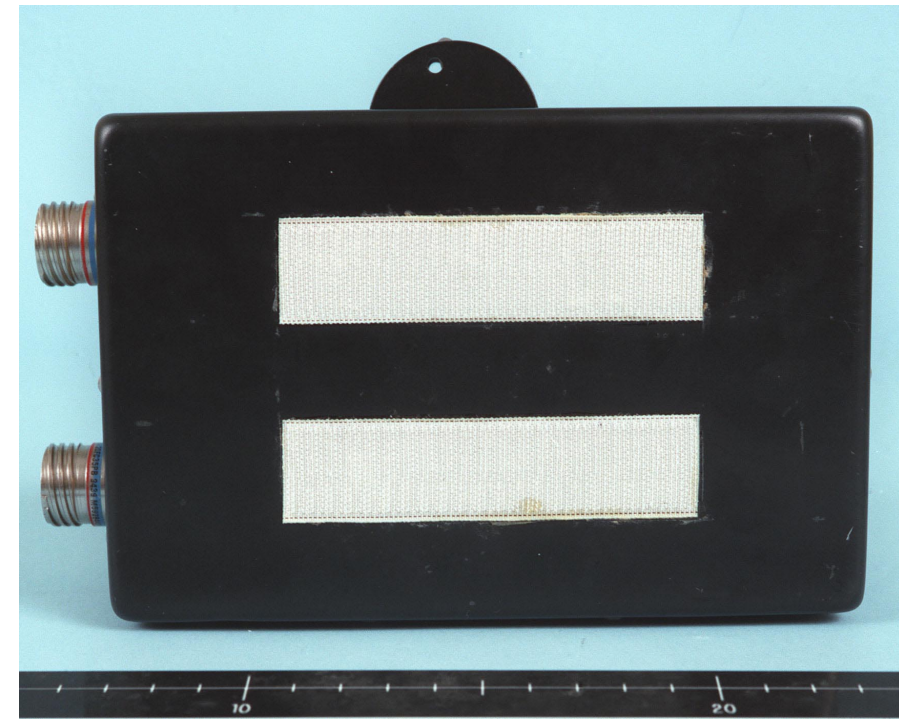

Figure MG-190 Power Control Box Velcro Locations

S96-18487

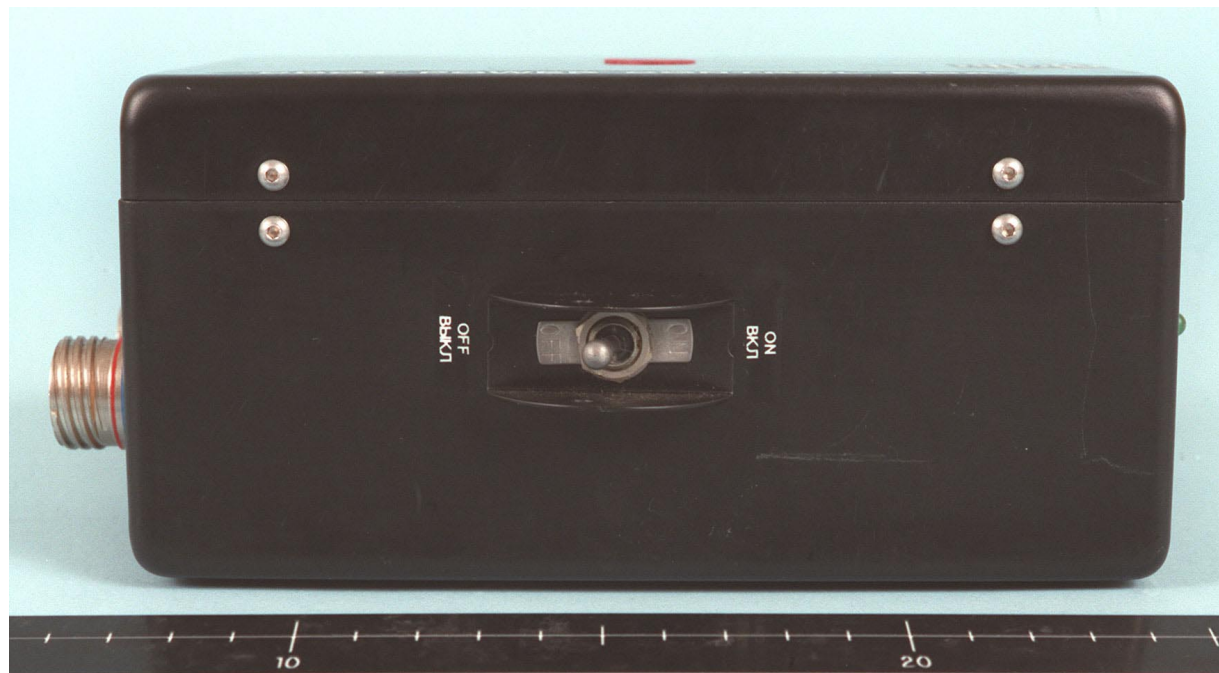

Figure MG-188 Power Control Box Switch

S96-18488



Figure MG-191 Power Control Box Top

S96-18491





Figure MG-192 External Power Cable and Connectors



Figure MG-195 External Signal Cable

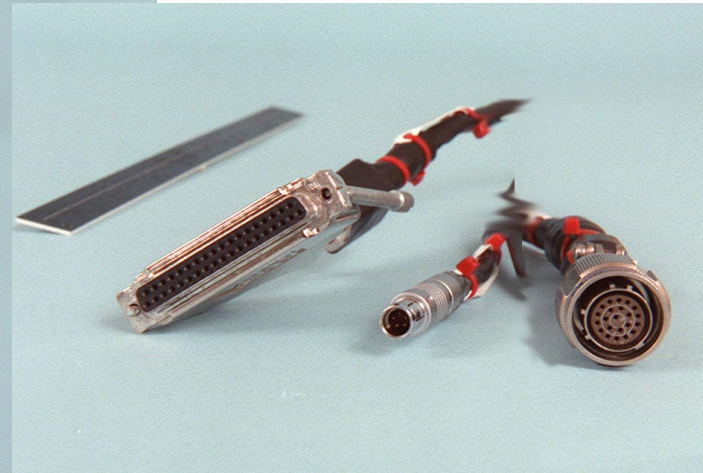

Figure MG-196 External Signal Cable Connectors

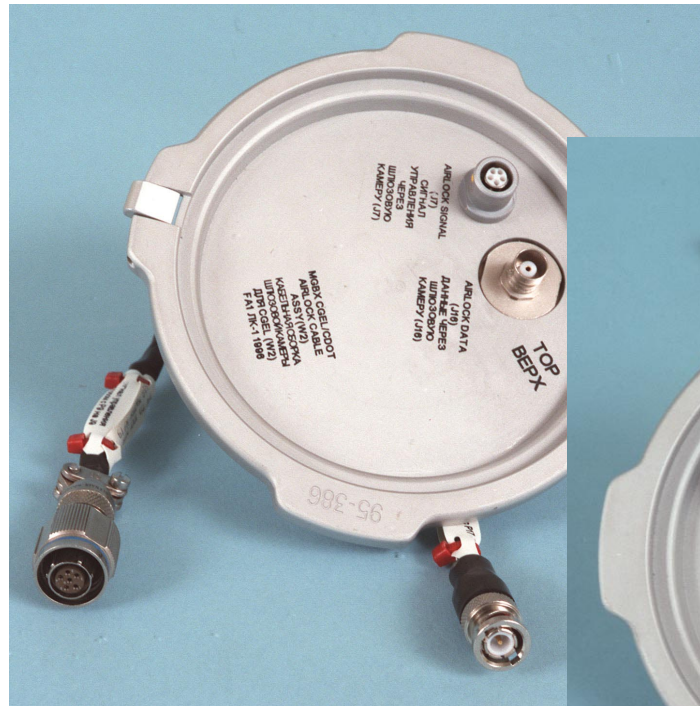

Figure MG-193 Airlock Cable Assembly



Figure MG-194 Airlock Cable Assembly Connectors

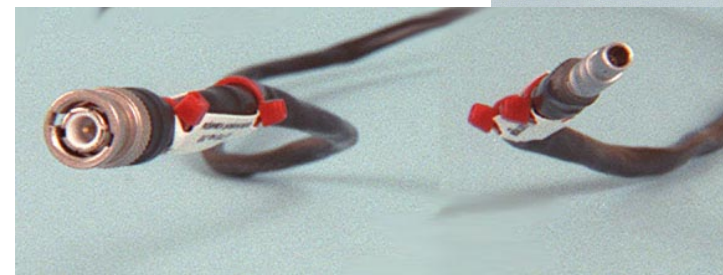

Figure MG-197 External Data Cable Connectors

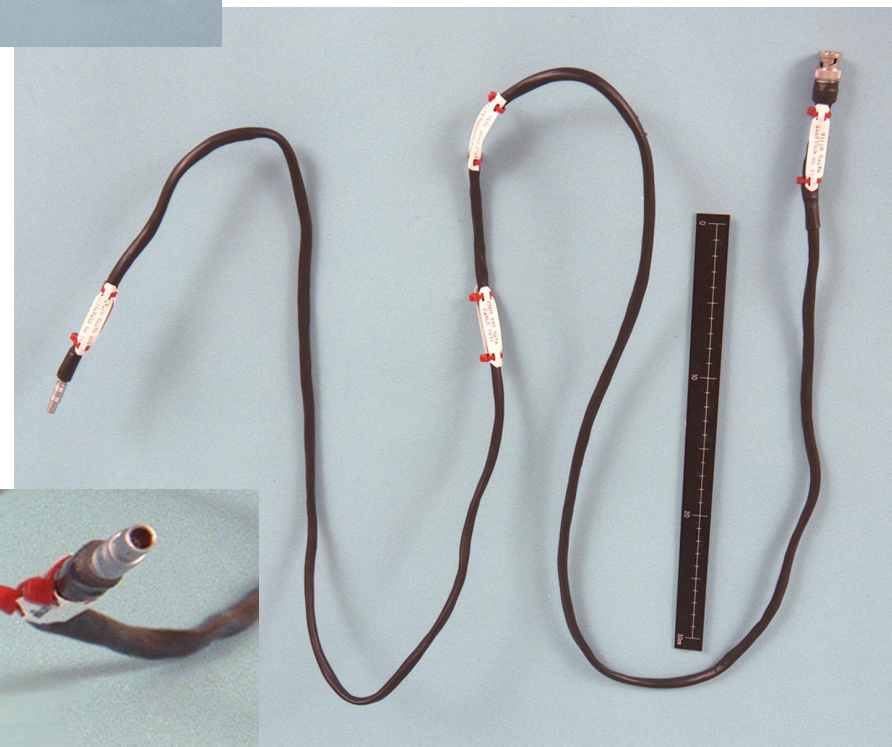

Figure MG-198 External Data Cable





S96-18482

Figure MG-199 CGEL PCMCIA Hard Drives



S96-18569

Figure MG-201 CGEL Group Picture [Except: Docking Station Power Cable (W6), DC Power Supply, and DC Power Supply Cable (W7)]



S96-18473

Figure MG-200 PLS Extension Cable



S96-18494

Figure MG-202 Automatic Magnetic Stirrer





Figure MG-203 CGEL/CDOT Kit

S96-

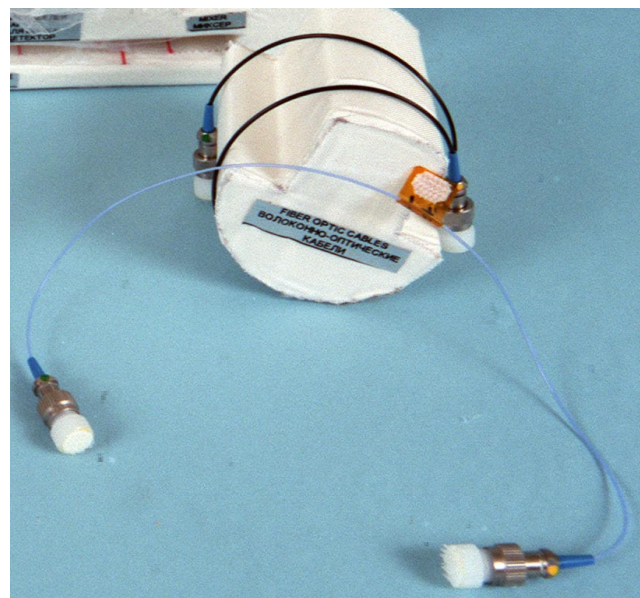

Figure MG-205 Fiber Optic Cables

S96-18483

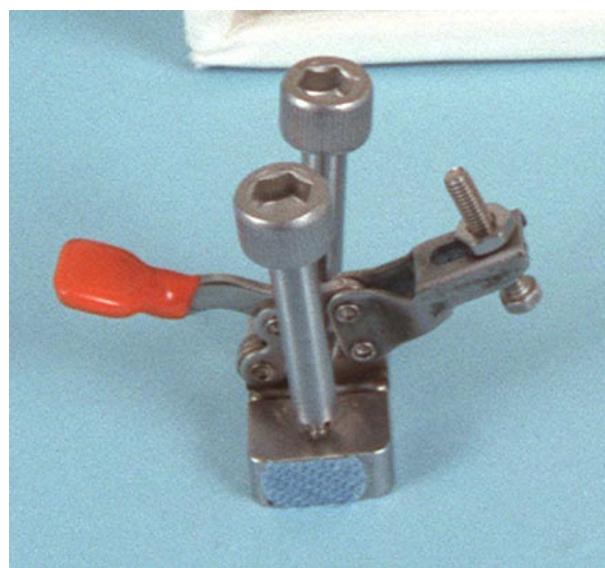

Figure MG-204 Retaining Clamp

S96-18493

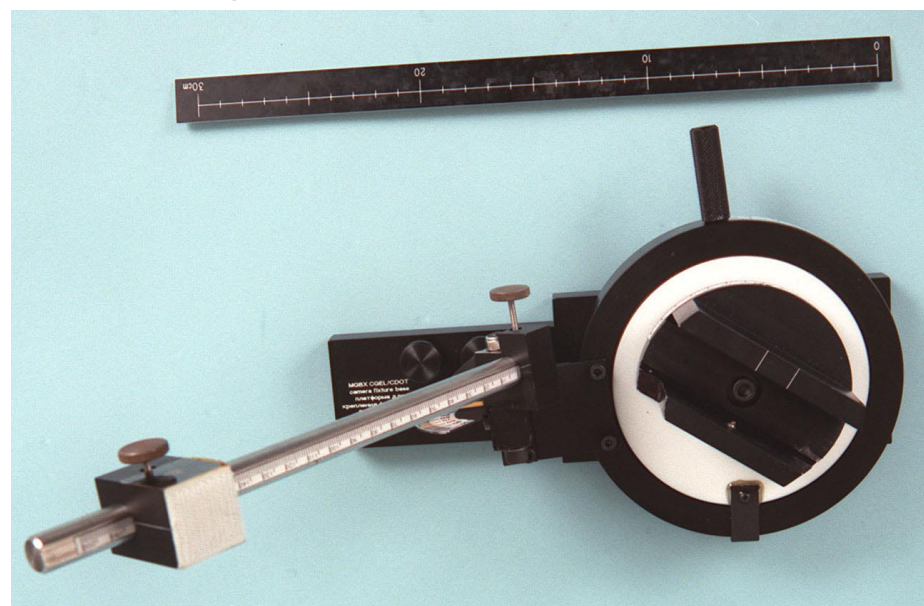

Figure MG-206 CGEL Camera Base Top View

S96-18492

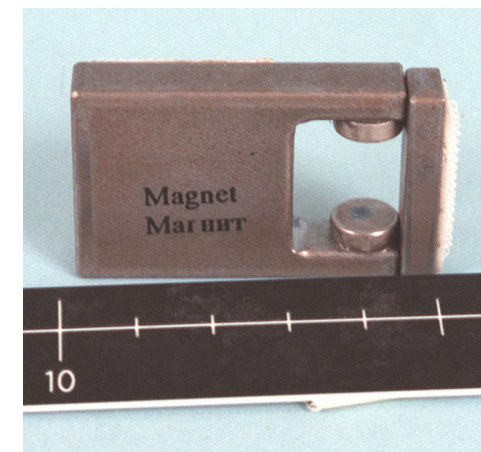

Figure MG-207 Manual Magnetic Stirrer

S96-18495

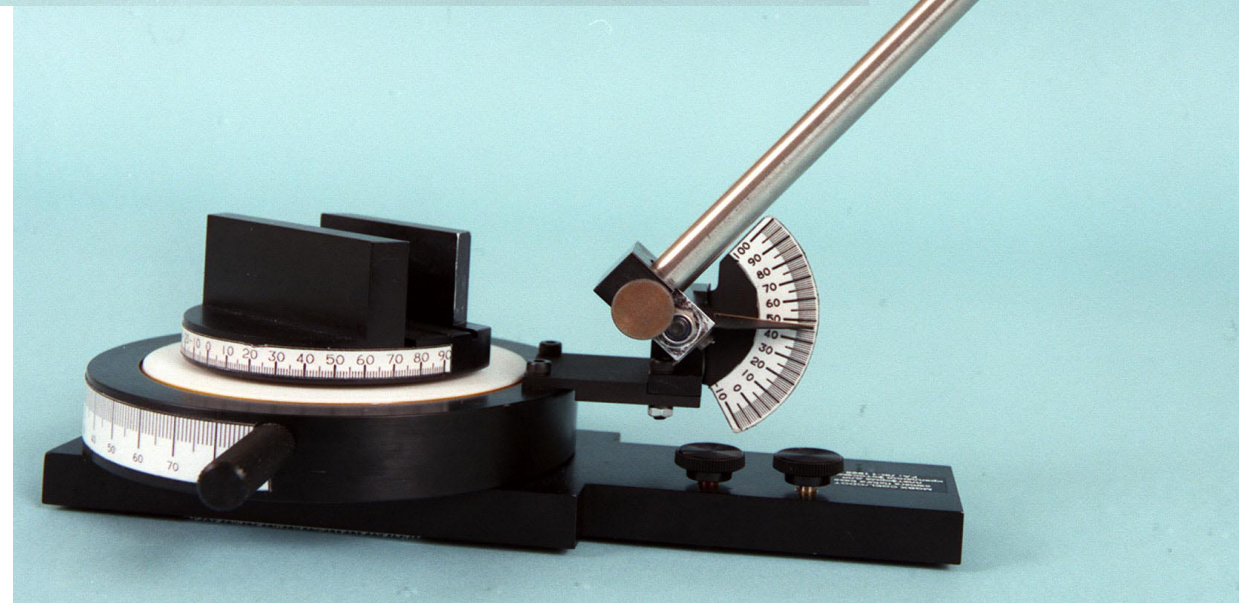
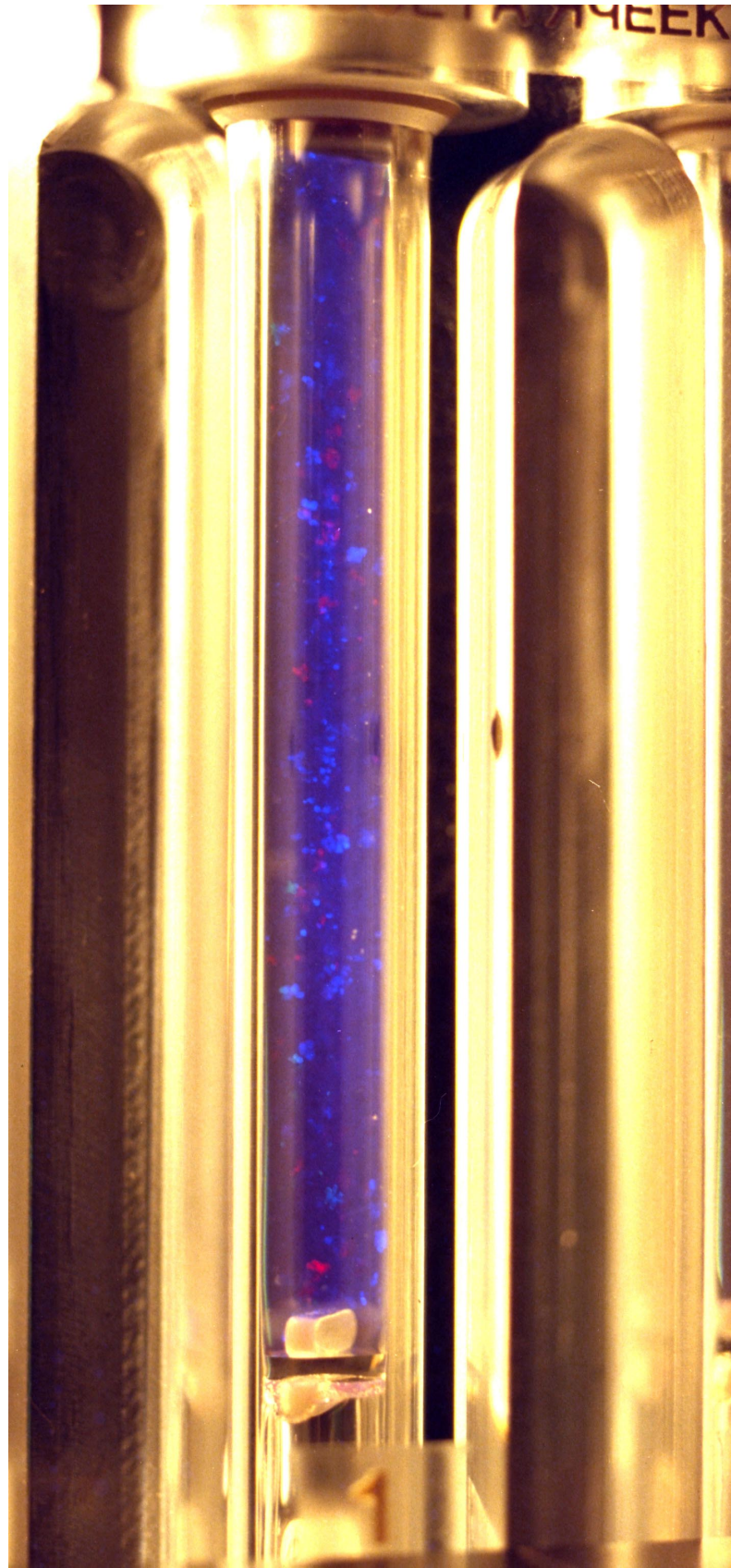

Figure MG-208 CGEL Camera Base Side View

S96-18493







NASA5-302-009  
Figure MG-209 CGEL Tube 1 Showing Crystals

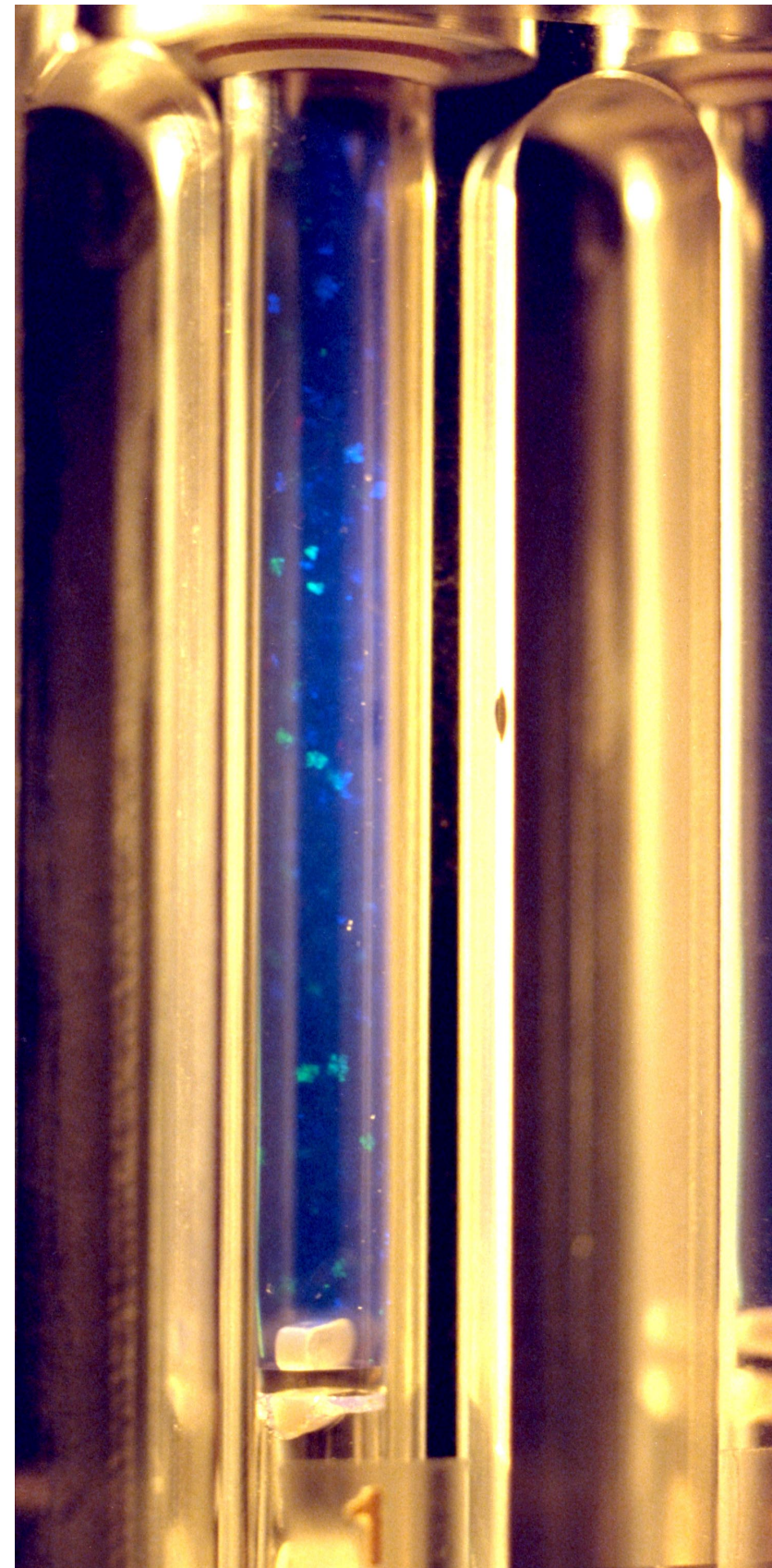

NASA5-312-11  
Figure MG-210 CGEL Tube 1 Showing Crystals

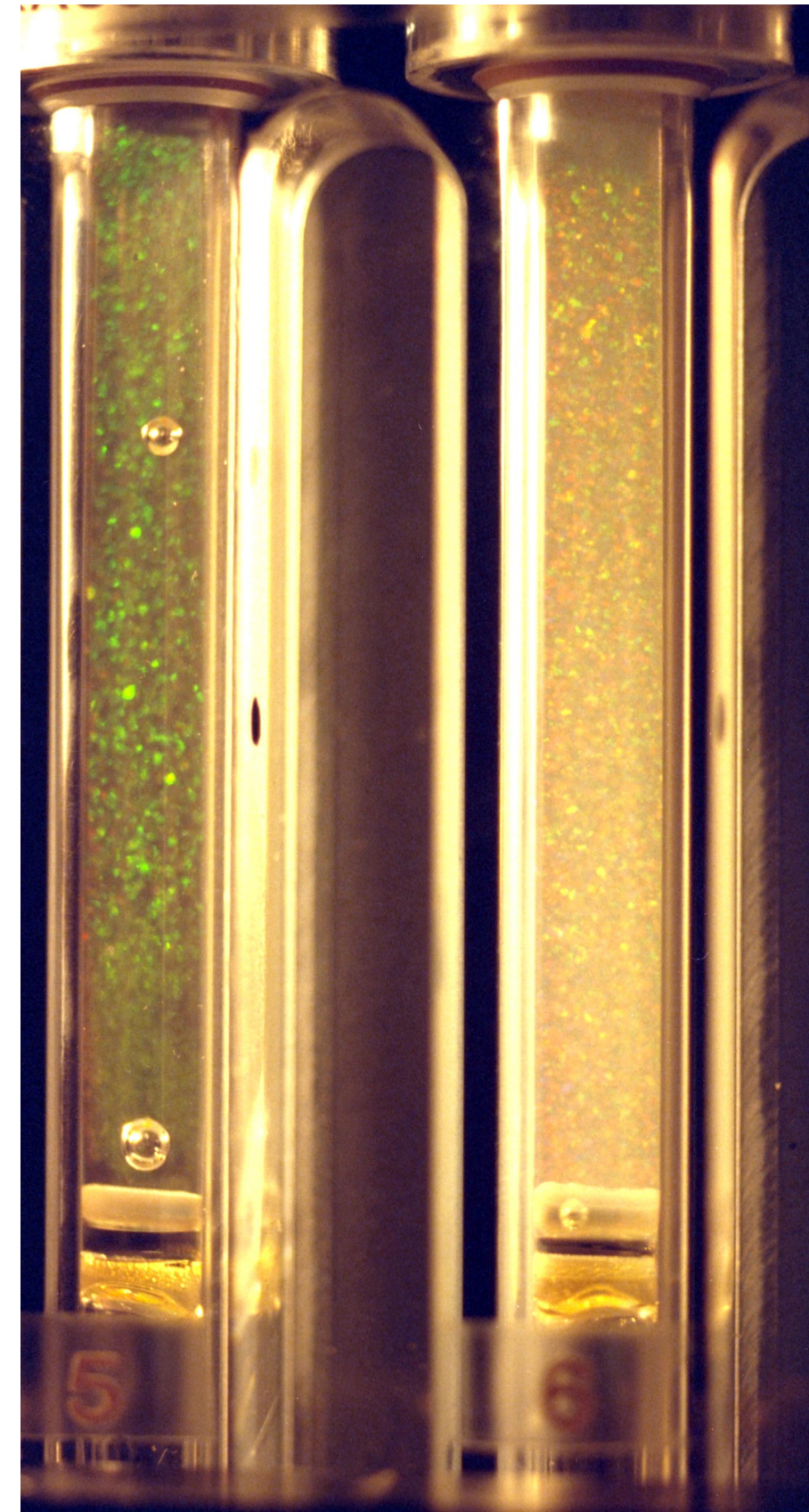

NASA5-311-035  
Figure MG-211 CGEL Tubes 5 & 6

# AMBIENT DIFFUSION- CONTROLLED CRYSTALLIZATION APPARATUS FOR MICROGRAVITY (DCAM)

## HARDWARE DESCRIPTION

### DCAM TRAY ASSEMBLY

Each Ambient Diffusion-Controlled Crystallization Apparatus for Microgravity (DCAM) tray assembly consists of 27 DCAMs containing biological materials arranged in nine rows of three units each, hard mounted to an aluminum tray. The DCAM tray assembly provides two levels of containment which are summarized below.

### Level 1

Each DCAM is comprised of three major components; 1) housing, 2) protein sample plug, and 3) plug. Both plugs are threaded and have a groove on their inside face for an o-ring. Prior to assembly a Viton o-ring is placed in each groove on both plugs. The plugs are then screwed into each end of the housing, compressing the o-ring between the housing and the plug.

Also located in each plug is a threaded hole which is used for sample loading and removing unwanted air from the DCAMs. This hole is sealed with a nylon screw and Viton o-ring or washer.

### Level 2

After the DCAMs have been loaded, they are assembled in groups of three to form the rows of the DCAM tray assembly. The major components of each row consist of three DCAMs, two side supports, two view ports, and four rods.

A Viton gasket is placed between the center DCAM and each of the outer DCAMs. The center DCAM contains a recess in which the ends of the outer DCAMs and gaskets can be partially inserted. Another gasket is placed between the other ends of the outer DCAMs and the view port/side support assemblies. The side supports also contain a recess in which the ends of the outer DCAMs can be partially inserted along with the view ports and gaskets.

Rods that have a hexagonal head on one end and are threaded on the other are inserted through holes located at each corner of the DCAMs. Each rod is secured with a flat washer, lock washer, and nut. This provides the force required to compress the gaskets and form the second level of containment.



Figure MG-213 DCAM Tray in Mir

NM21-390-32

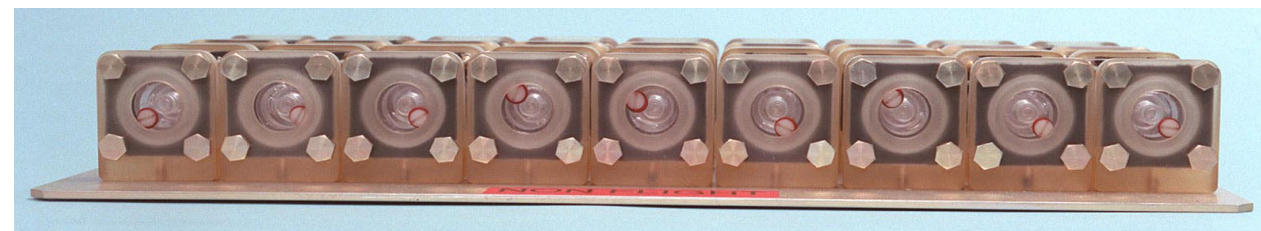

Figure MG-214 Training DCAM Side View

S97-01005



Figure MG-212 DCAM and Nikon F3 in Mir

NM21-390-34

D.I.D.

DCAM

**Principal Investigator:**  
Dan Carter, Ph.D.  
New Century  
Pharmaceuticals  
President  
(205)461-0024

Keith Higginbotham  
(205)544-5900

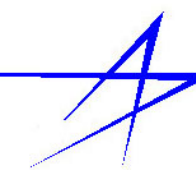

The DCAM does not employ mechanical activation/deactivation. Each DCAM will self-activate as the precipitant solution slowly diffuses through the delay plug from the large precipitant chamber to the smaller precipitant chamber. The protein "button" chamber projects into the smaller precipitant chamber.

The protein solution in the "button" chamber is separated from the precipitant by a dialysis membrane placed over the "button" and held in place by an o-ring. Through diffusion, water is removed from the "button" until equilibrium is reached and protein crystals are formed. Selected DCAMs on each of the tray assemblies can be observed and photographed from the side of the tray.

For transfer and stowage, Velcro straps will be used and each DCAM tray assembly will be protected by a cover bag. Velcro located on the tops and bottoms of each bag allows DCAM/bag assemblies to be attached to one another. As a result, DCAM/bag assemblies can be transferred and stowed in different combinations depending on the number of assemblies being flown.

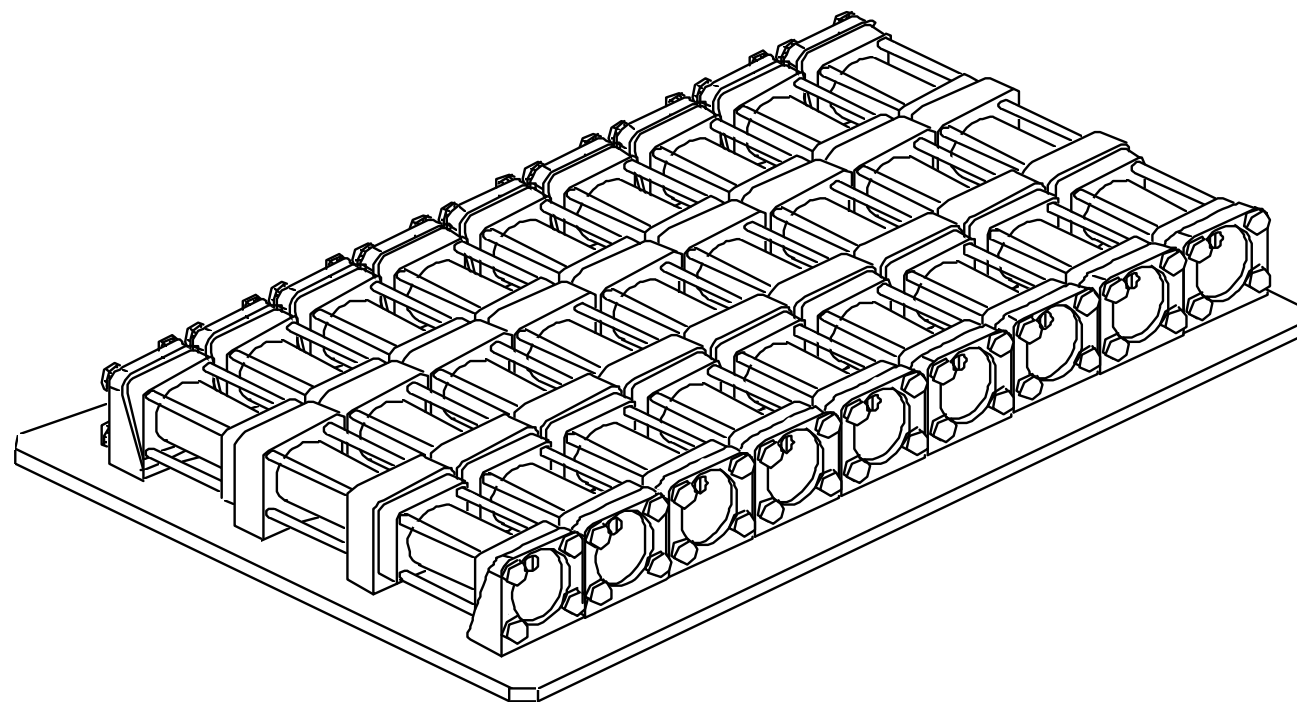
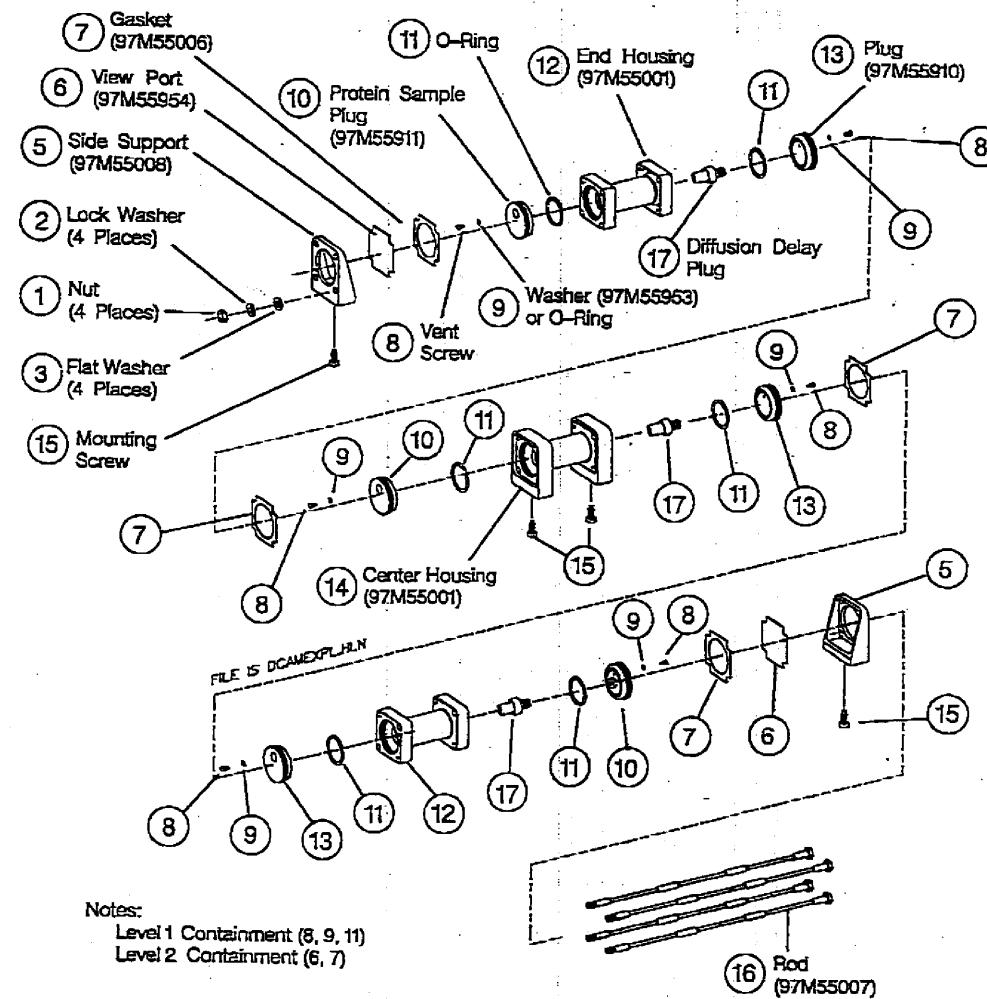

Figure MG-215 DCAM Tray Assembly (Orthogonal View)

### HARDWARE INTERFACE WITH SYSTEMS

The DCAM hardware is launched aboard the Orbiter in two stowage locations from Kennedy Space Center (KSC). After rendezvous with Mir, the units will be transferred from the Orbiter to the Mir station for integration. Once on Mir the DCAM hardware will be stowed using the provided Velcro straps and/or straps already on the Mir station. Each DCAM assembly, including cover bag, weighs approximately 24.2 lbs.

The desired ambient temperature on the Orbiter and Mir around the DCAM hardware is  $22^{\circ}\text{C} \pm 4^{\circ}\text{C}$ . \*



DCAM Growth Chamber (Exploded View)

Figure MG-216 DCAM Growth Chamber (Exploded View)

### AMBIENT DCAM TRAY ASSEMBLY

P/N: 97M55013-1  
 Qty.: 6  
 Mass: 30 kg  
 Power: N/A  
 x,y,z: 45.72 x 30.99 x 8.38 cm  
 Loc: Kristall, Panel 308  
 DID#: SLM46113643

On-Orbit Temp. (internally mounted h/w):  
 18-26 °C

Gas Environment Composition:  
 Nitrogen - up to 78%  
 Oxygen - up to 40%  
 Carbon dioxide - up to 3%  
 Helium - up to 0.01%  
 Hydrogen - up to 2%

Pressure (On-Orbit inside the station):  
 450 - 970 mmHg

Relative Humidity (On-Orbit):  
 10 - 80% within temp range of 5-40 °C; (assuming no water condensation on h/w surface)

Orbital Radiation Environment (Internal h/w):

Considered protection layer thickness: 1g/cm<sup>2</sup>  
 Doses at flight duration of 3 years galactic space radiation:  
 radiation belts - 150 rad  
 sun flares - 40 rad

Maximum dose rate galactic space radiation:  
 radiation belts - up to 5 x 10<sup>-3</sup> rad/h  
 sun flares up to 2.5 rad/h

Expected Operational Life:  
 1 year

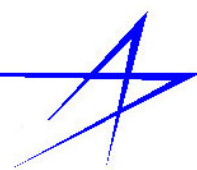

# INTERFEROMETRIC STUDY OF PROTEIN CRYSTAL GROWTH - MGBX (IPCG)

## EXPERIMENT DESCRIPTION

Provide a technology demonstration and development effort of an interferometry system to study protein crystal growth (PCG). Study solute concentration gradients about growing protein crystal to obtain evidence regarding the role of growth unit aggregation in IPCG.

## HARDWARE DESCRIPTION

Table MG.9 lists the IPCG hardware required for performance of the experiments.

TABLE MG.9  
IPCG HARDWARE LISTING

Hardware Description	Qty
IPCG Base Plate	1
IPCG Optics Bench Assy	1
IPCG Fluid System	6
IPCG Translation Stage	1
IPCG Computer	1
Cables	7
Accessory Bag	1
Handwheel	1
Magnifier	1
Locking Handle	1
Height Gauge	1
Attach Plate Screws	4

D.I.D.

Interferometric Protein  
Crystal Growth

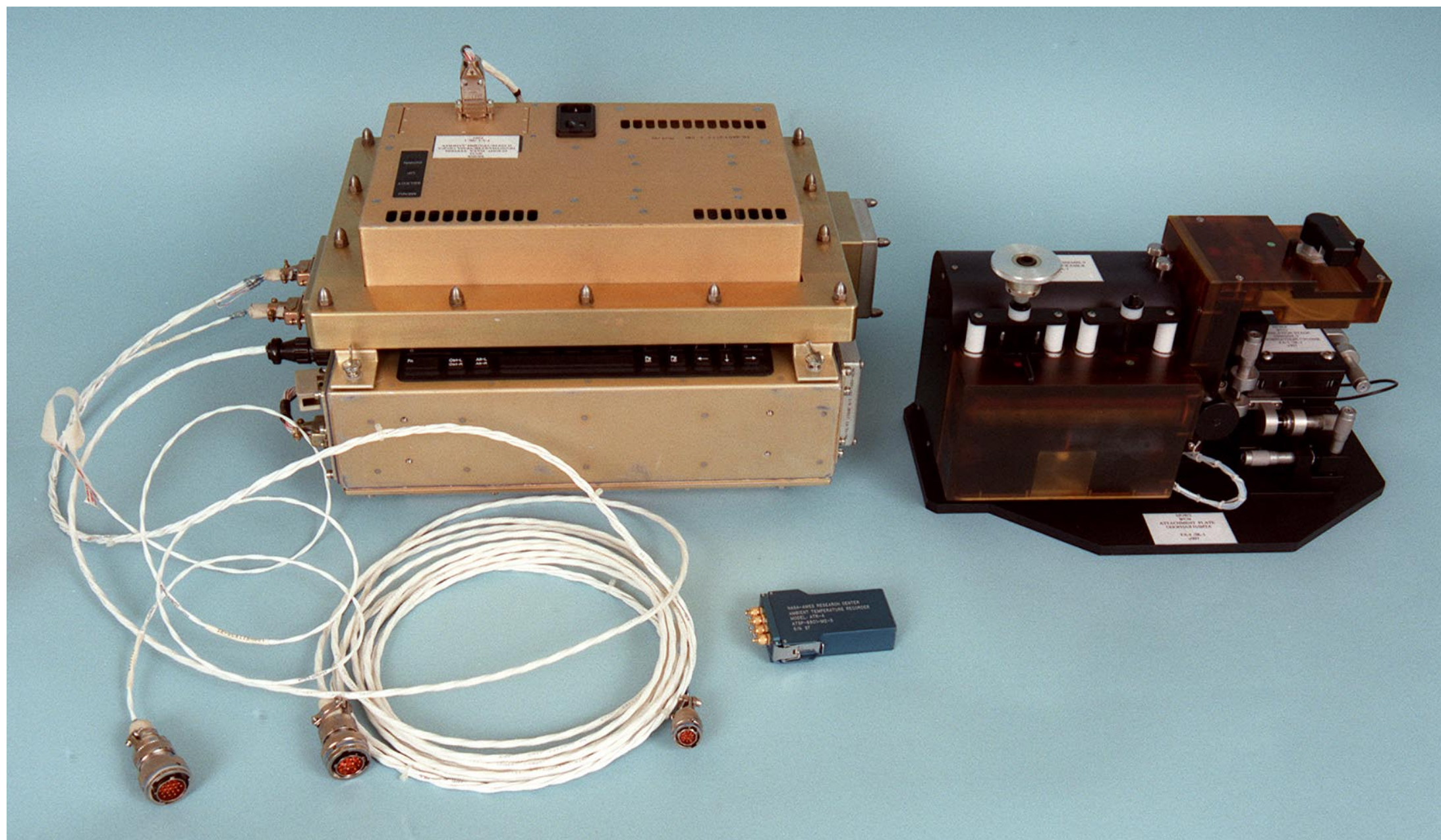

## PRINCIPAL INVESTIGATOR

Dr. Alex McPherson,  
University of California-Riverside

## IPCG - EXPERIMENT ASSEMBLY

Power Consumption:  
250 mW  
Start-Up Current:  
250 +/- 100 sec \mamps,  
250 +/- 100 msec  
Onboard Electrical Supply:  
MGBX power  
Insulation Resistance:  
Same

## IPCG - FLIGHT DATA SYSTEM

Power Consumption:  
100 - 120 W  
Start-Up Current:  
70 amps, 15 msec  
Onboard Electrical Supply:  
MGBX power  
Insulation Resistance:  
Same

Figure MG-217 IPCG Experiment and Accessories

S97-05277



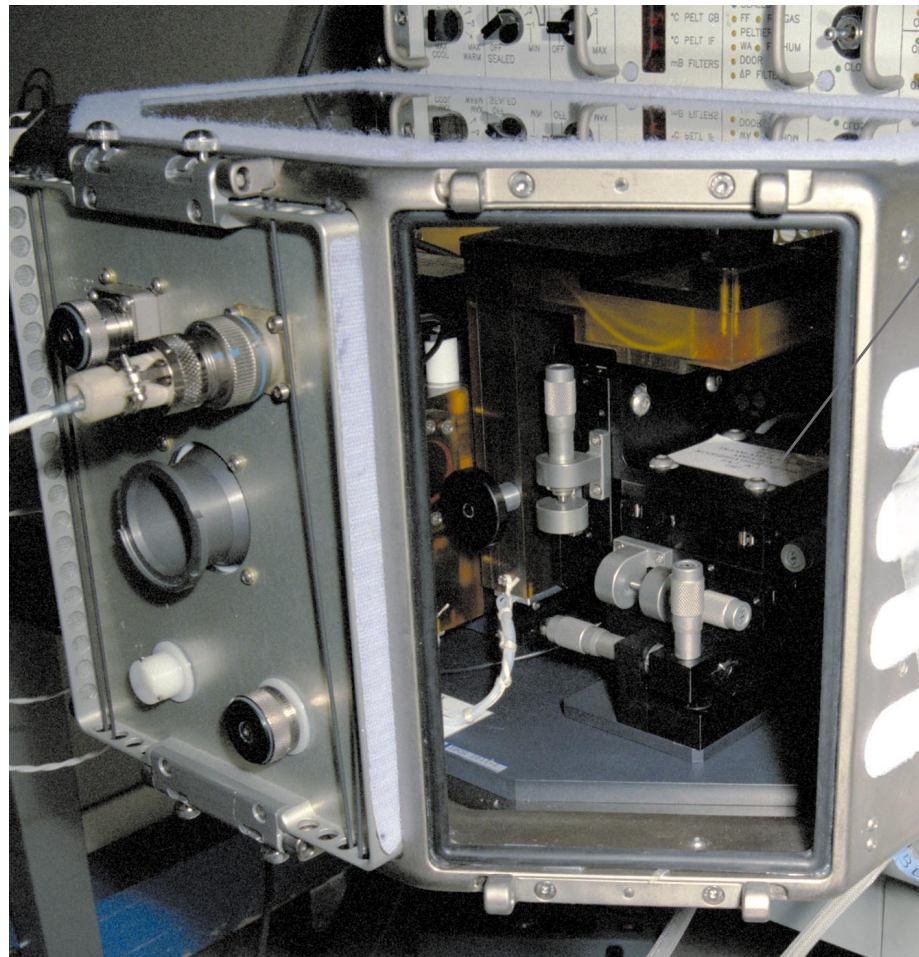

Figure MG-218 IPCG in MGBX Through Right Opening S97-06677

Translation Table

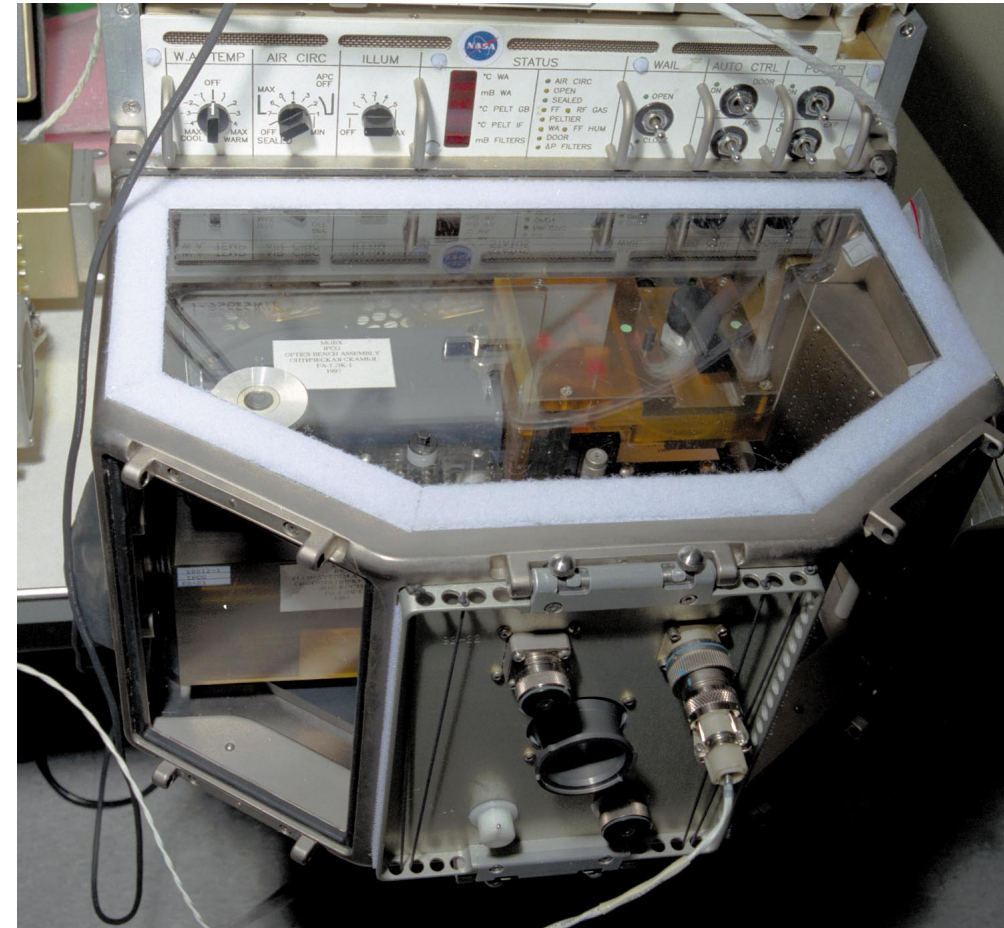

Figure MG-219 IPCG in MGBX, Top View S97-06680



Figure MG-220 IPCG in MGBX Through Left Opening S97-06678



A

**BASEPLATE**

The baseplate is the mechanical interface between the IPCG experiment hardware and the MGBX. It is fixed to the MGBX work area by means of several screws and provides attachment points for the Optical Bench Assembly.

For installation onto Baseplate (A) of Translation Stage Assembly (B) and Optical Bench Assembly (C).

Figure MG-221 Baseplate

S97-05285

B

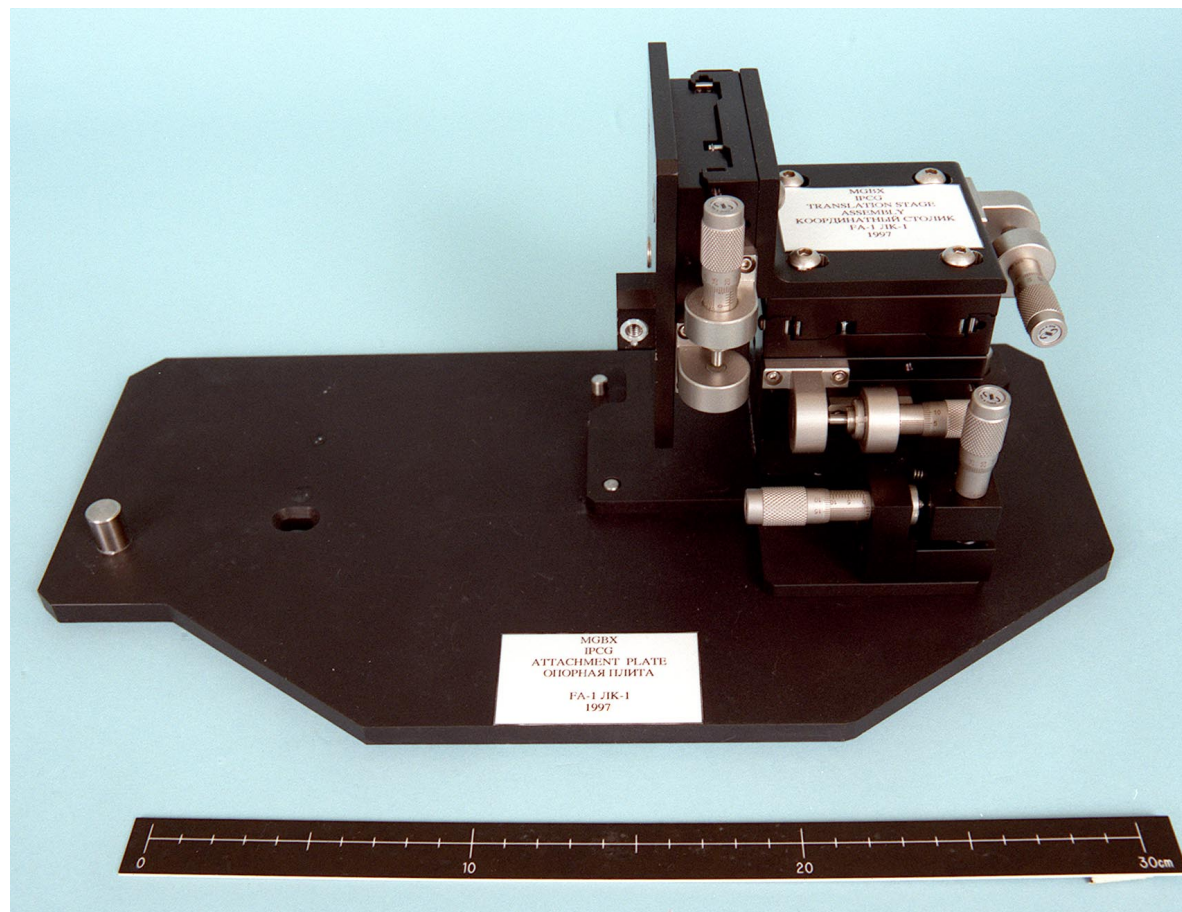

Figure MG-222 Translation Stage Assembly on Baseplate

S97-05284

C

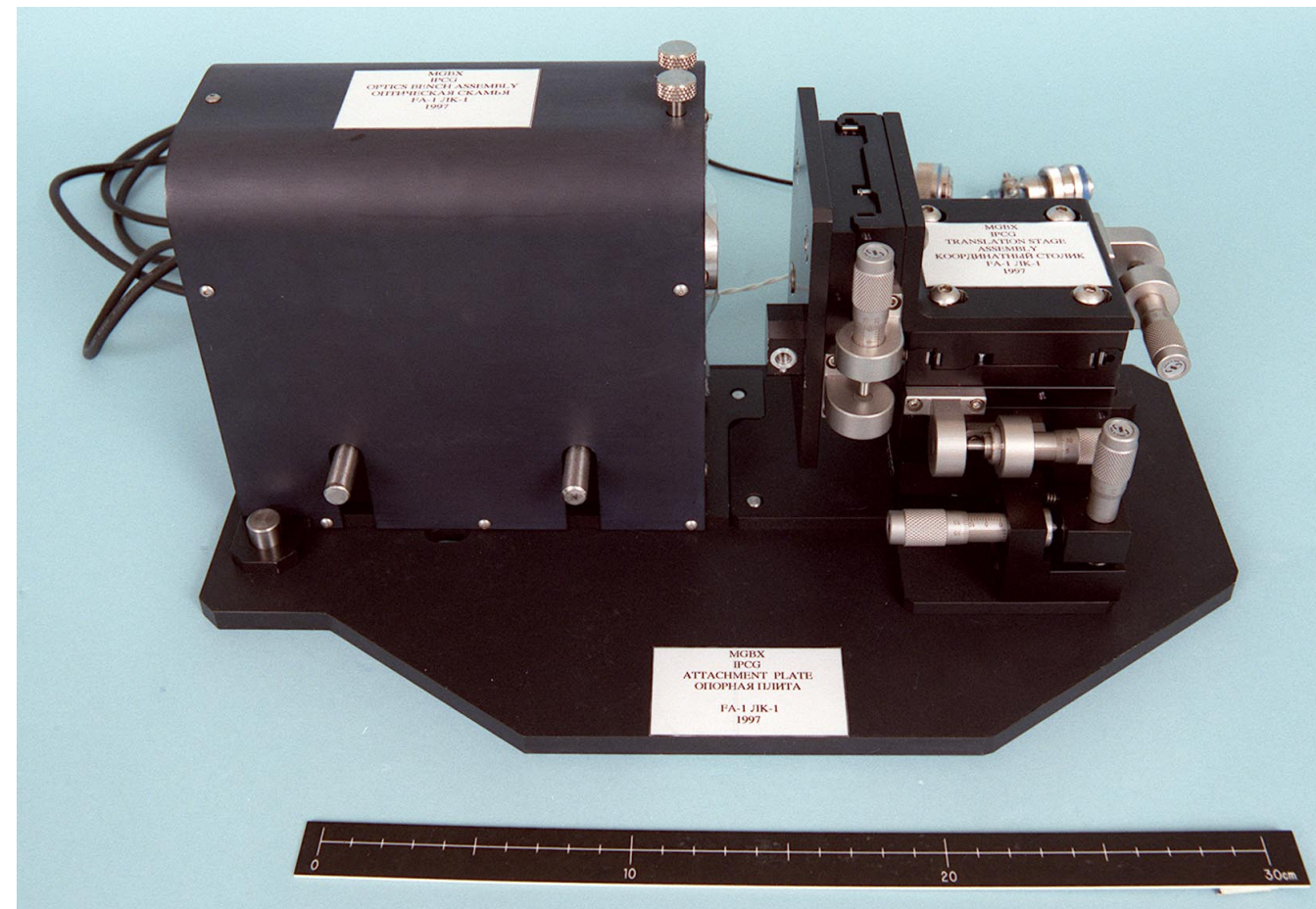

Figure MG-223 Optical Bench Assembly and Translation Stage Assembly on Baseplate

S97-05283

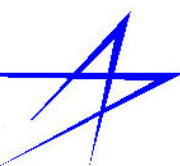



Figure MG-224 End View S97-05437

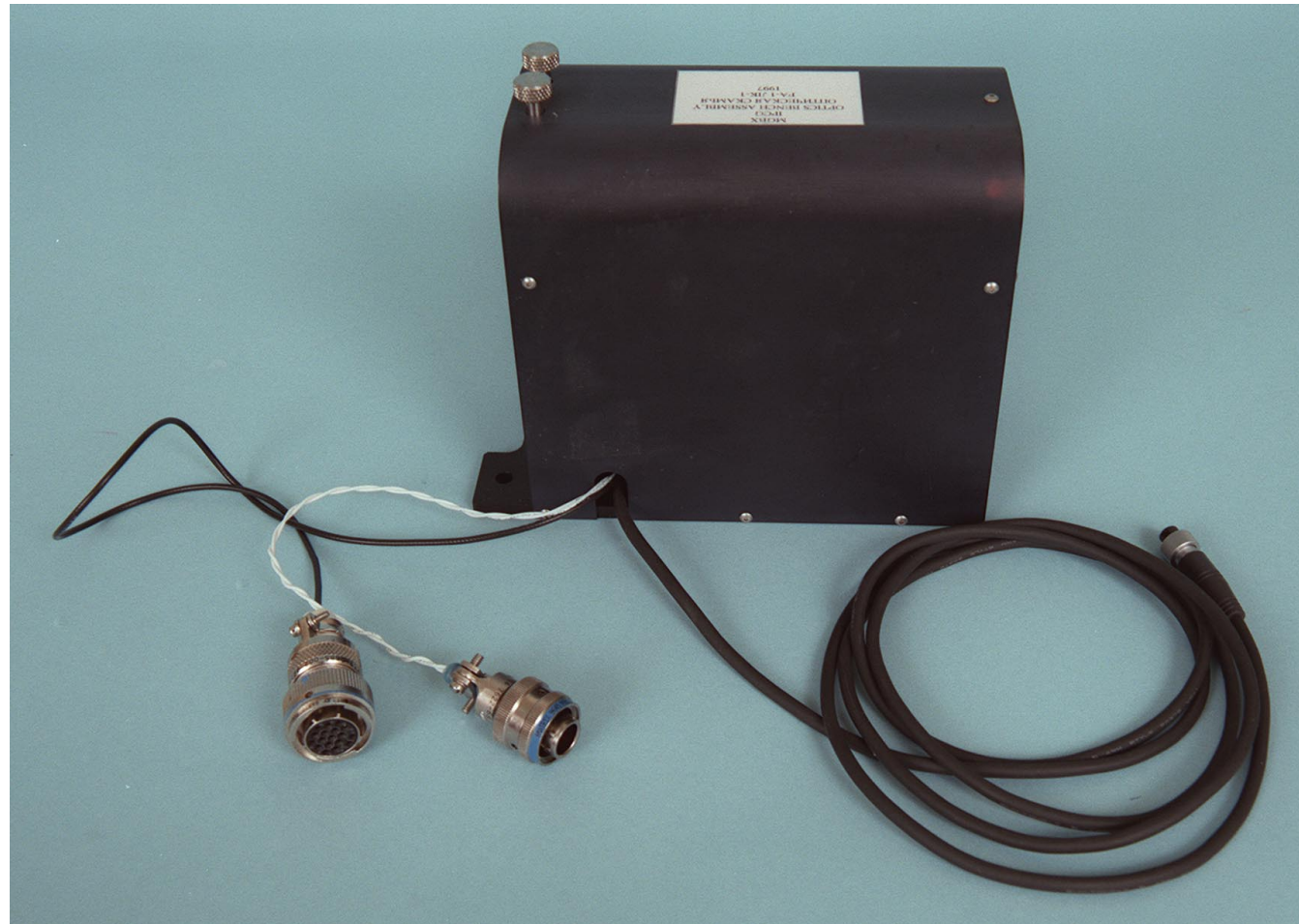

Figure MG-225 Optical Bench Assembly S97-05436

### OPTICAL BENCH ASSY

The optical system of the IPCG is a Michelson-Morley phase shift interferometer, which uses a 5 mW laser diode. The polarization vector of the laser is set at a 45° angle. A polarizing cube beamsplitter divides the light into two equal intensity beams. The polarizing cube beamsplitter transmits the horizontal polarization angle and reflects the vertical polarization angle. Attached on each of the output faces of the cube beamsplitter is a quarter waveplate. The two beams pass through the quarter waveplates. One of the quarter waveplates converts the horizontal polarization into right-handed circular polarized light. The other quarter waveplate converts the vertical polarization into left-handed circular polarized light.



Figure MG-226 End View S97-05435

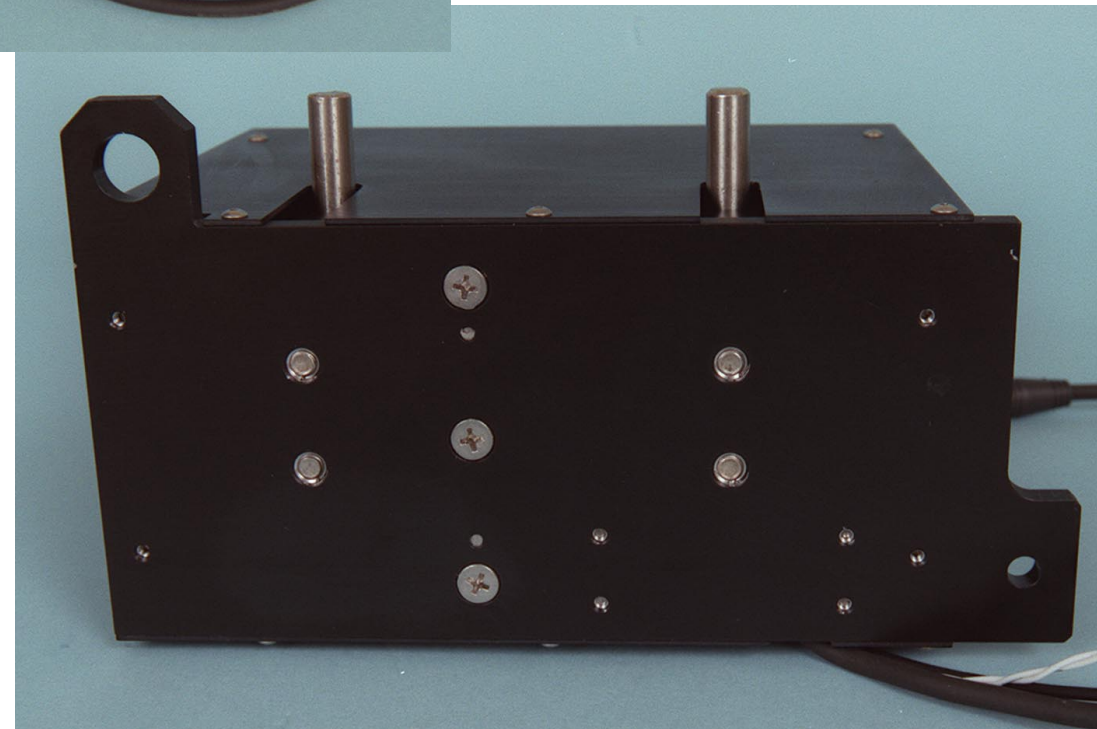

Figure MG-227 Interface to Baseplate, Bottom View S97-05434

The right-handed circular polarized light travels to the reference mirror. Upon reflection it becomes left-handed circular polarized light which then passes back through the quarter waveplate. After passing through the quarter waveplate, the left-handed circular polarized light becomes vertical polarized light which reflects in the polarizing cube beamsplitter towards the microscope objective.

The left-handed circular polarized light travels to the protein crystals where it reflects. The left-handed circular polarized light becomes right-handed circular polarized light after reflection from the protein crystals. The right-handed circular polarized light passes back through a quarter waveplate and converts to a horizontal polarized light. The polarizing cube beamsplitter transmits the horizontal polarized light towards the microscope objective.

The two beams, one with a vertical polarization angle and the other with a horizontal polarization angle, recombine in the cube beamsplitter. The two beams pass through a 50x long working distance microscope objective. The objective magnifies and images the protein crystals onto the video camera.

The next element that the beams pass through is the liquid crystal phase modulator. The phase modulator shifts the phase of the horizontal polarized beam only, leaving the vertical polarized beam unaffected. A dove prism folds the light path to increase the optical path length while maintaining a small footprint for the device.

The last component that the beams pass through before striking the video camera is a linear polarizer. The linear polarizer is at a 45° angle so that components from the two orthogonal beams can create interference fringes. Control of the phase modulator is from the output of a computer controlled digital- to-analog converter. The camera in the system is the same as the standard glovebox camera. The Data and Video Interface Drawer (DAVID) outputs the video signal to the IPCG computer frame grabber. The frame grabber collects the phase shifted images and places them in storage for later analysis. The capacity to analyze the data with the onboard computer will be present if a qualified scientist is conducting the experiments.

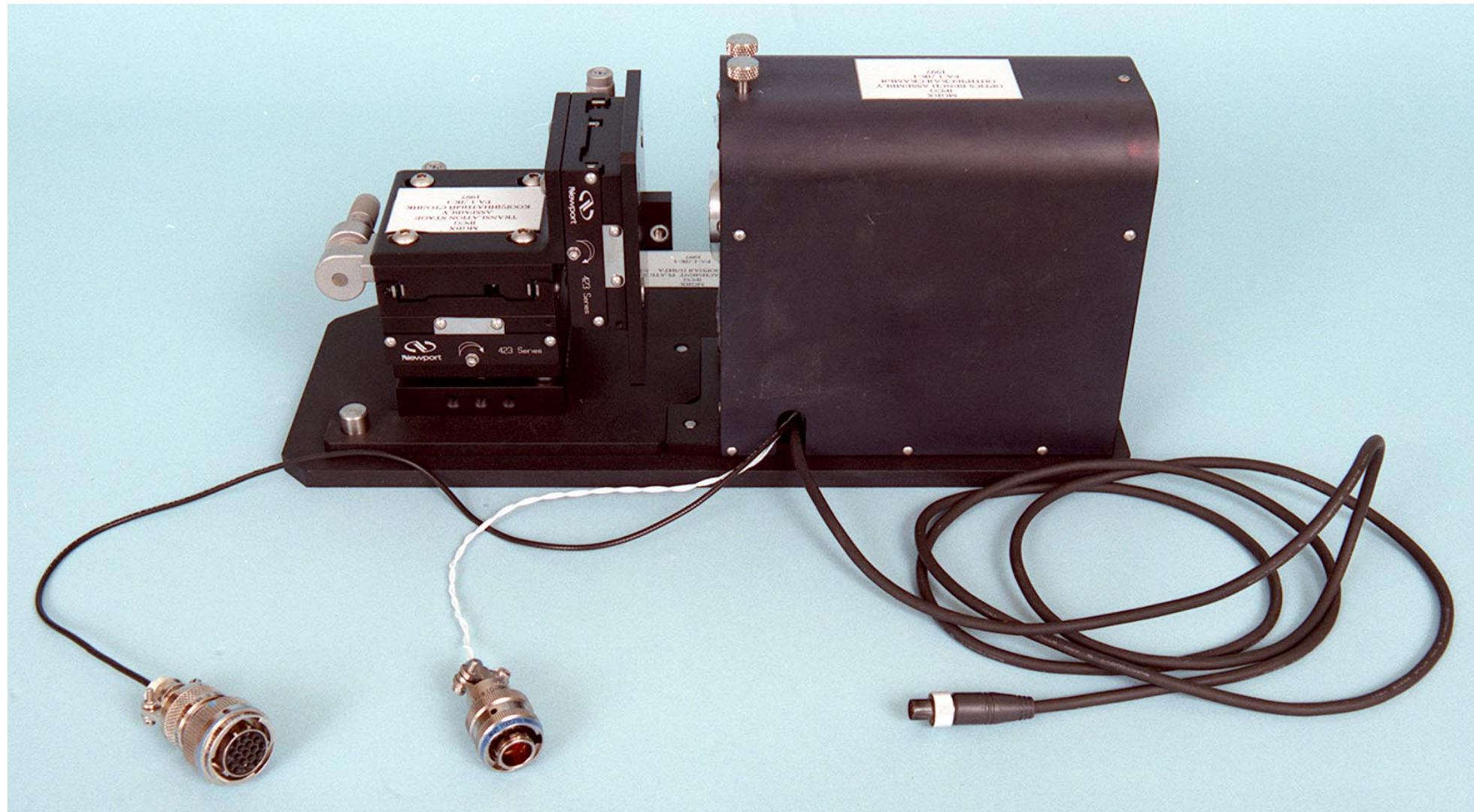

Figure MG-228 Optics Bench with Translation Stage Assembly

S97-05282

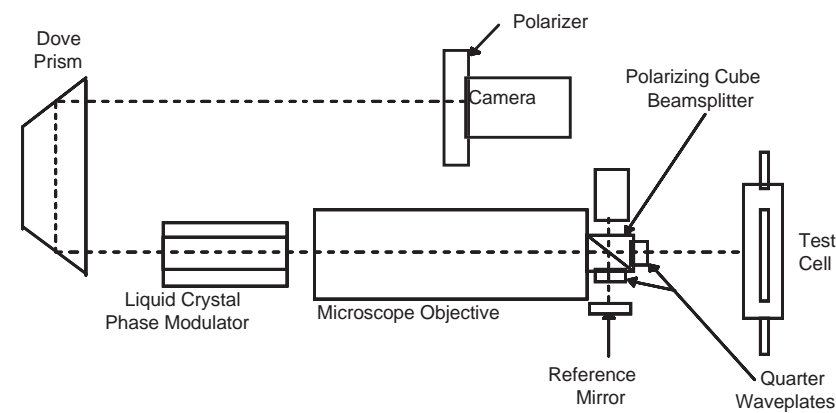

Figure MG-229 IPCG Optics Layout



## FLUID SYSTEM

The crystal growth experiments will be carried out at ambient temperatures on the orbiting vehicle. It is preferred that the experiments be carried out at temperatures in the 18 to 22°C range, and that the current ambient temperatures of the apparatus during the experiment be recorded as part of the experimental data.

The solutions for the crystal growth experiments will be contained in a syringe block of two syringe pairs and a single waste solution container. A manually operated crank will enable the slow expression of solutions from the syringes, one pair at a time. The solutions so expressed will pass down a Teflon tube to a high-efficiency low-velocity mixing T, and thence into the growth cell. After passing through the growth cell the solutions will pass, via another Teflon tube, to the waste solution container. All syringe solutions will be loaded prior to launch, and the growth cell and fluid lines from the ends of the syringes to the waste solution syringe will be prefilled with degassed aqueous solution to minimize bubble formation during the experiment.

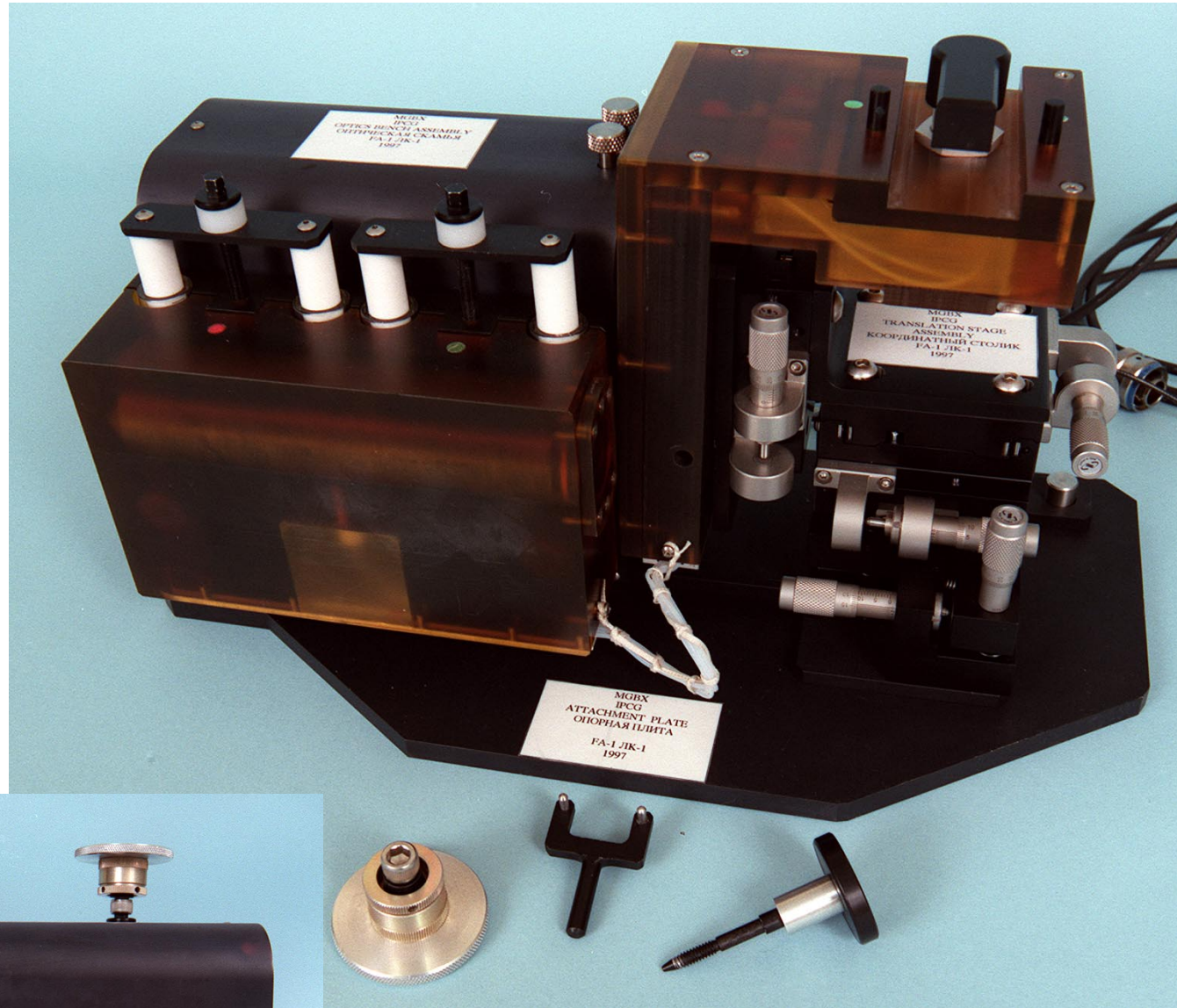

Figure MG-231 Fluid System Attached to Optical Bench Assembly and Translation Stage Assembly, with Accessories

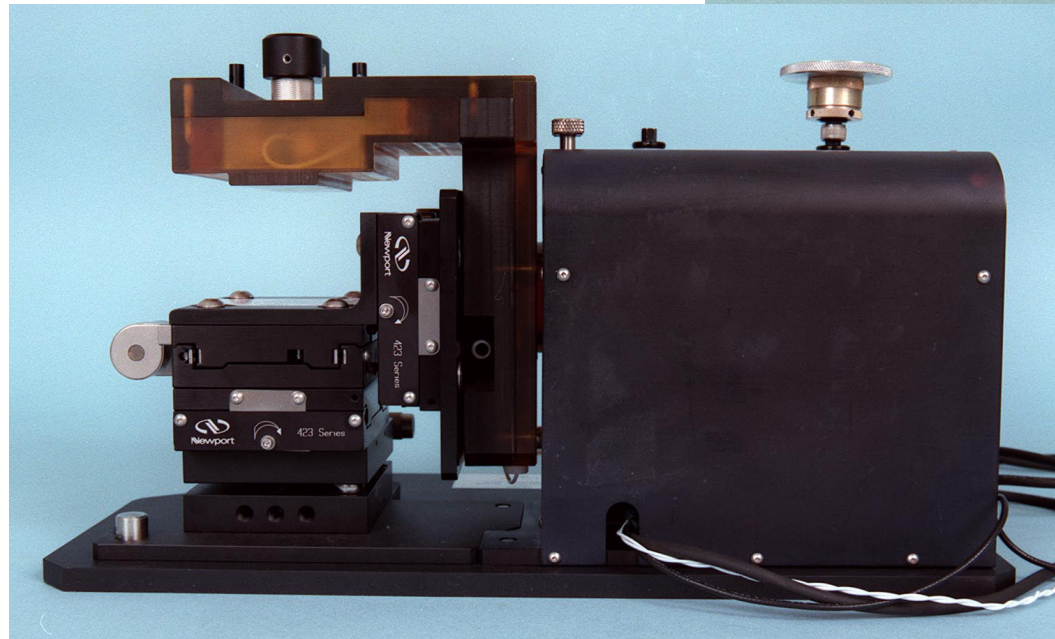

Figure MG-230 Rear View

S97-05262



Figure MG-232 Right End View

S97-05261

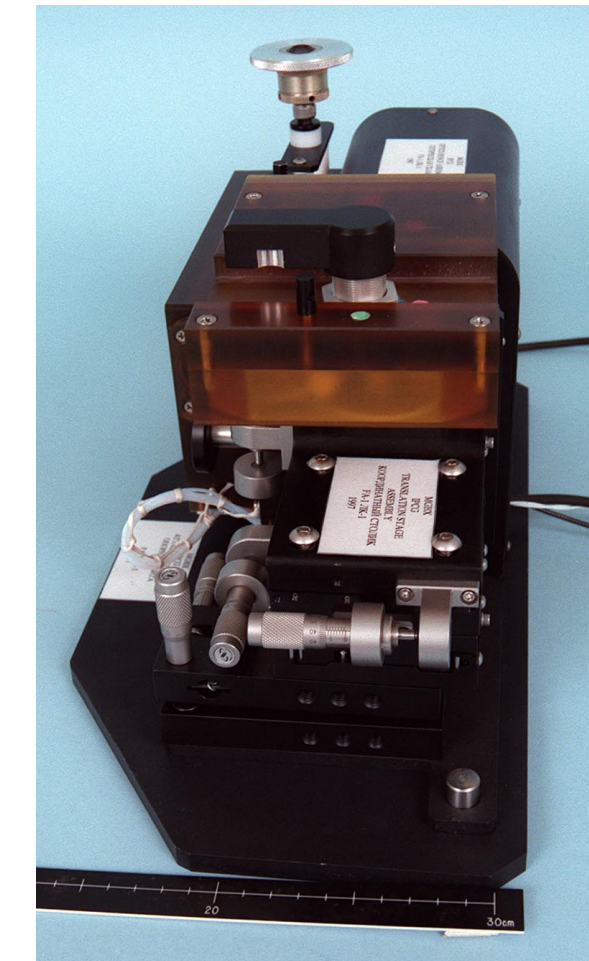
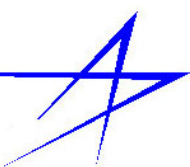

Figure MG-233 Top View

S97-05263



The growth cell will be made of high optical quality glass, striation and strain free, and have internal dimensions of the observation area of 1 x 5 x 10 mm (depth x height x width) or 1 x 10 x 20 mm. The ends of the observation areas will taper into 1/8" O.D. tubes, each about 3cm long, to be used for connecting the cells to the fluids system for solution control. The overall volume of the cells will thus be 75 or 250 mL (.075 or 0.250 mLs).

If one assumes a 4x volume is required to flush the cells to 95% of the new solution concentration, and approximately 5x volume to approach a 100%

replacement, then for the larger cell size a volume of approximately 800 mL (including the tubing volume before the cell) will be required to introduce a new protein solution. If the solutions are prepared immediately before introduction into the growth cells by mixing equal volumes of protein and precipitant solutions, then an estimated 400 mL of each solution will be required for each change of experimental conditions. A 2.0 mL (2000 mL) volume in each of four solution syringes thus will allow four separate experimental runs to be made.

If the first syringe pair contains protein solution for the nucleation of seed crystals within the cell, then the second half of the first syringe pair, and all of the second syringe pair solutions can be used for a total of three experimental runs. With six separate Fluid Assemblies, a total of 18 separate experimental runs can be conducted.

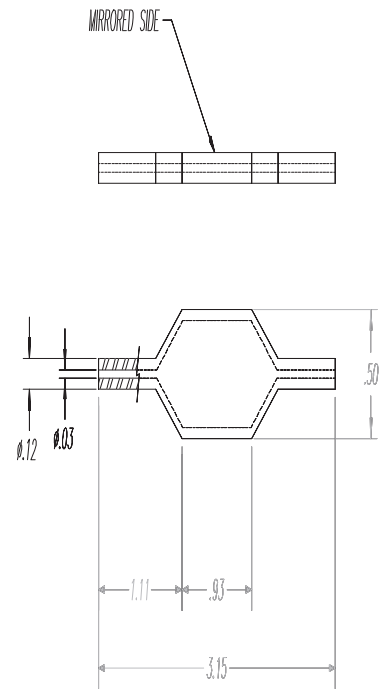

Figure MG-234 Growth Cell

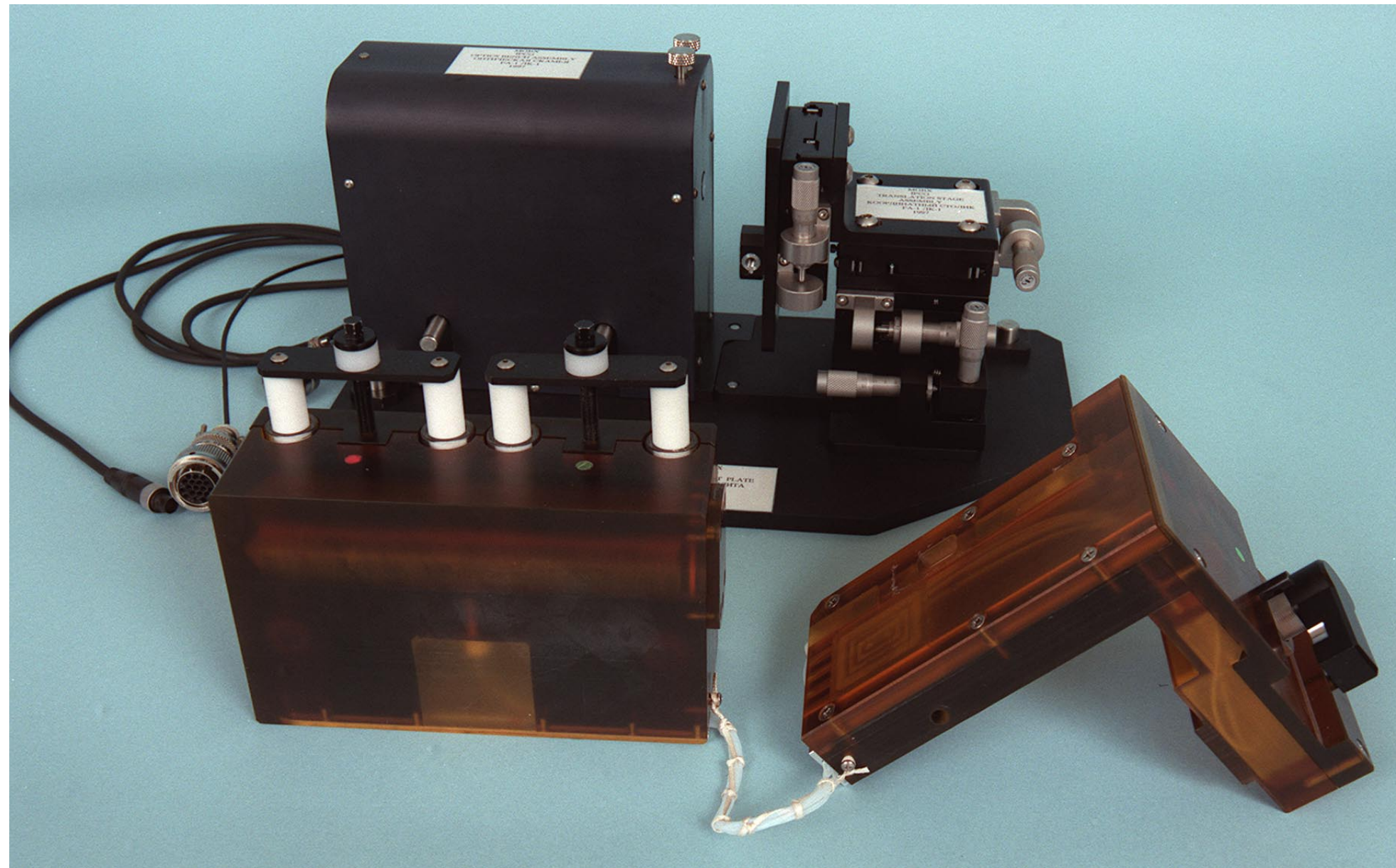

Figure MG-235 Fluid System Removed from Optical Bench Assembly and Baseplate

S97-05449



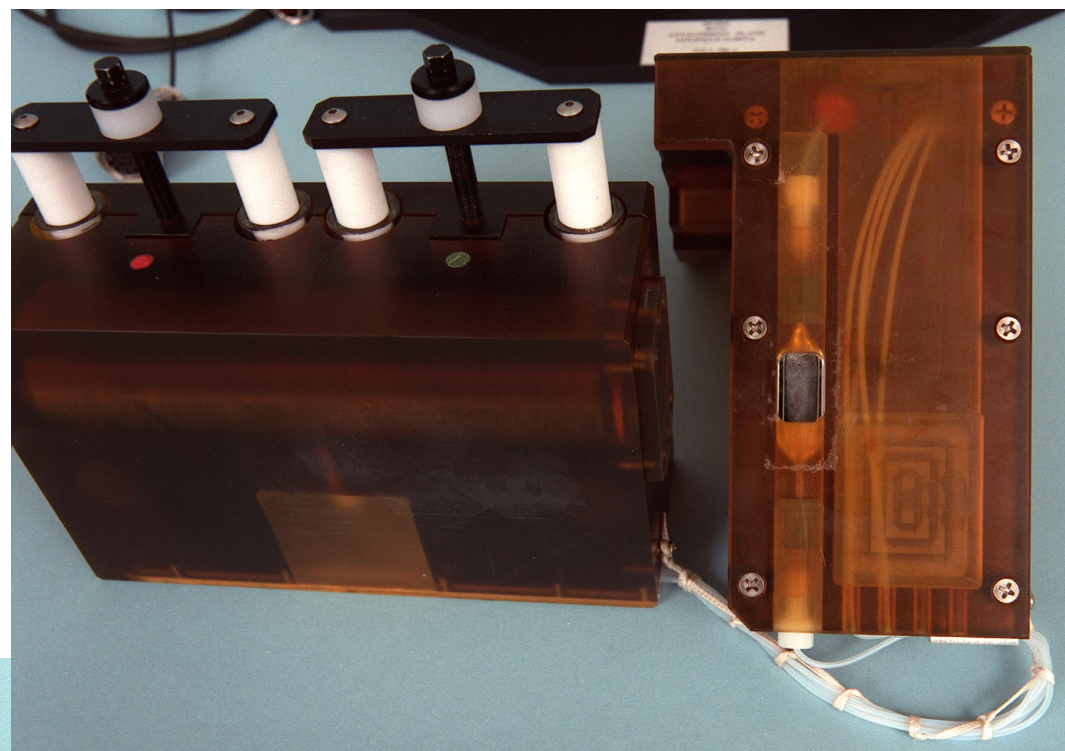

Figure MG-237 Back of Fluid System, Showing Solution Syringes S97-05448

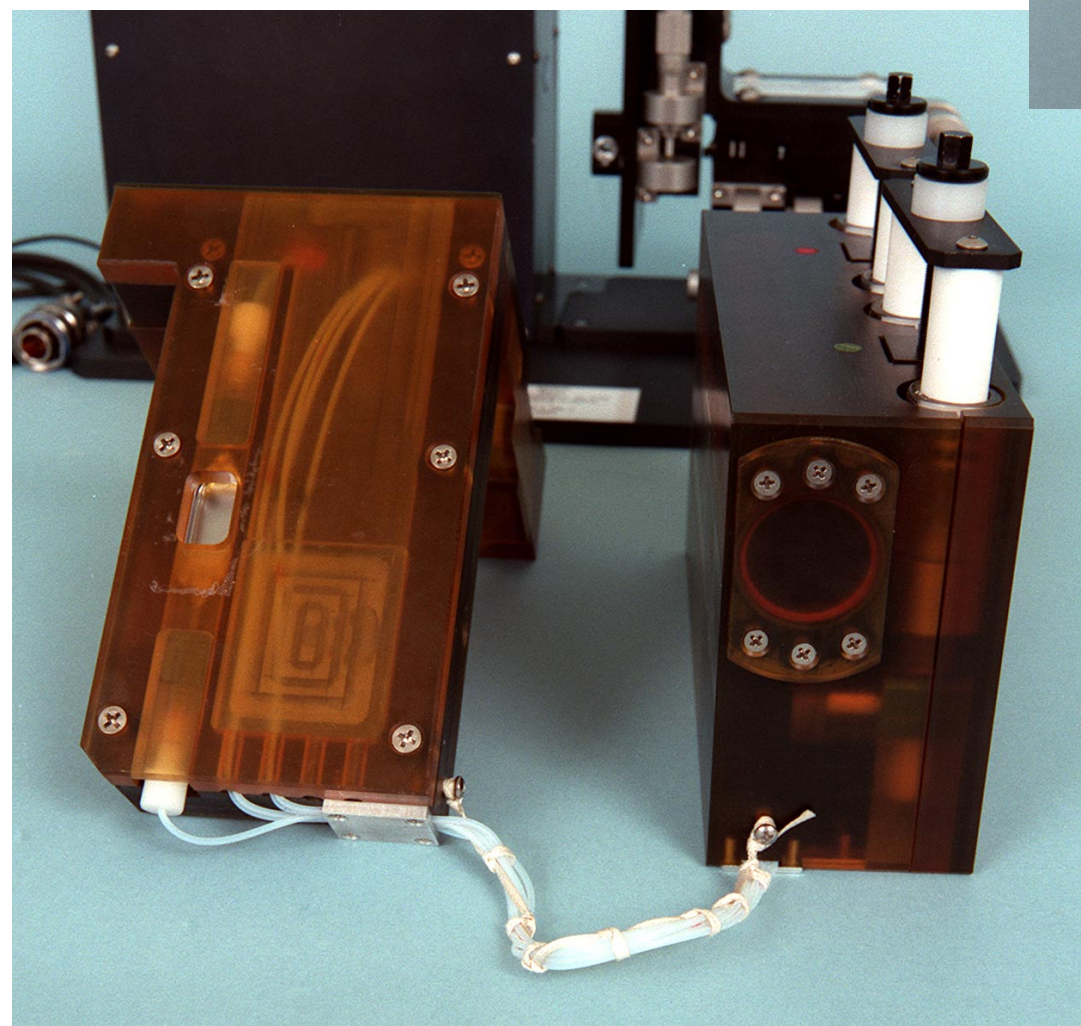

Figure MG-236 Side of Fluid System, Showing Solution Syringes S97-05446

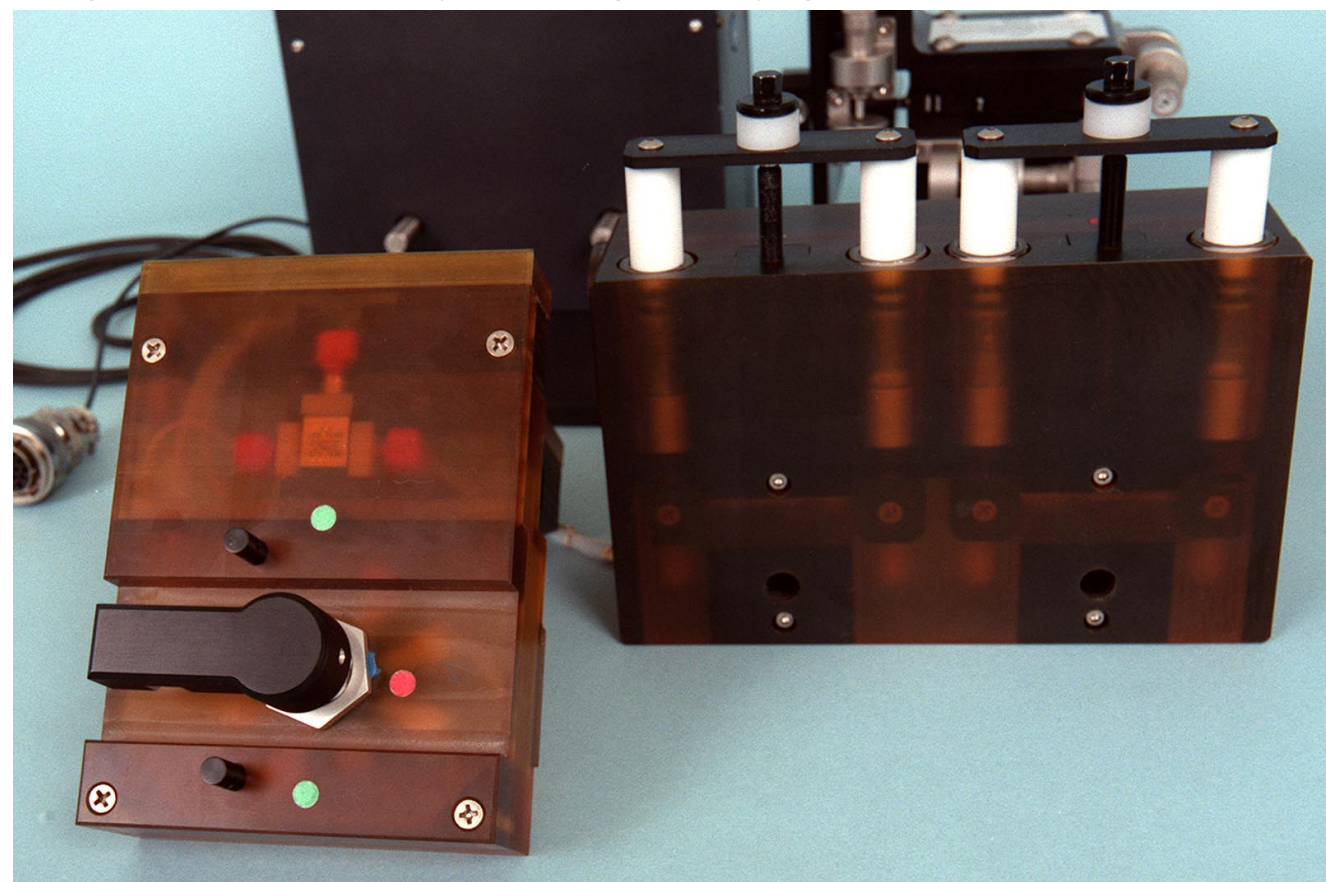

Figure MG-238 Top of Fluid System, Showing Solution Syringes S97-05447



## TRANSLATION STAGE ASSEMBLY

The Experiment Cell Assembly is designed to mount on the Translation Stage Assembly for crystal selection and viewing. The translation stage allows for movement in the x, y, and z directions as well as tilt and rotation. The growth cell is scanned (in the x and y directions) to identify a candidate protein crystal. The tilt and rotation controls are then adjusted for optimum cell viewing. Finally, the z translator is used to adjust the focus as needed.

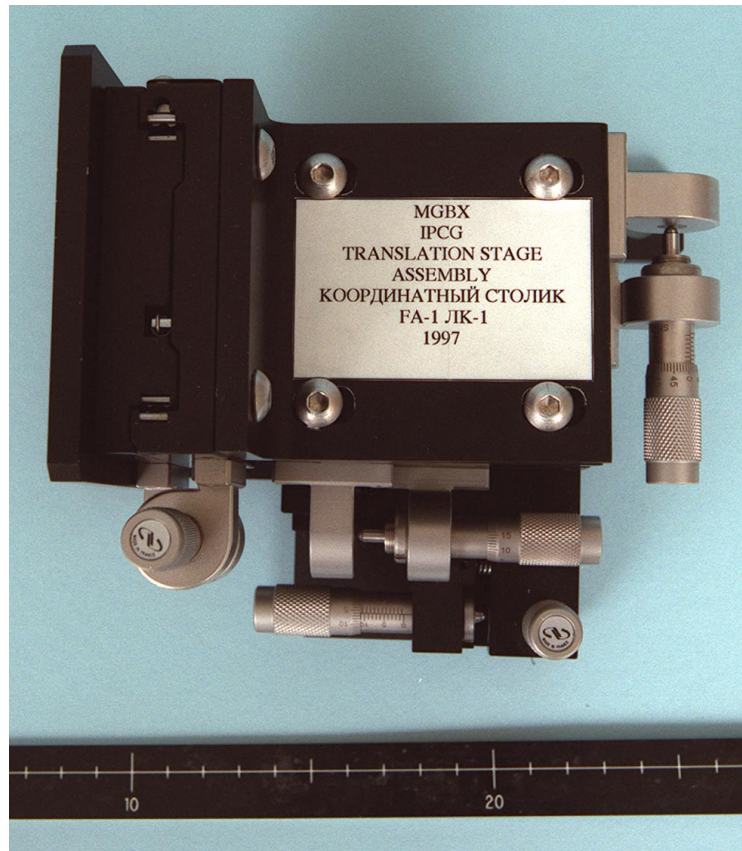

Figure MG-239 Translation Stage Assembly, Top View

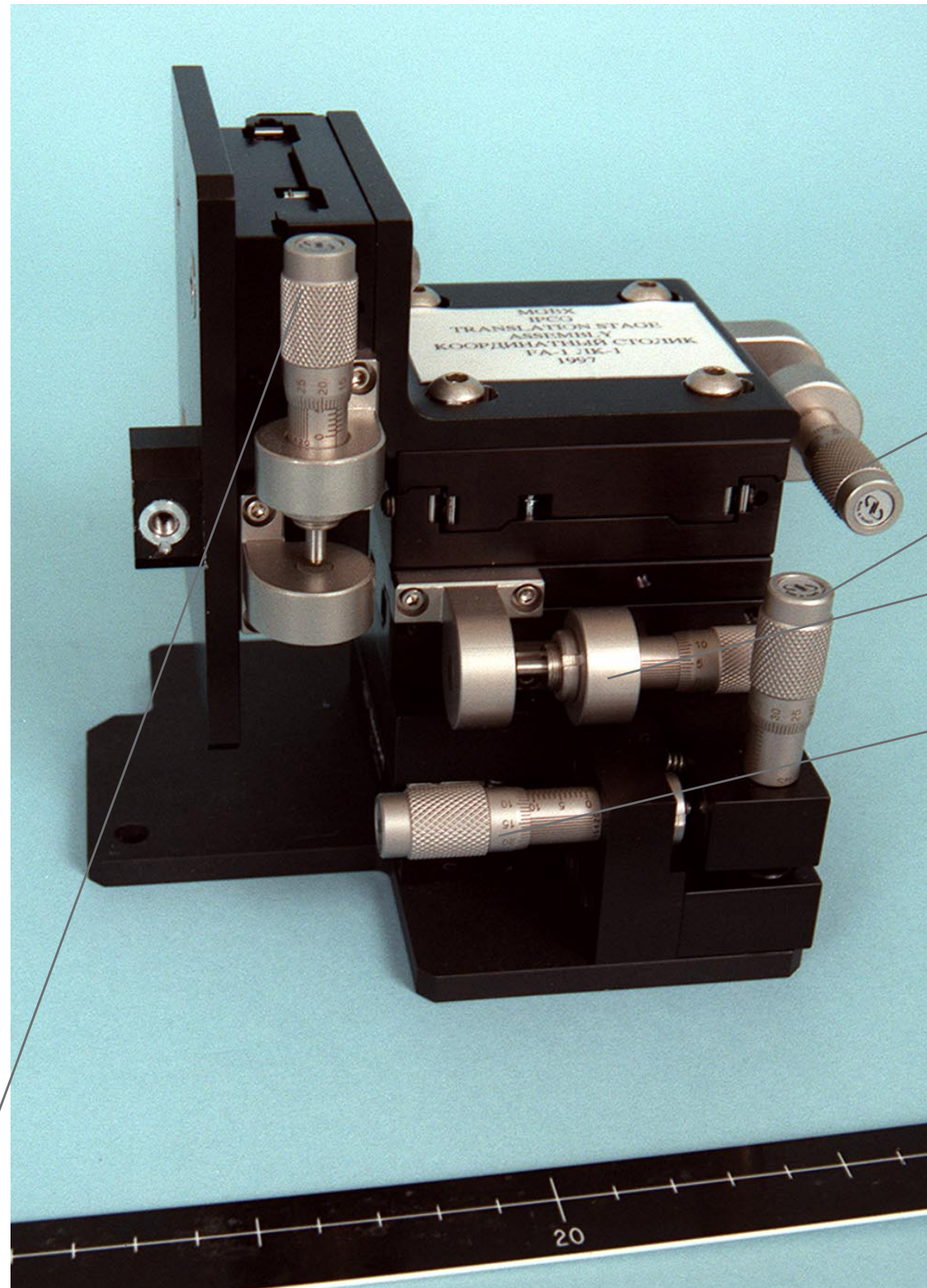

Figure MG-240 Translation Stage Assembly

- X Translator
- Z Translator
- Tilt Translator
- Rotation Translator

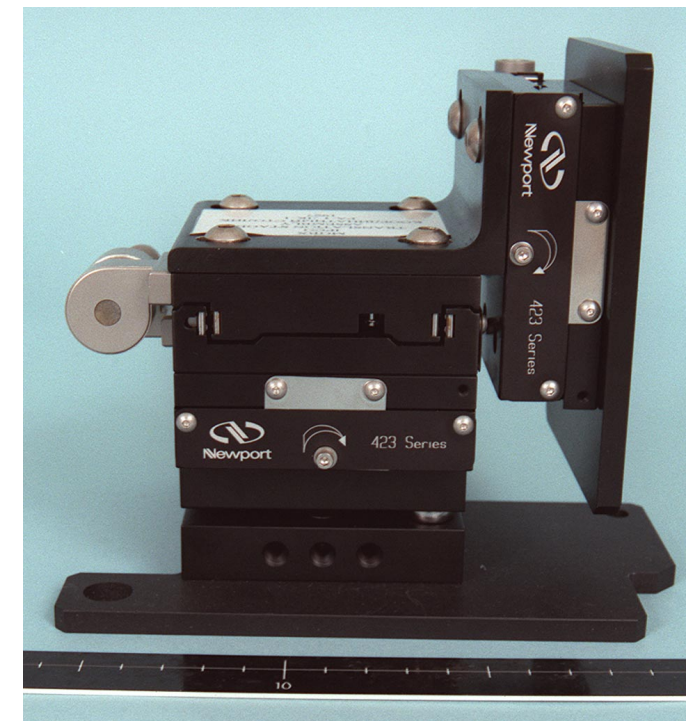

Figure MG-241 Translation Stage Assembly, Side View

Y Translator



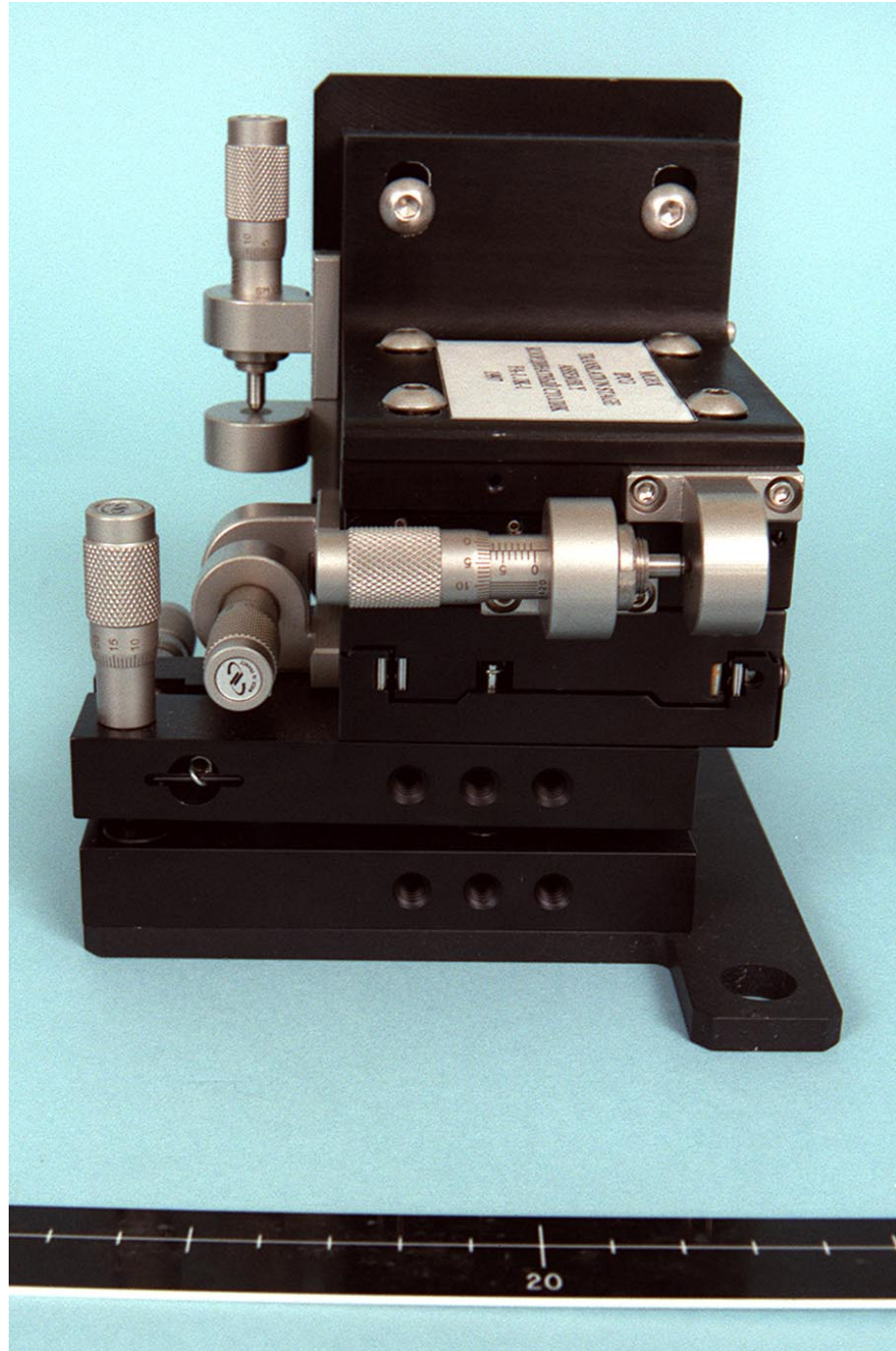

Figure MG-242 Translation Stage Assembly, Side View S97-05441

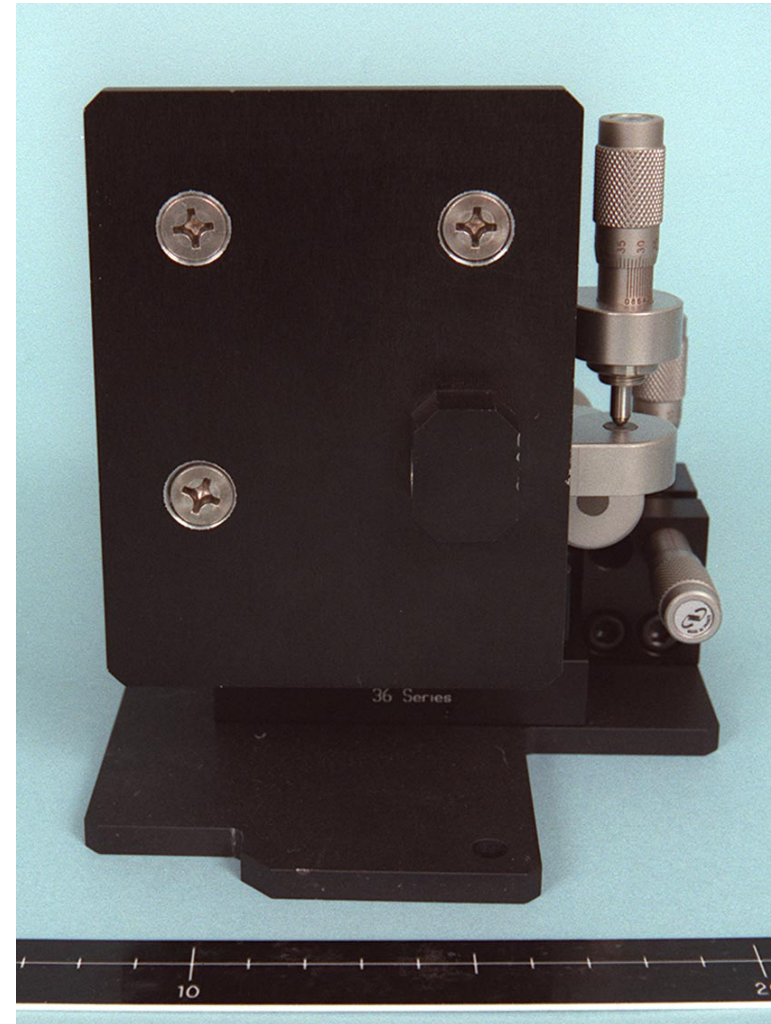

Figure MG-243 Translation Stage Assembly, Bottom View S97-05439

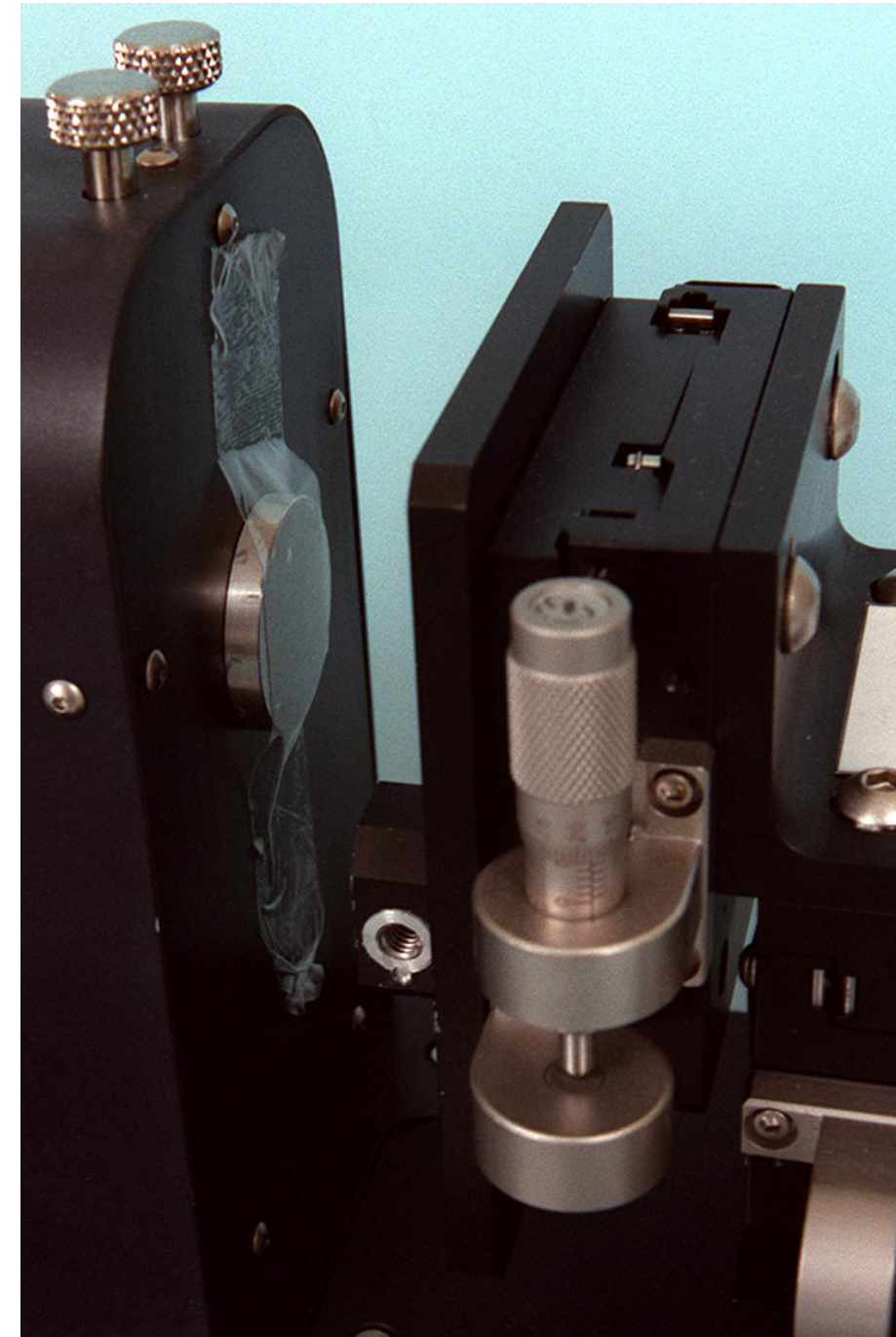
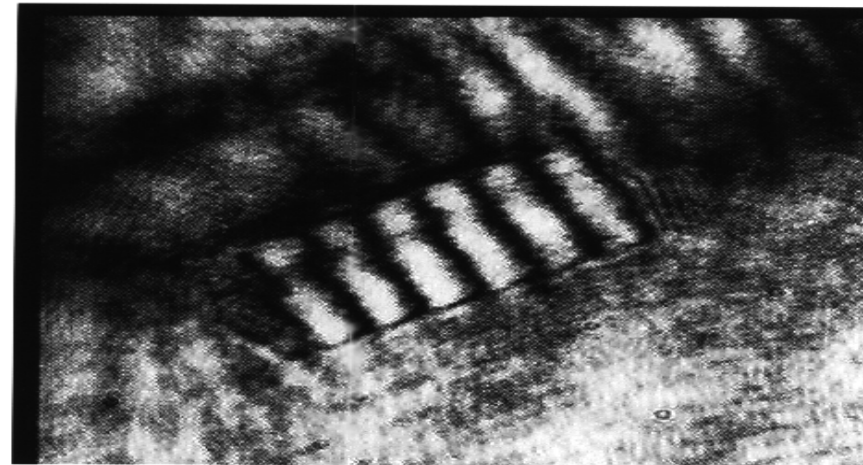
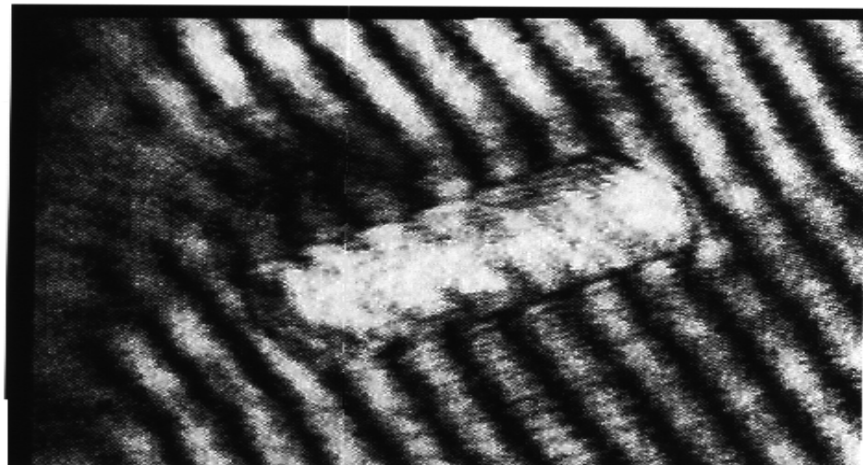

Figure MG-244 Optical Lens Cover S97-05444





Crystal with tilt



Crystal with tilt adjusted

Figure MG-245 Protein Crystal Adjusted for Viewing

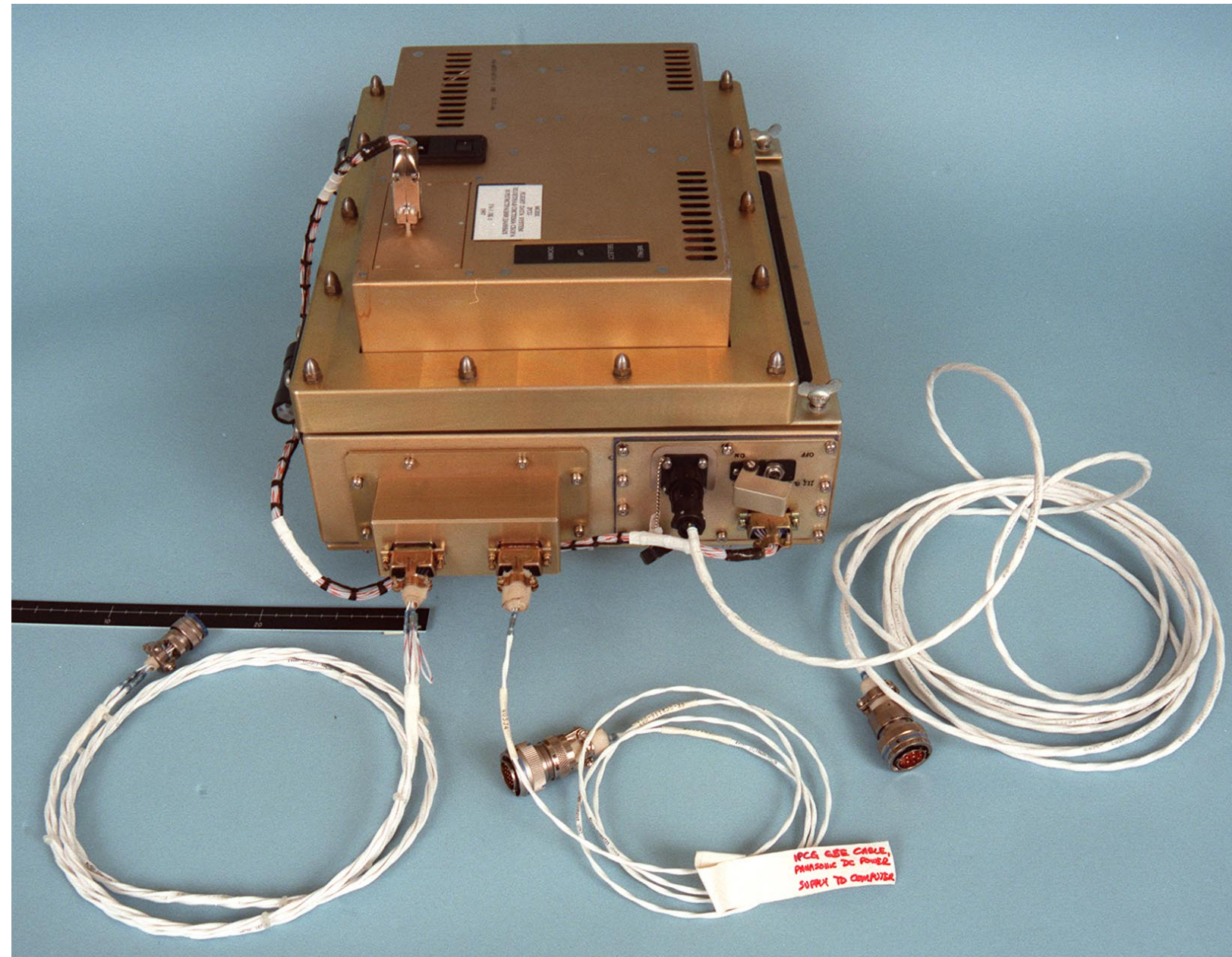

Figure MG-246 IPCG Computer, Side View Showing Power and Data Cables

S97-05273



# IPCG COMPUTER

The IPCG computer will control the liquid crystal phase shifter and collect the video data for later analysis on earth. \*

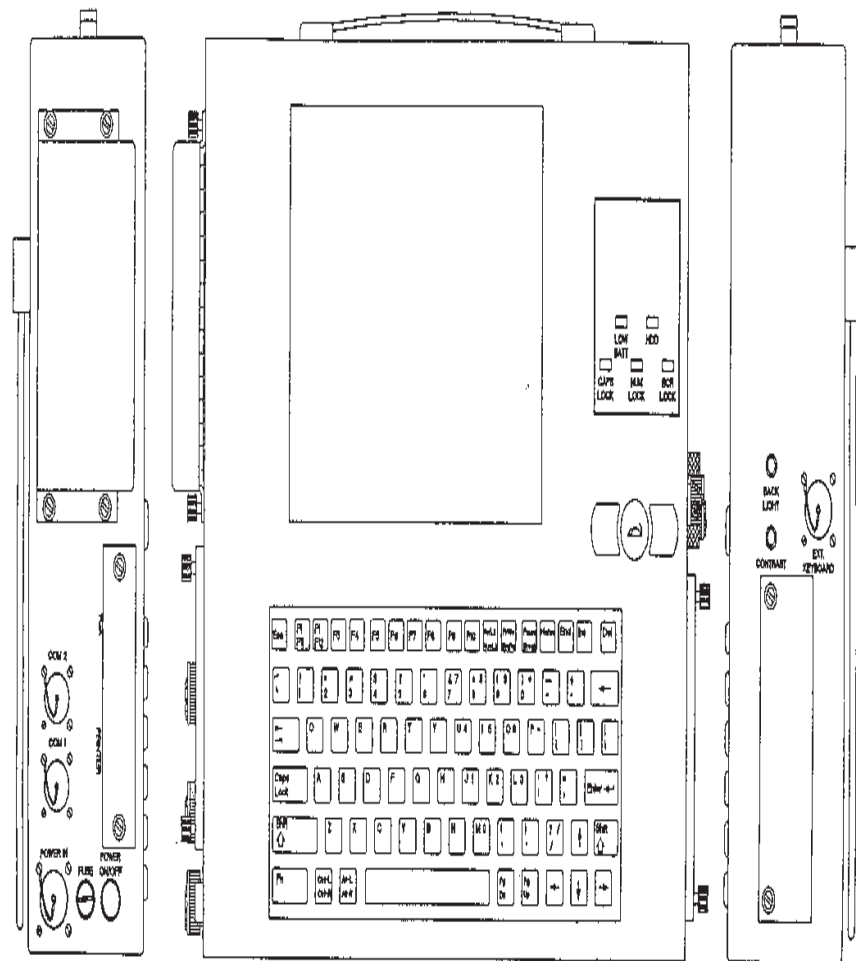

SPC 2522 MECHANICAL LAYOUT

Figure MG-247 IPCG Computer

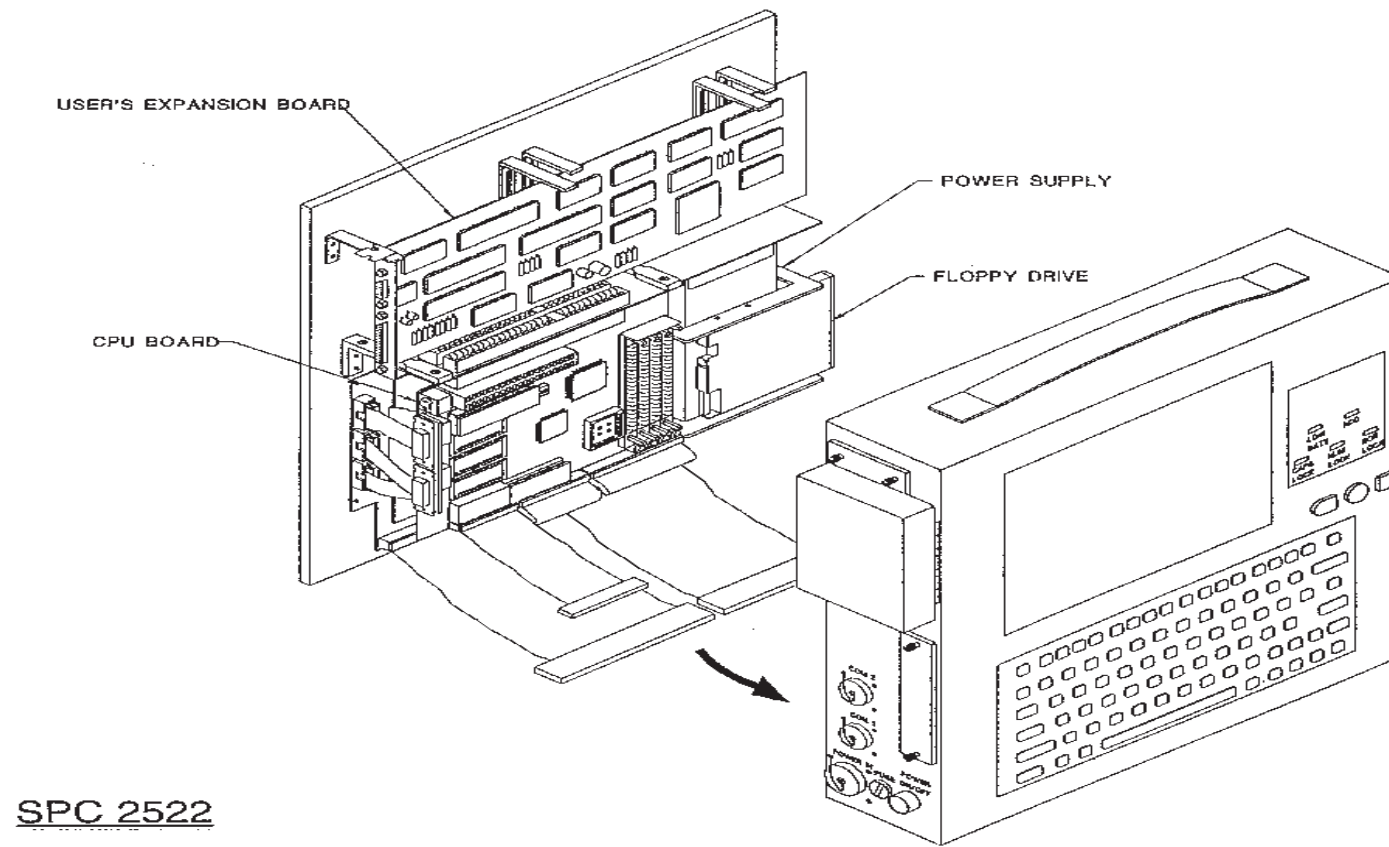

SPC 2522

Figure MG-248 IPCG Computer

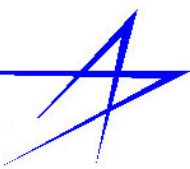

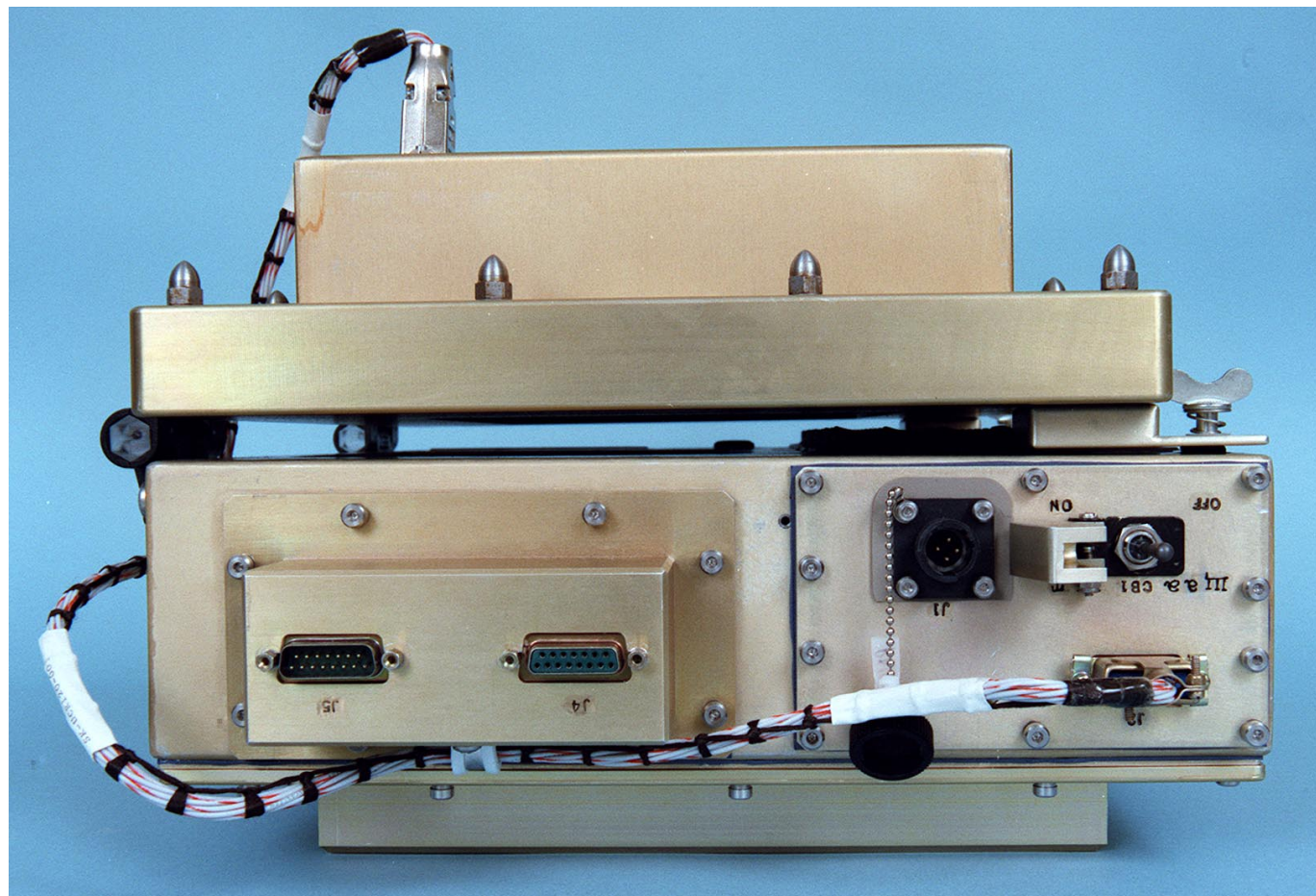

Figure MG-249 IPCG Computer, Side View Showing Power and Data Connectors S97-05272

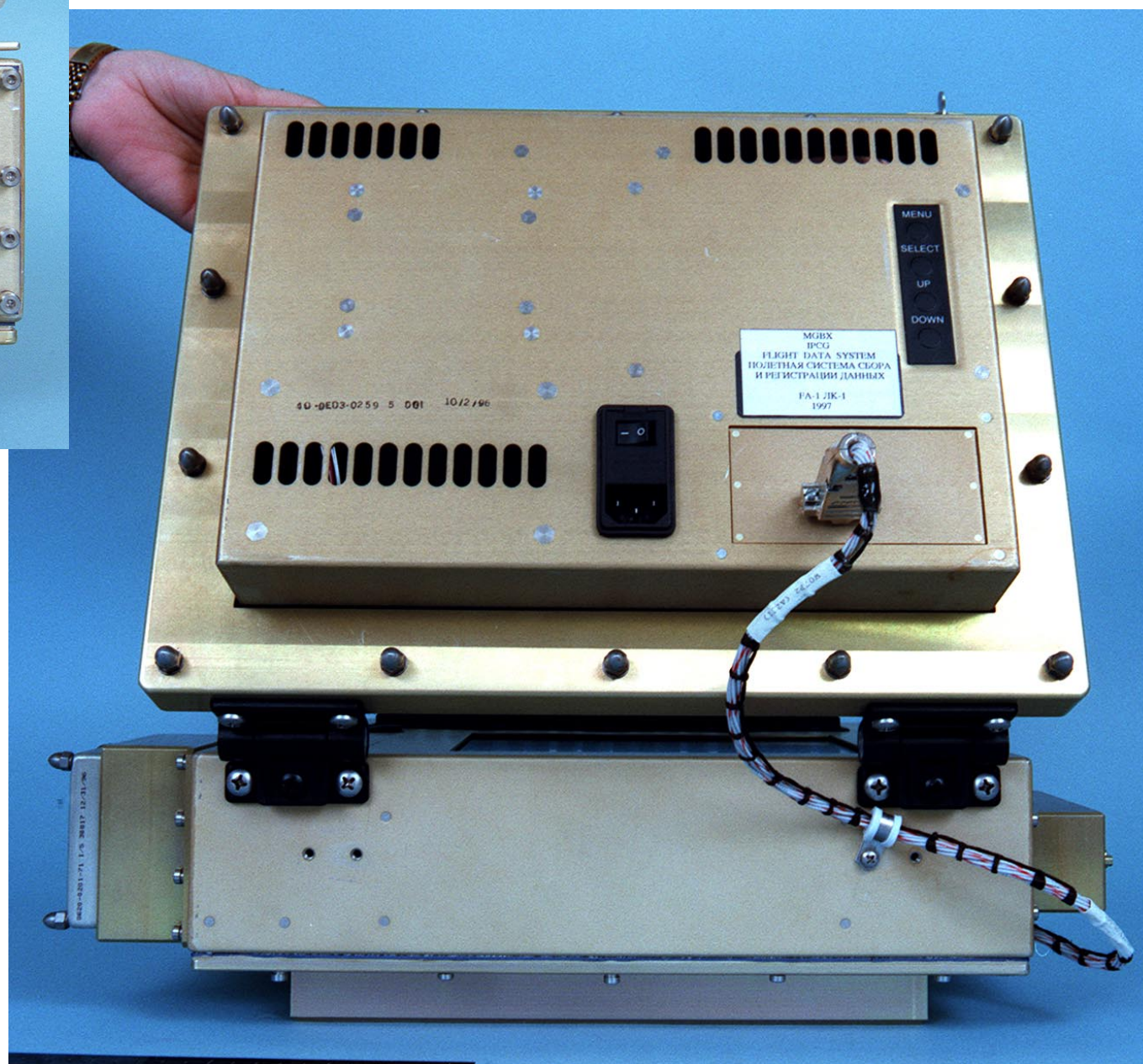

Figure MG-250 IPCG Computer, Rear View and Lid S97-05270





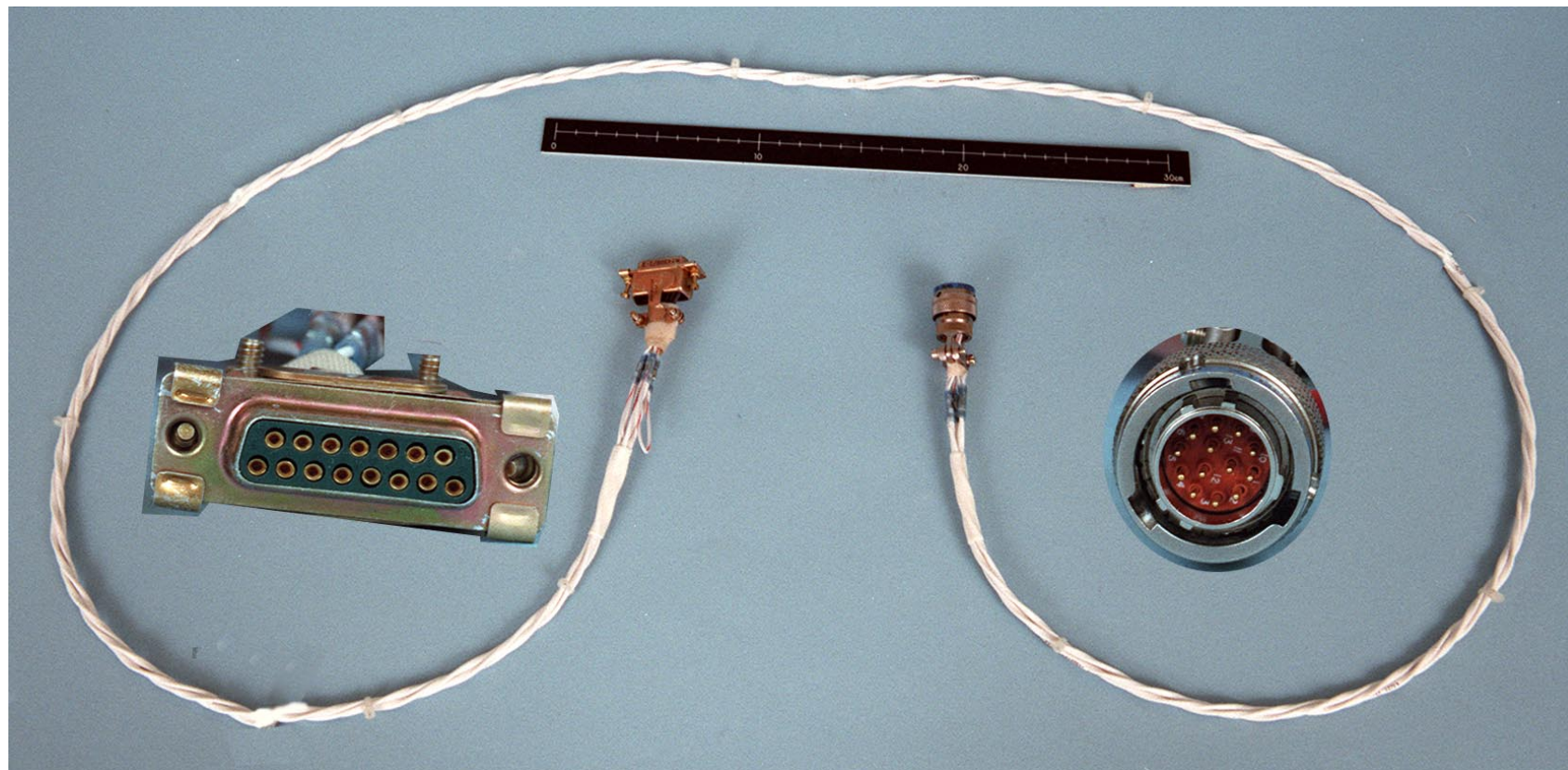

Figure MG-251 Computer Cable and Connections

S97-05267



Figure MG-253 Adjustment Knob

S97-05450

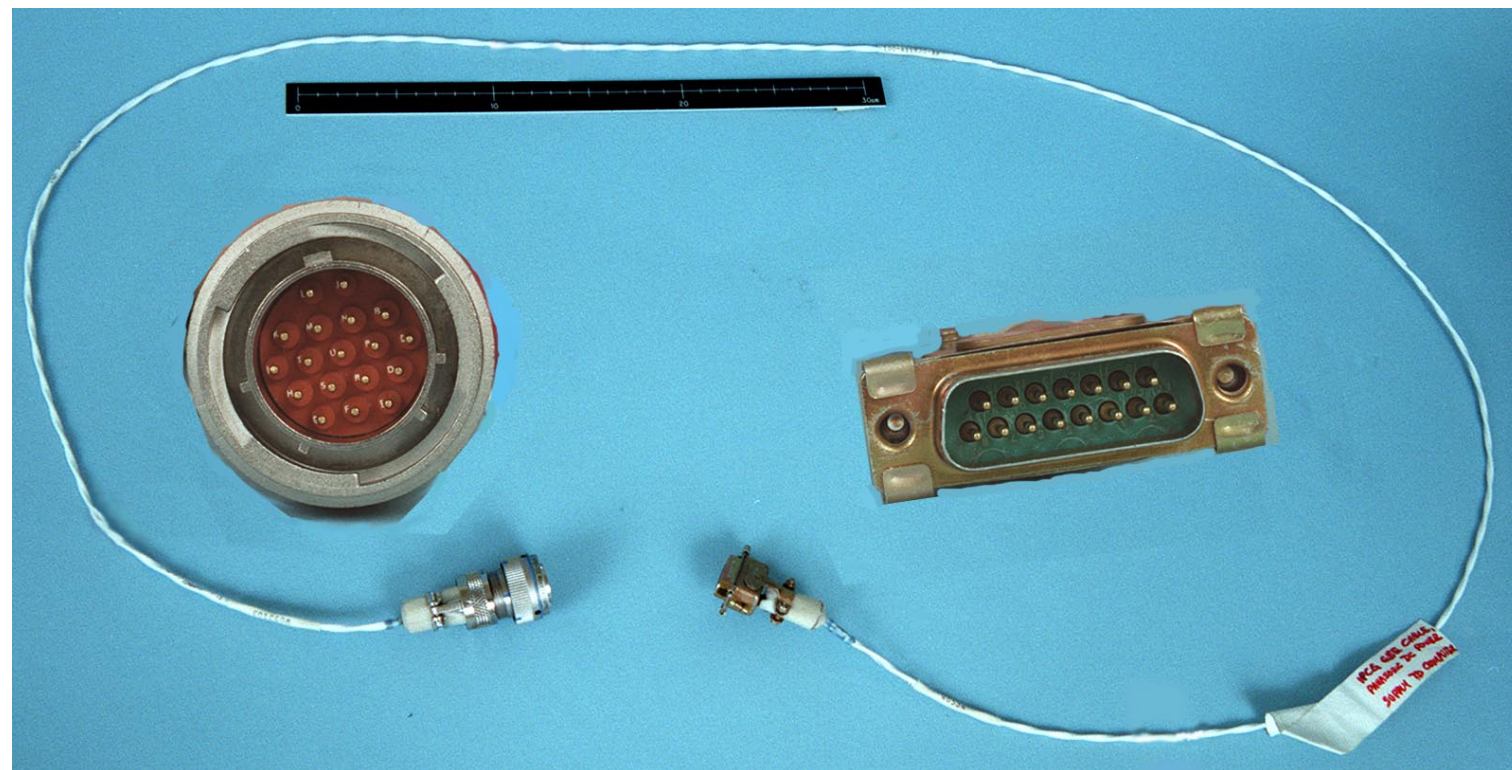

Figure MG-252 Computer Cable and Connections

S97-05269



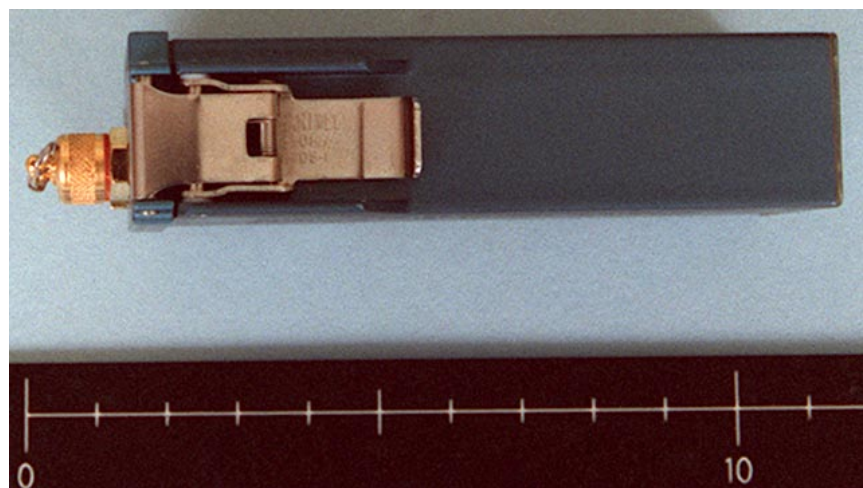

Figure MG-254 Ambient Temperature Recorder, Side View S97-05275



Figure MG-257 IPCG Case

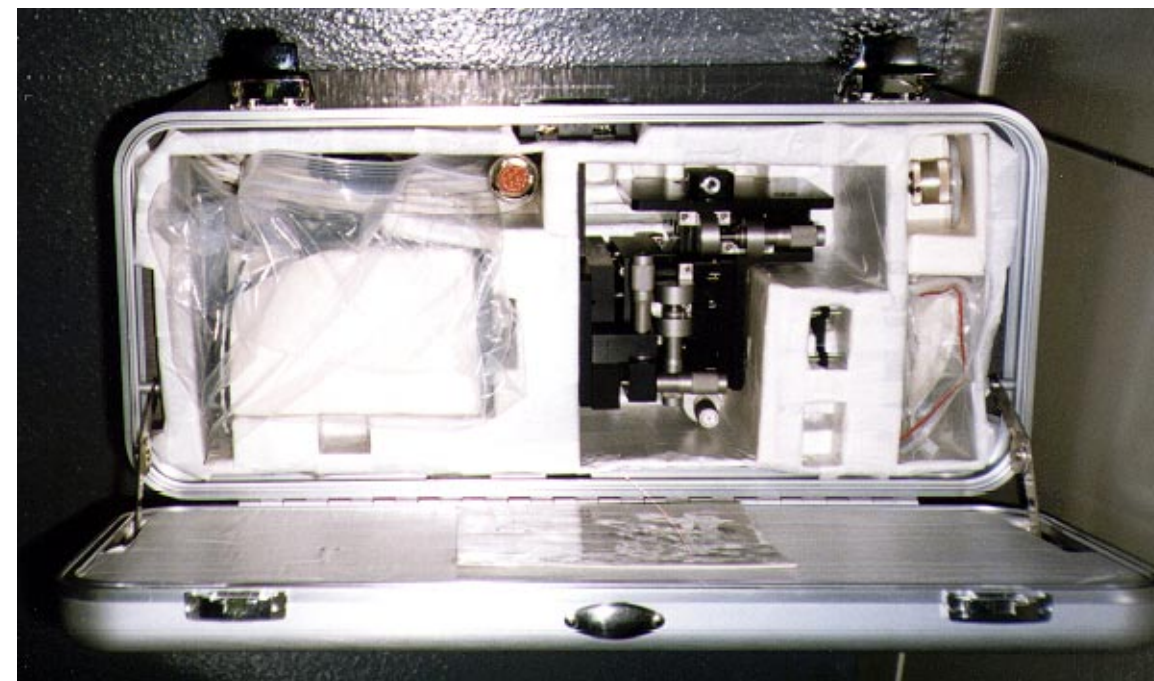

Figure MG-258 Inside IPCG Flight Case

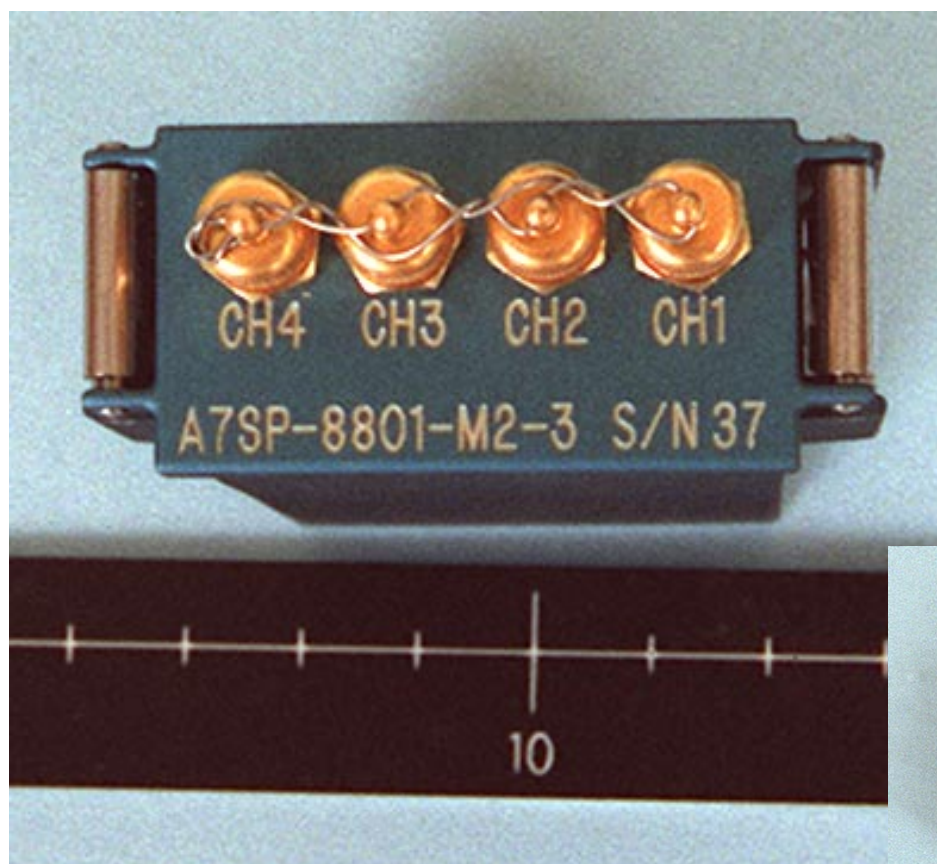

Figure MG-255 Ambient Temperature Recorder, Front View Showing Cable Connections S97-05274

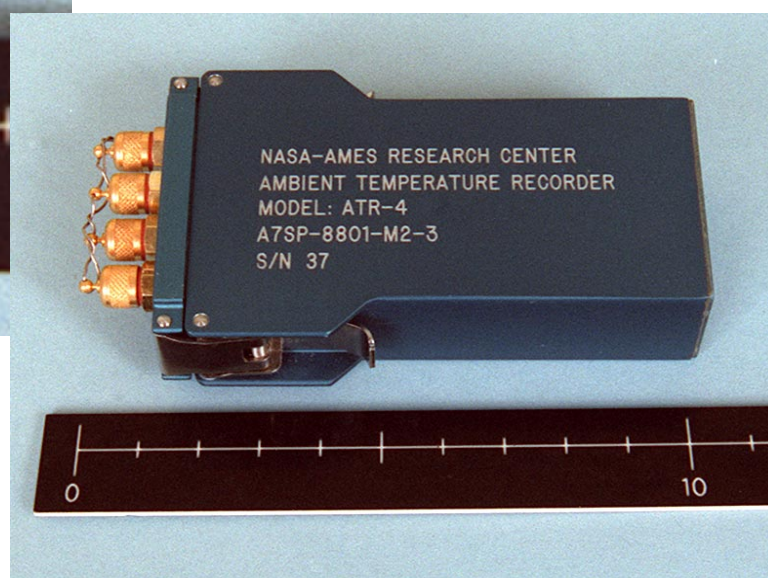

Figure MG-256 Ambient Temperature Recorder S97-05276

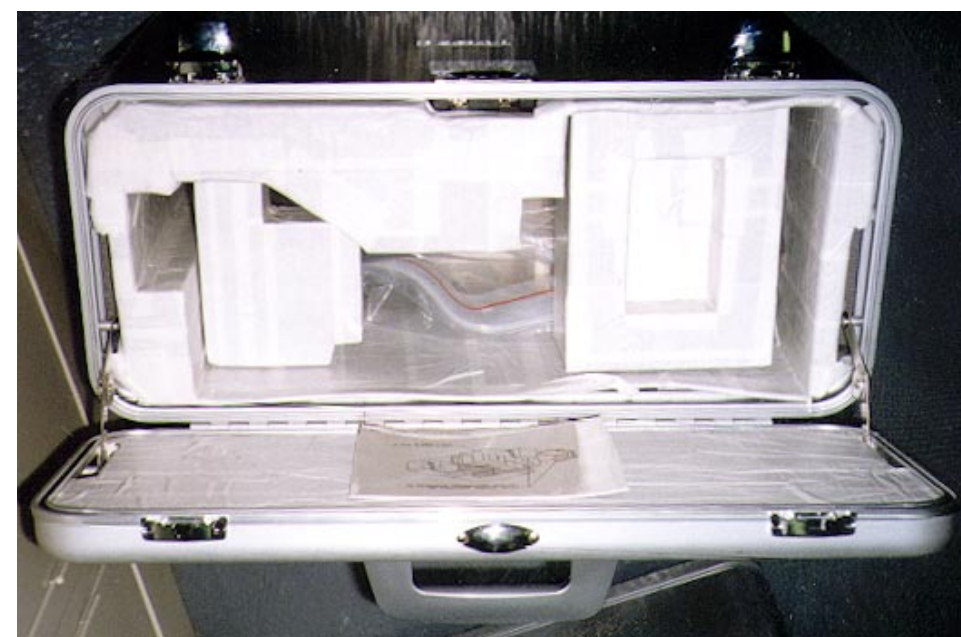

Figure MG-259 Inside IPCG Flight Case 2



# LIQUID METAL DIFFUSION EXPERIMENT (LMD) - MIM

## EXPERIMENT DESCRIPTION

The LMD Experiment will be conducted on the MIM platform. The experiment objectives are to determine the steady residual gravity and g-jitter tolerable in liquid diffusivity and to determine the influence of g-level on possible "wall effects". Additionally, tests will be made of sample restraint technologies to prevent void/bubble formation in LMD samples in microgravity. Five individual samples are to be run utilizing four different damping or acceleration profiles from the MIM.

## HARDWARE DESCRIPTIONS

### LMD EXPERIMENT UNIT (CMMR-LMD-1)

#### Mechanical Characteristics

The LMD experiment apparatus consists of an anodized extruded-aluminum box with four mounting pads extending from its bottom and a sample exchange handle, plunger and power and data connectors on the front panel. The overall dimensions of the extruded-aluminum box are approximately 45.4 x 32.4 x 23.3 cm. The four mounting pads extending from the bottom sides are 5 x 5 cm each with a mounting hole in the center of each pad with a captive fastener. The approximate mass of the LMD is 30 kg. The center of gravity is within 1 cm of all (three) midplanes.

Both mechanical operating devices, the sample exchange and plunger handle, are located on the apparatus front panel.

#### Electrical Characteristics

The LMD unit has one power input connector on the front panel, labeled as "power". Power (28 volts) will be supplied from the Microgravity Isolation Mount (MIM) via a supplied power cable (CMMR-LMD-2). The LMD has an internal DC-DC converter for conversion to +/- 12, + 5 and + 300 volts. The input power is filtered by a Interpoint FME28-461 EMI filter. All circuitry is enclosed in the anodized extruded-aluminum box.

The major electrical (circuit) components, are; 1) metal foil heater and DC heater control circuits, 2) CdZnTe detector and associated electronics power converters (+/- 12, + 5 and + 300 volts), and the detector output pulse (TTL) counters, 3) RS-232 output drivers, 4) EPROM circuitry and 5) programmable logic control circuitry.

The power draw will be less than 75 watts, 28 volts at 3 amps. Power will be drawn through pin M and returned through pin J with pin K used for ground, all on socket J-3 of the MIM flotor. Note that the pin out of the MIM flotor socket J3 is not same as the PUP pinout. Therefore, the LMD cannot be connected to the PUP using the CMMR-LMD-2 flight cable.

Audible alarm and heater reset pushbuttons and corresponding LEDs have been added to the LMD Front Panel. The alarm will sound if the oven temperature exceeds 200 °C or if the LMD Panel exceeds 50 °C. The Alarm Off pushbutton turns the alarm Off and the Heater On pushbutton resets the LMD heater.

#### Data Interface Characteristics

This equipment will interface with the MIPS-2L through the BTS data transfer cable (SEM46111488-301). There is no provision for data interfacing with any other Mir system.



Figure MG-260 LMD Power Cable 96-12661

#### POWER CABLE (CMMR-LMD-2)

The power cable is approximately 30 cm long, 3 cm diameter connectors, with a 12 pin locking stainless steel connector. The pins are wired with 20 gauge teflon coated wire encased with teflon shrink tubing over the wires.

The power cable is connected between the LMD Power connector and the J-3 Experiment Power socket on the Flotor MIM. Connector P3 on the power cable plugs into J-3 on the Flotor and connector P1 on the power cable plugs into the power connector on the LMD front panel. The cable, 1 cm diameter, 2 cm bend radius, is of such length that it cannot be connected to any other socket. No electrical characteristics. No data interface characteristics.

#### OPTICAL DISK (MIMOD-002)

This part consists of a standard optical disk. The disk will contain

instructions for the MIM acceleration profiles. This optical disk is provided by the Canadian Space Agency. No electrical characteristics. No data interface characteristics. \*



Figure MG-261 LMD Furnace Assembly 96-12662

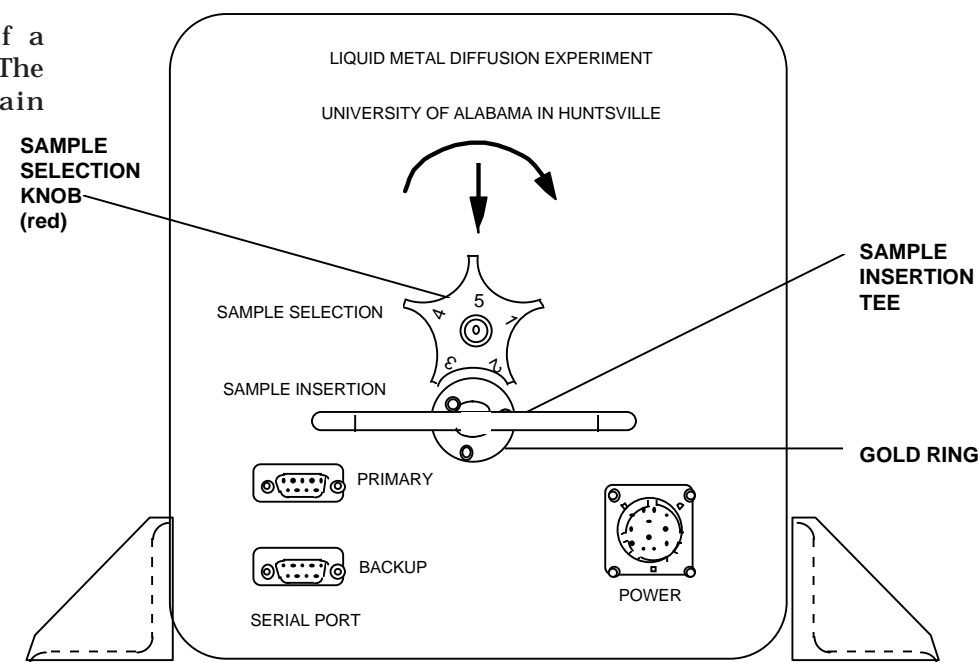

Figure MG-262 LMD Front View

**Principal Investigator:**  
Franz Rosenberger

#### LMD FURNACE ASSEMBLY

P/N: CMMR-LMD-1  
Mass: 31.80 kg  
Power: 75 W  
x, y, z: 46 x 22 x 32 cm

#### LMD POWER CABLE

P/N: CMMR-LM  
Mass: .10 kg  
Power: N/A  
x, y, z: 30 cm

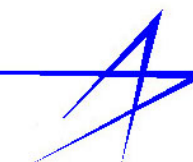

# MICROGRAVITY GLOVEBOX (MGBX) FACILITY OPERATIONS

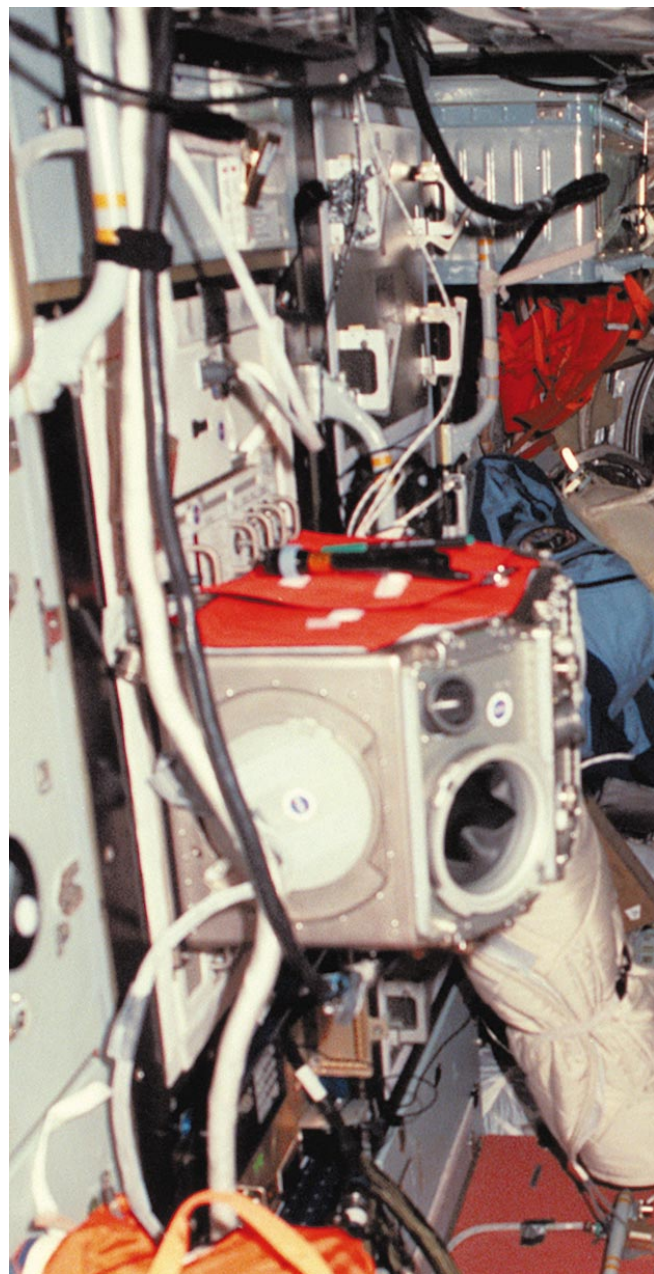

NM22-038-37

Figure MG-263 MGBX on Priroda

## EXPERIMENT DESCRIPTION

The MGBX facility provides a clean and sealed work cabinet for the preparation and performance of experiments within the laboratory environment of the Priroda module. Experiments are inserted into the unit and manipulated by gloved crewmembers. The MGBX will be used to prevent experiment materials from entering the module atmosphere and to provide basic services to experiments that will be provided by independent investigators.

The basic services supplied by the MGBX Facility to the experimenters are: electrical power, lighting, data recording, viewing (by crew), video recording, cooling, small items(s) stowage, airlock passthrough, air circulation, filtering, and gas sensing. The MGBX provides the capability to perform a variety of experiments including but not limited to fluid experiments, material experiments, and other experiments and demonstrations.

The MGBX is capable of keeping the MGBX work area at a negative pressure with reference to the ambient atmosphere. The air flowing through the work area is suitably filtered before it is returned to the crew work environment. The MGBX provides suitable internal instrumentation to monitor temperature, pressure, humidity, and gases as appropriate.

## SCIENCE OBJECTIVES

1. To provide a level of containment by providing a physical barrier between the MGBX working area and the ambient environment
2. To maintain a negative pressure within the working area during normal operations
3. To provide a working area in which to perform experiments with a window for viewing the experiments.
4. To store data on orbit to support experiment correlation with environmental status during operation of the experiments.

## HARDWARE DESCRIPTION

The MGBX is comprised of two major components: the Interface Frame (IF) and the Glovebox (GB). The IF is the structure in which the GB operates. The IF provides the structural and electrical interface to the Priroda and major support functions to the GB: electrical power, video, cooling, and data storage. The GB provides a sealed working area with circulating filtered air, penetrated by two gloves for hands-on experiment operations, and a window for viewing the experiments.

The video system is comprised of three independent video assemblies incorporated in the Data and Video Interface Drawer (DAVID); three camera heads, which mount to working area video ports and connect by cable to the DAVID; three monitor screens; and a microphone. Each of the three video assemblies comprises a video cassette recorder (VCR), camera, electronics, camera heads, and monitor screen.

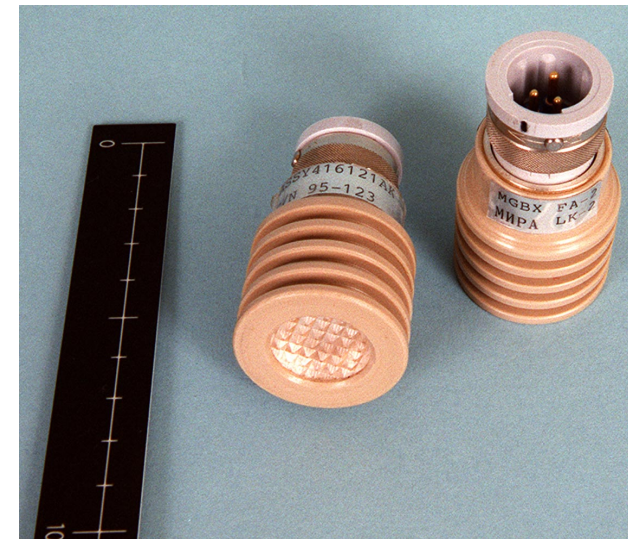

S97-05750

Figure MG-265 Replacement Lamps for Working Area (Training)



S97-06760

Figure MG-264 Glove Port Sleeves (Training)

D.I.D.

Mir Glovebox

**Principal Investigator:**  
Don Reiss, Ph.D.  
NASA/MSFC/ES76  
Project Scientist  
(205)544-7773



## GLOVEBOX

The GB is divided into four chambers: working area, Air Managing Unit, filter stowage area, and electronics module (E-Box).

### Working Area

The working area provides the following features:

- An internal volume of approximately 35 L
- A mild steel plate between 0.2 and 0.5 mm thick on its floor surface to facilitate magnetic attachment of small items
- Mechanical hardpoints for attachment of experiments requiring structural support
- Velcro pile on the working area exterior and the accessible perimeter of the Lexan window for the temporary attachment of loose objects in microgravity
- A Lexan window with approximate dimensions of 380 by 200 mm
- Gloveports for crew interface to the experiments within the working area
- Video and data feedthroughs on the main door
- Illumination, including primary illumination for the work area and a connector for a portable light source Internal Control Panel (ICP) with experiment and data connectors, air circulation switch, an air circulation control switch, and a working area inlet louver (WAIL) switch
- Video ports for camera head attachment
- Work area temperature, delta pressure to cabin, gas sensors, and humidity sensors
- A port to attach an airlock

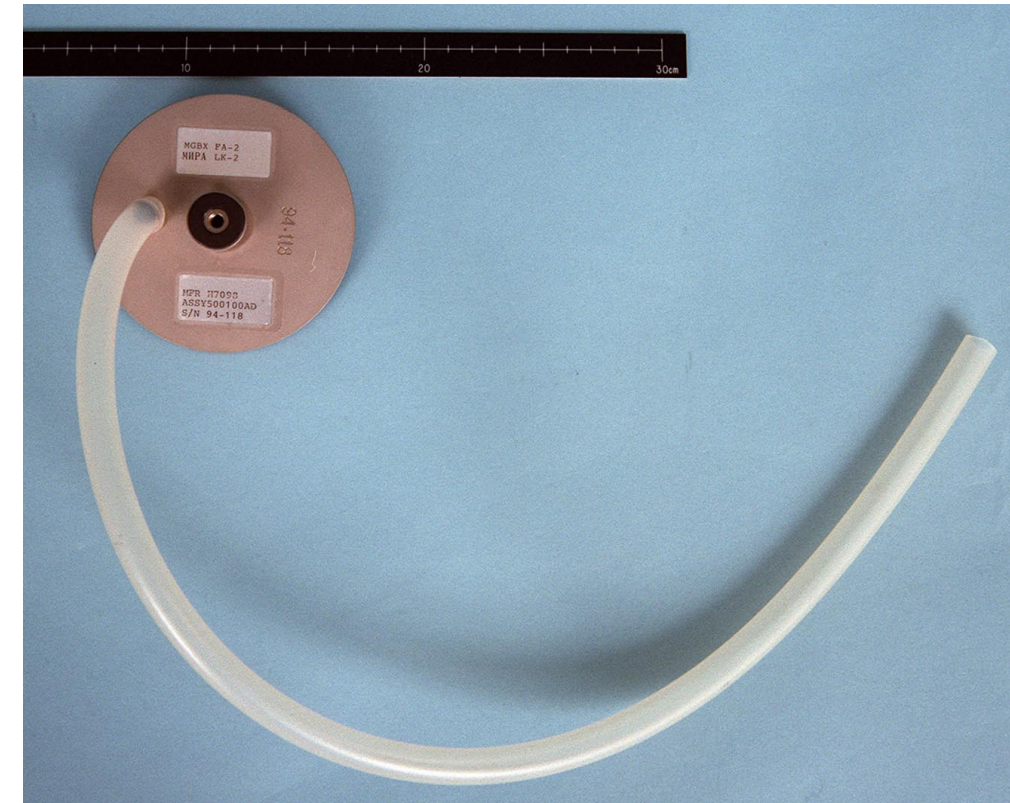

Figure MG-268

S97-06723

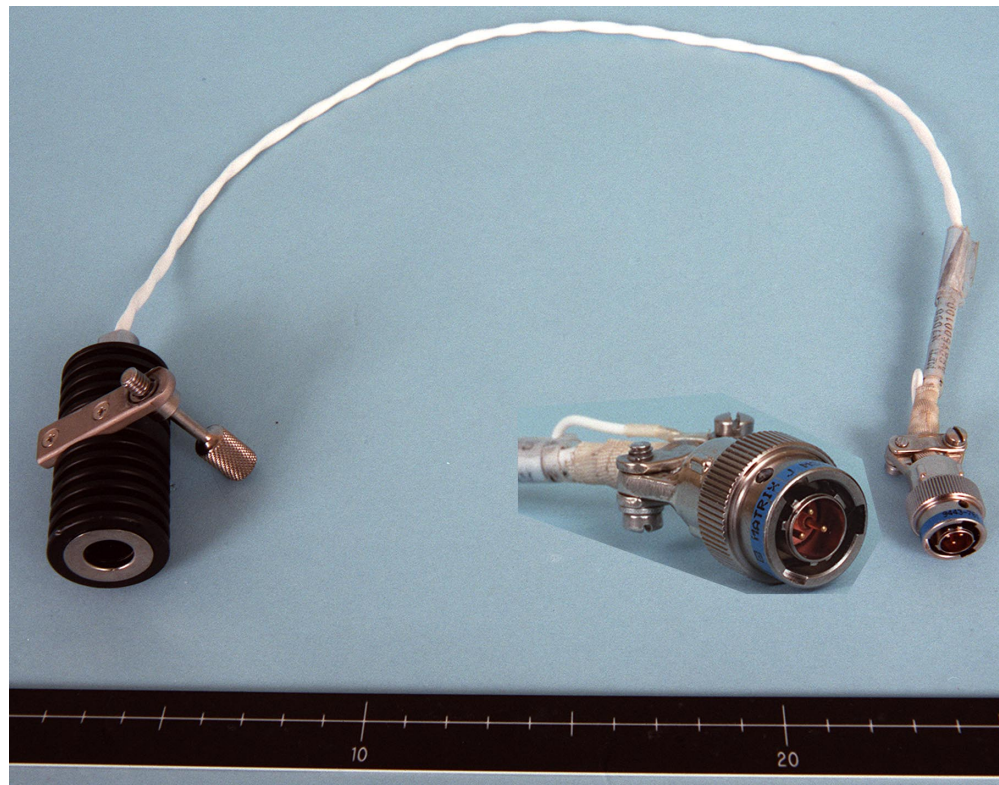

Figure MG-266 Glove Port Plugs

S97-06734



Figure MG-267 Portable Lamp

S97-06728



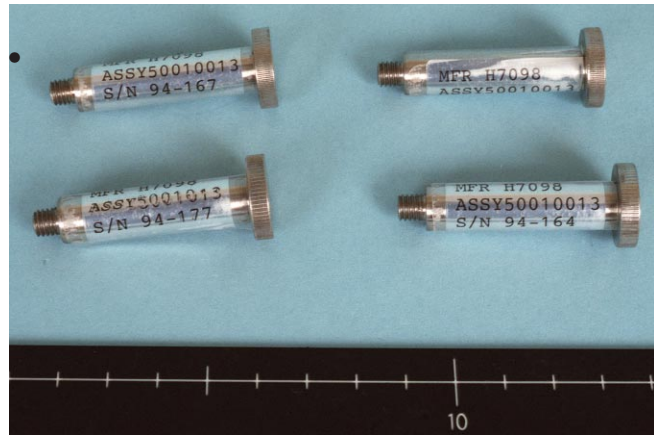

S97-06736

Figure MG-269 Long MGBX Screws

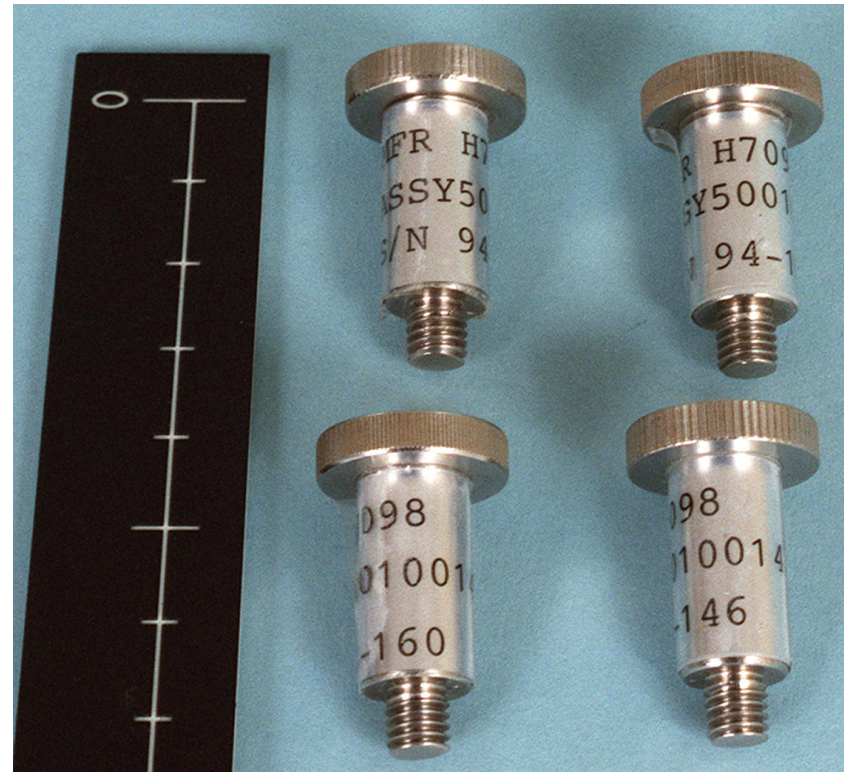

S97-06737

Figure MG-272 Short MGBX Screws

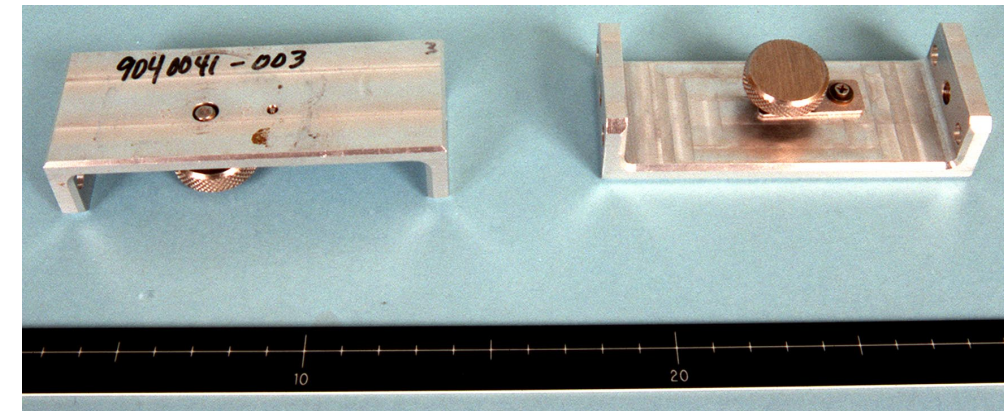

S97-06778

Figure MG-273 Mounting Brackets

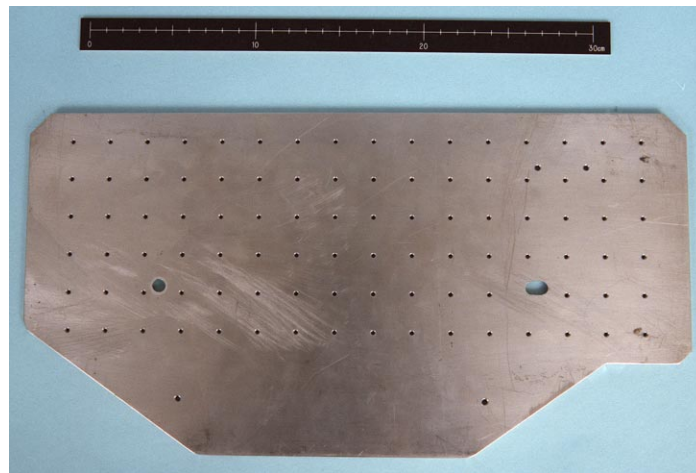

S97-06724

Figure MG-270 Baseplate Bottom

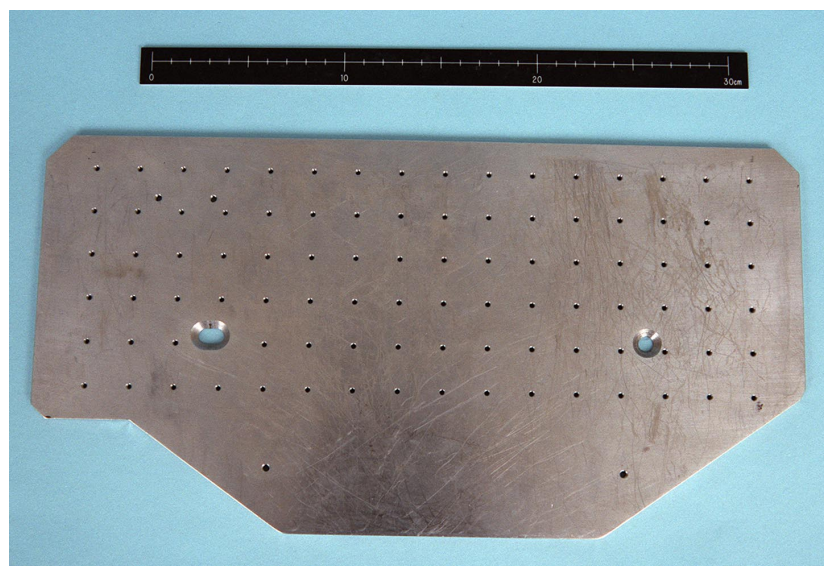

S97-06725

Figure MG-271 Baseplate Top



S97-06761

Figure MG-274 Interior Split Plates



- An interface on the outside bottom of the working area to support one accelerometer from the National Aeronautics and Space Administration (NASA) Space Acceleration Measurement System (SAMS).
- Materials, sealants, and protective coatings that are resistant to prolonged contact with spilled experimental substances or cleaning compounds.

### Working Area Illumination

Four lamps provide the primary illumination for the working area. In case of bulb failure, it is possible to change a lamp head quickly and easily on-orbit without exposing glass to the cabin environment. Lamp heads are stowed during launch and landing. It is possible to swivel each lamp head. The work area has a connector and ON/OFF switch for a portable light source. The portable light source allows the experiment to direct light at any point in working area.

### Working Area Detachment

The MGBX is designed so that the GB working area can be easily removed. The working area might need to be removed when protrusion into the aisle is a problem or when maintenance activities are required.

### Doors and Door Accessories

The GB working area provides three doors: main door, left glove door, and right glove door. It is possible to remove and replace all doors on orbit and to mount each door in a 180° inverted position. Each door provides one video port and is provided with a Velcro hook for temporary storage in microgravity.

The main door has dimensions of approximately 170 mm wide by 210 mm high. The main door provides an electrical feedthrough connector and a video feedthrough connector for experiment use.

Each of the two glove doors provides a port, which accepts a glove ring having either a glove or a sleeve. When in the upright position, each glove door video port is in the upper outer corner of the door (the left glove door is a mirror image of the right glove door). The left and right glove doors are capable of being mounted in each other's location and have dimensions of approximately 125 mm wide by 210 mm high.

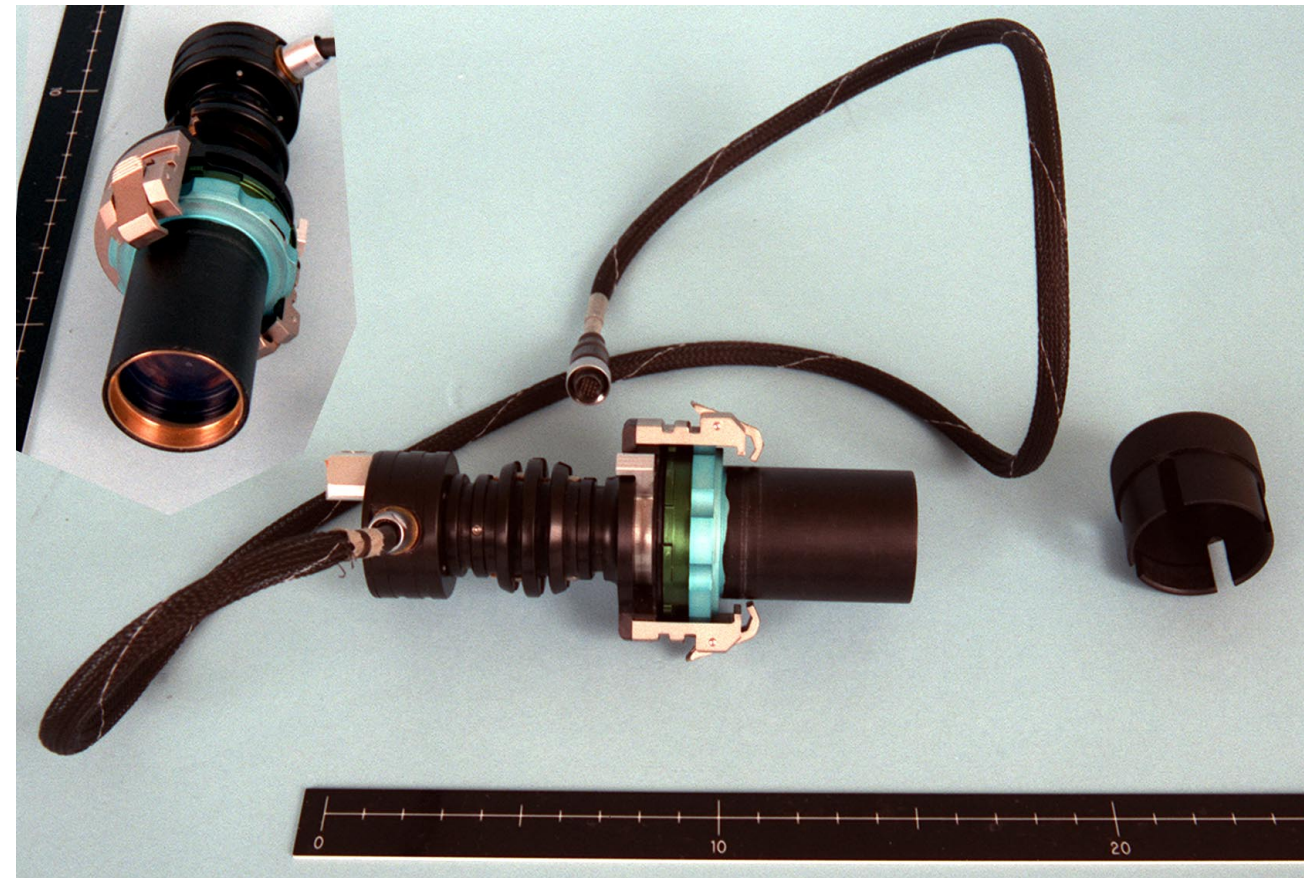

Figure MG-276 MGBX Camera

S97-06780



Figure MG-275 Russian Overlay

S97-06726

### Gloves

Each glove is mounted on a glove ring, which can be easily attached to and removed from each glove door on orbit. Gloves are mounted on the rings such that thumbs are up and palms are inward when the ring is attached to the working area. The gloves are easily removable from the glove rings to facilitate changing in case of a tear in a glove. Each glove is ambidextrous. The size of the glove is written on the glove itself.



Figure MG-277 Interior Door

S97-06754



### Glove Port Plugs

Each glove door is provided with a glove port plug which covers the glove ring during on-orbit and ground periods when the GB is not used. The glove port plug prevents dirt and small items from entering the glove, and it prevents the glove from drifting outside the GB. Each glove port plug is provided with a Velcro hook to allow temporary storage when not in use. Glove port plug removal and replacement is easily accomplished on orbit.

### Video Ports

Each video port is able to accept any of the MGBX video camera heads. When the camera head is installed in the video port, it is possible for the operator to adjust all head-mounted controls. (Green-Focus; Blue-Zoom; White-Aperture) The video port allows aiming of the cameras within the working area. The video ports prevent jiggling of the cameras when mounted.

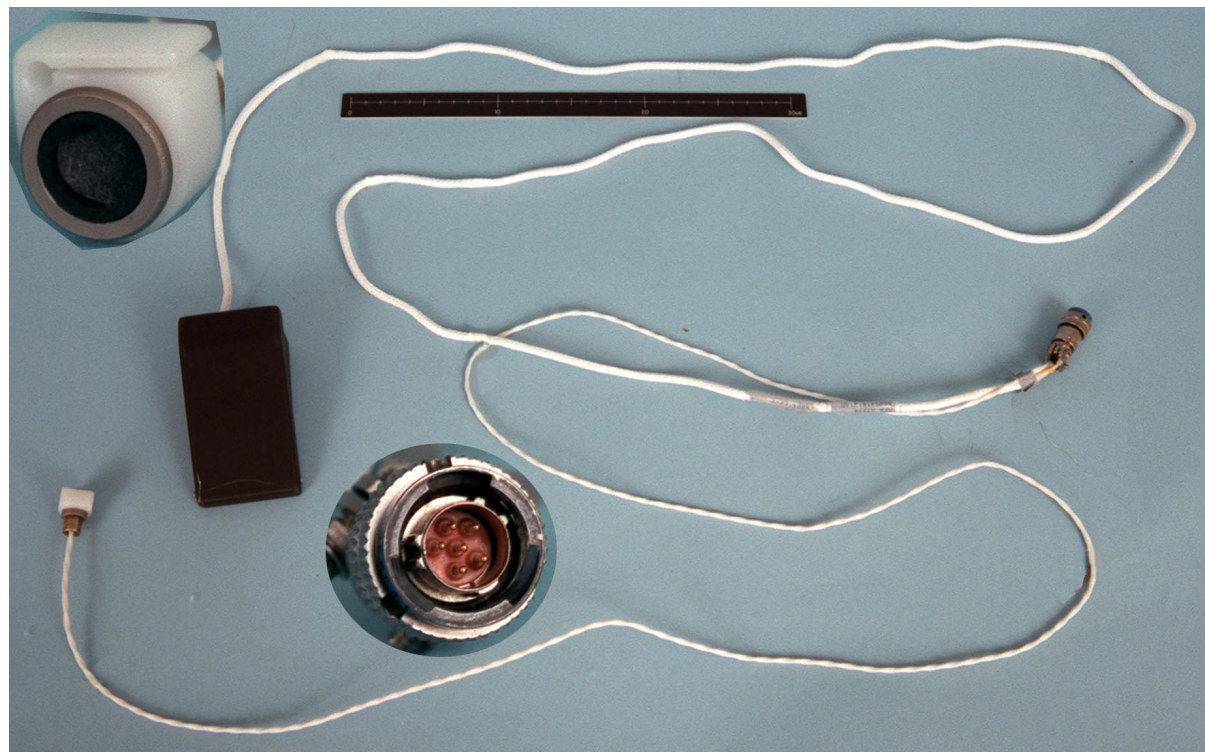

Figure MG-278 MGBX Foot Pedal

S97-06727

### Airlock

The airlock mounts to the working area Airlock Port in the same manner that a glove ring attaches to a glove door. The airlock allows the transfer of items into and out of the working area without exposing the working area directly to the Priroda Module. The airlock is launched in a stowage container and fastened to the airlock port on orbit. The design comprises a modified glove ring with metal airlock cap at the attachment end, an internal airlock cap on the work area side, a metal end plate at the free end (airlock sealing), and a cylinder of Gortex between the plates.

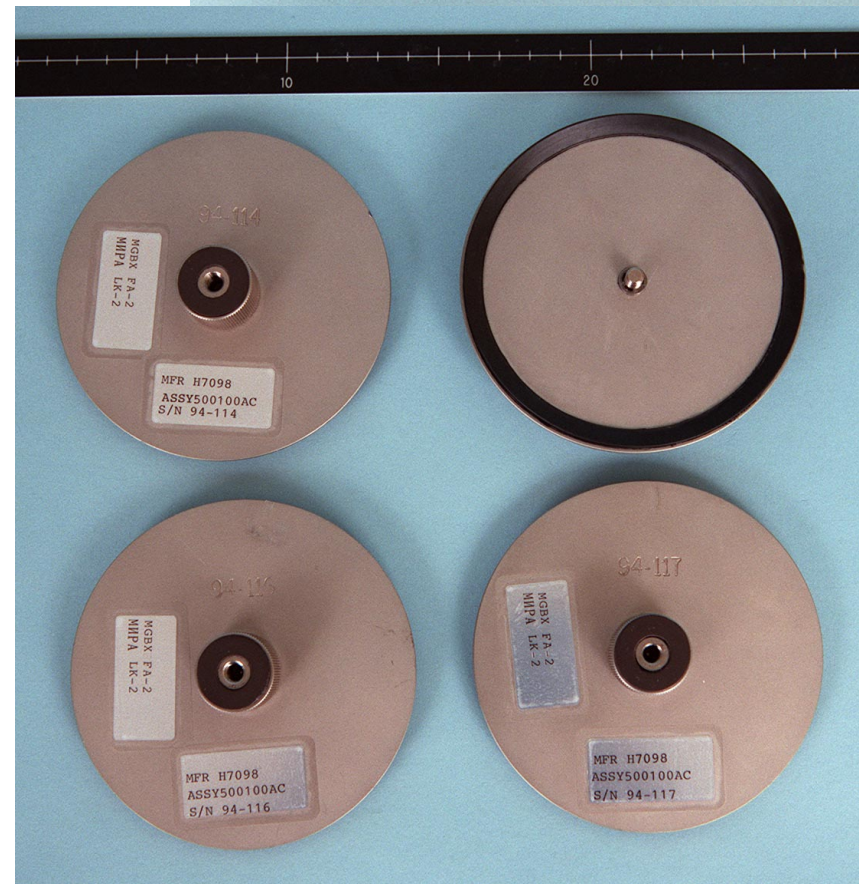

Figure MG-279 Filter Caps

S97-06762



Figure MG-280 Tools

S97-06775

### Air Managing Unit

#### GB Air Circulation Components (ACC)

The GB ACC consist of the filter area, the GB blower fan, the three-way valve, the Peltier duct, the reference outlet, the working area flappers (WAFs), and the discharge duct.





- Filter Area:

The filter area consists of the two main filter banks: the front filter bank and the rear filter bank. The front filter bank filter plate accepts four on-orbit exchangeable filters. In front of the filter area, a thin wall is installed flush with the front of the front filters to prevent objects greater than 2 mm diameter from entering cavities between filters.

The rear filter bank is redundant with the front bank in its ability to filter organic solvents and carbon monoxide. The rear filter bank consists of the rear filter plate and four rear filters, which are installed and removed only on the ground.

In order to improve the accuracy of the gas sensor readings, the front filter bank provides fins, which mix air leaving the filters and increase homogeneity of the gas mixture in that air.

- GB Blower Fan:

The blower fan draws air from the working area through the two main filter banks and directs it to the three-way valve. Safety analysis verifies that the blower fan is sufficiently contained to prevent hazards associated with rotating machinery.

- Three-Way Valve:

The three-way valve has one air inlet from the blower fan, one outlet to the Peltier duct, and one outlet to ambient air behind the GB. The three-way valve is configured to one of three positions, each corresponding to a different mode: in SEALED position, it closes off both outlets; in AIR CIRC position, it opens the outlet to the Peltier duct and closes the outlet to ambient; and in OPEN position, it opens the outlet to ambient and closes the outlet to the Peltier duct.



Figure MG-281 Interior of MGBX

S97-06768

Figure MG-282 Interior of MGBX

S97-06767



Figure MG-283 Bottom Panel of MGBX

S97-06766



- Peltier Duct:

The Peltier duct connects one outlet of the three-way valve to the duct containing the reference outlet. The GB Peltier unit mounts such that the Peltier GB side protrudes into the Peltier duct while still maintaining the leakage requirements, and the Peltier IF side protrudes rearward into the IF cooling duct.

- Reference Outlet:

To ensure that working area pressure is always below cabin pressure when the blower fan is switched ON, the high pressure side of the fan (downstream of the three-way valve and the Peltier) is referenced to cabin pressure by means of an outlet connected to the Priroda called the reference outlet. The reference outlet allows small amounts of air to move into and out of the circulating air to compensate for small changes in working area volume such as changes caused by hand movements. The reference outlet is screened so that objects of greater than 1 mm diameter cannot enter or exit.

The reference outlet connects to the cabin via the volume between the GB E-Box ceiling and the IF upper chamber. This volume, called the reference chamber, contains a labyrinth to minimize flow turbulence. The volume of air contained between the reference outlet and the cabin is at least the total volume of two GB gloves, in order to minimize mixing of cabin air and GB air due to glove movements.

- Working Area Flappers:

The WAFs prevent toxic materials from entering the cabin via the discharge duct in the event that the three-way valve is not sealed and the blower switches off while there are toxic substances in the working area. The WAF consists of two banks of two parallel non-return valves in series.

- Discharge Duct:

The discharge duct connects the WAF outlet to the working area inlet just behind the WAIL.

- Working Area Inlet Louver:

The WAIL covers the inlet to the working area and can be adjusted to provide variable flow resistance and, thus, variable working area under pressure.

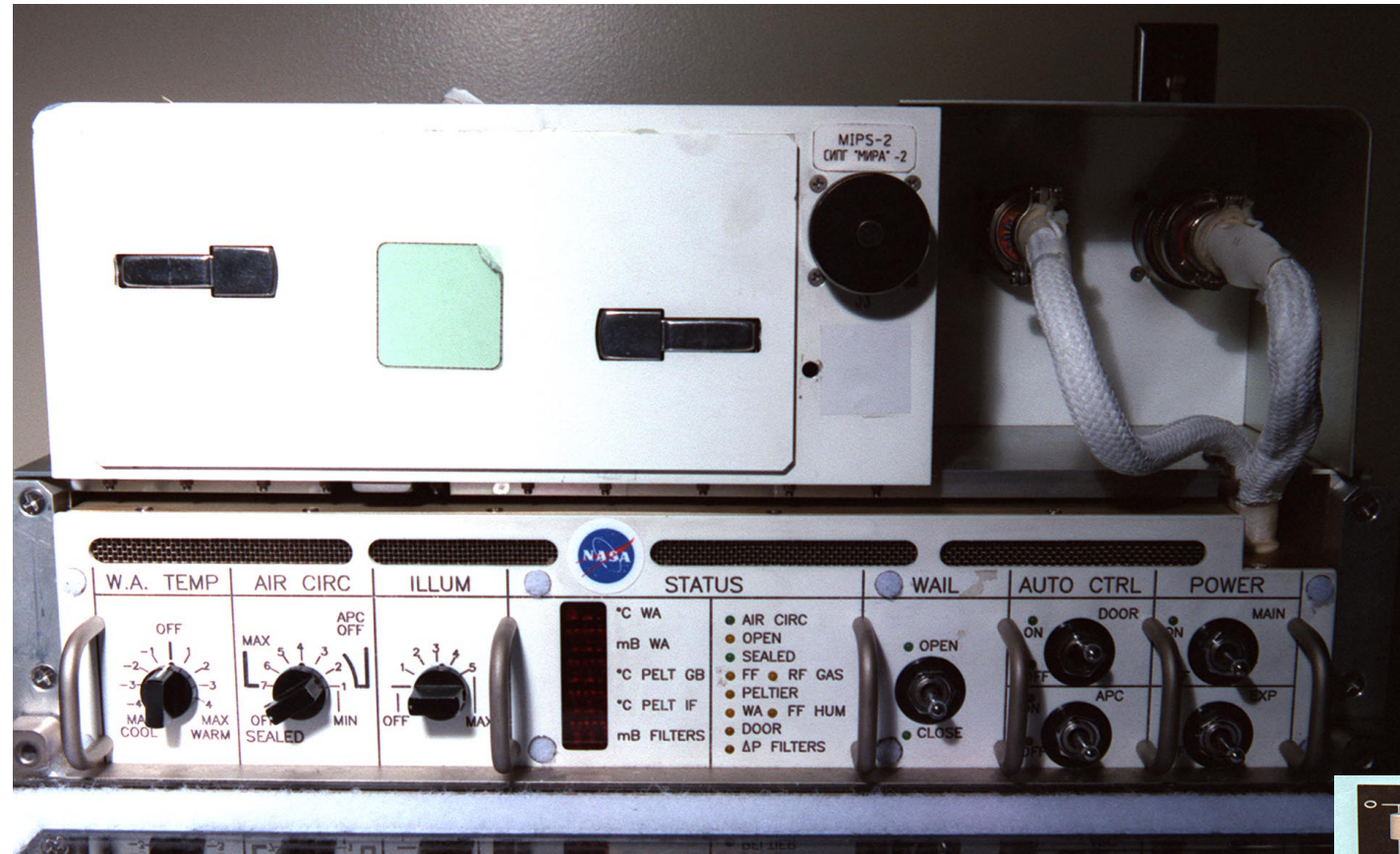

Figure MG-284 Panels Above the MGBX

S97-06765

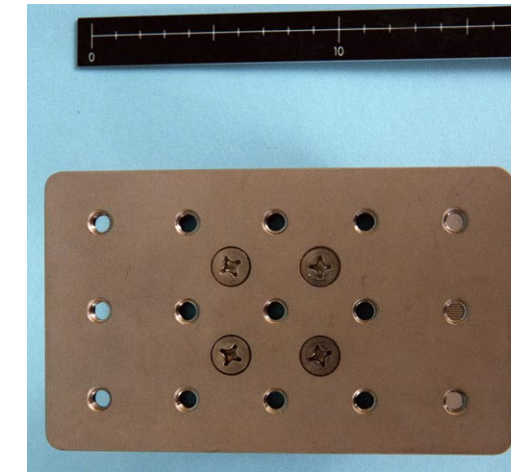

Figure MG-286 Lab Jack Bottom

S97-06730

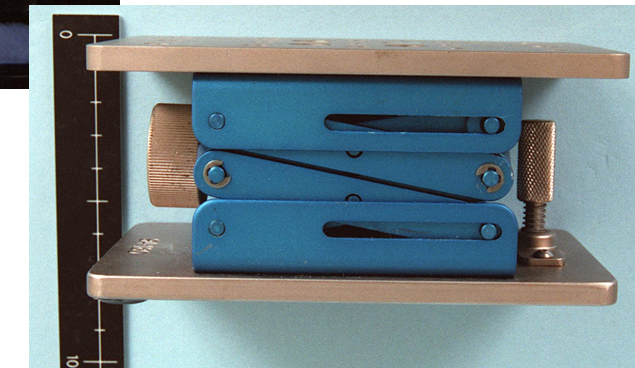

Figure MG-287 Lab Jack Fully Closed

S97-06733

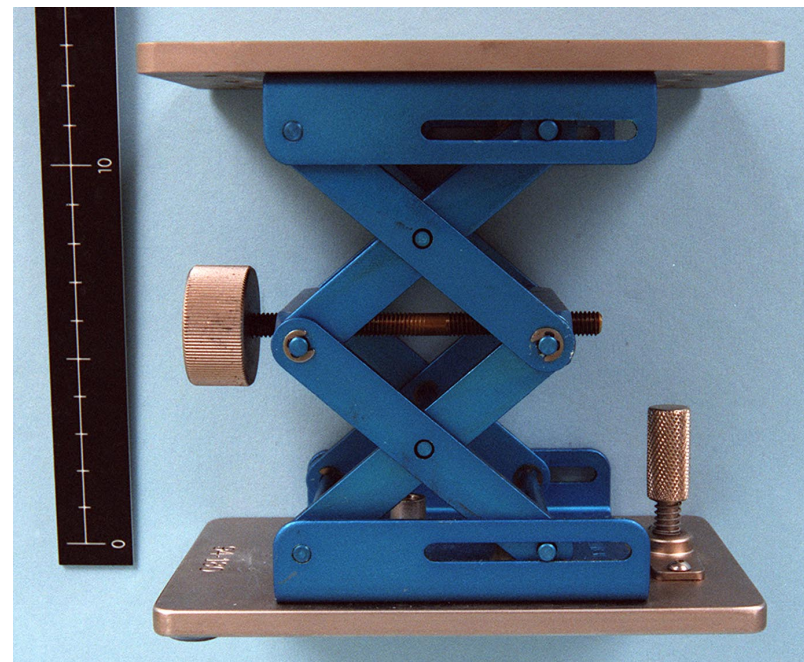

Figure MG-285 Lab Jack Fully Extended

S97-06731

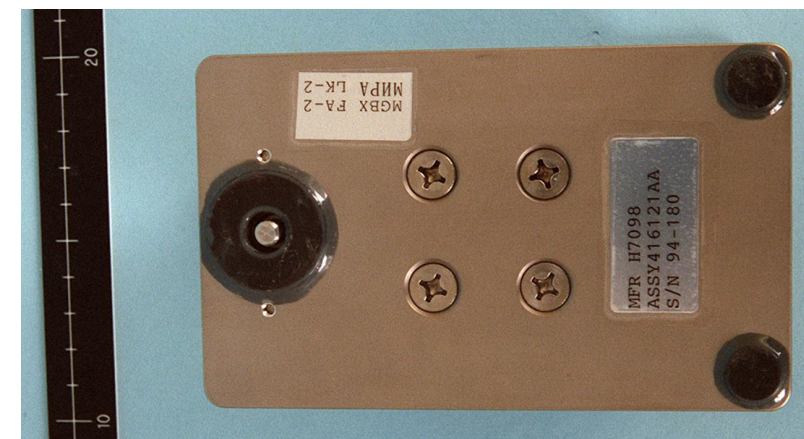

Figure MG-288 Top of the Lab Jack

S97-06729



• Stowage Area:

The MGBX provides a stowage area of total volume at least 5.5 L, which is directly accessible from the working area. The stowage area is covered by a door when not in use to prevent small objects from entering or exiting. The door remains in its last position (open or closed) in microgravity until moved again by the operator.

To prevent the potential buildup of gases in the rear of the stowage area, a vent allows a stream of filtered air from the discharge duct to enter and flush the stowage area.

**Electronics System**

*CMP*

The CMP, which is located above the work area at the front of the E-Box, provides the crew with switches, lights, and LED displays.

The CMP is used to control the MGBX lighting system, experiment power system, air-circulation system, and cooling system. The CMP is used by the crew to monitor the work area temperature, air-circulation pressure, power status, and mode status.

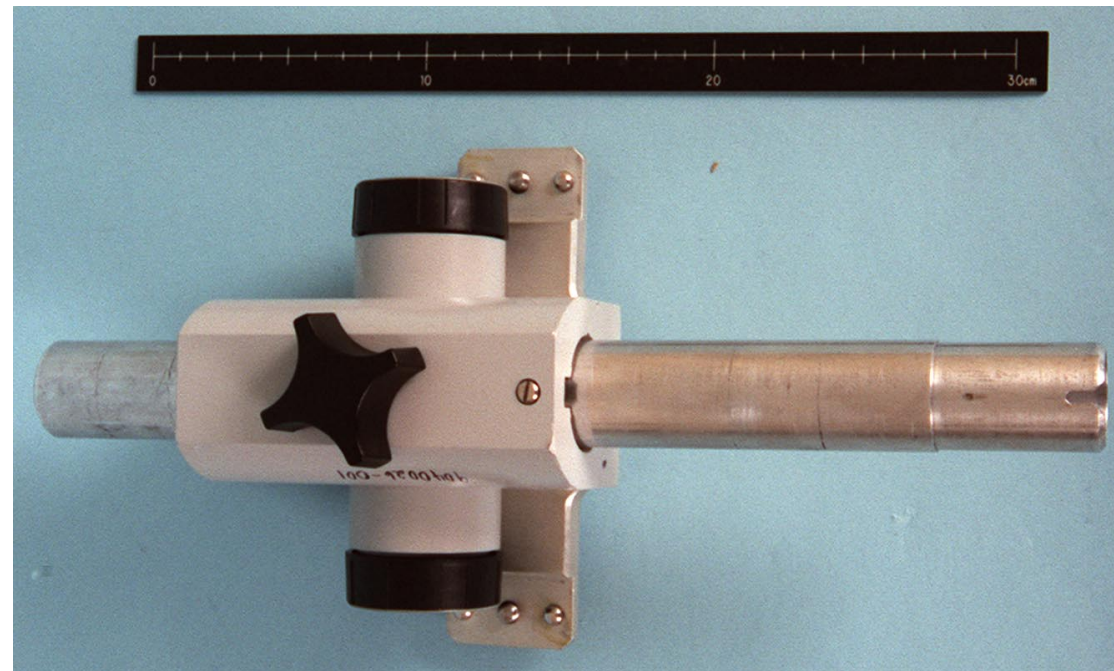
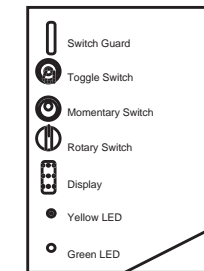
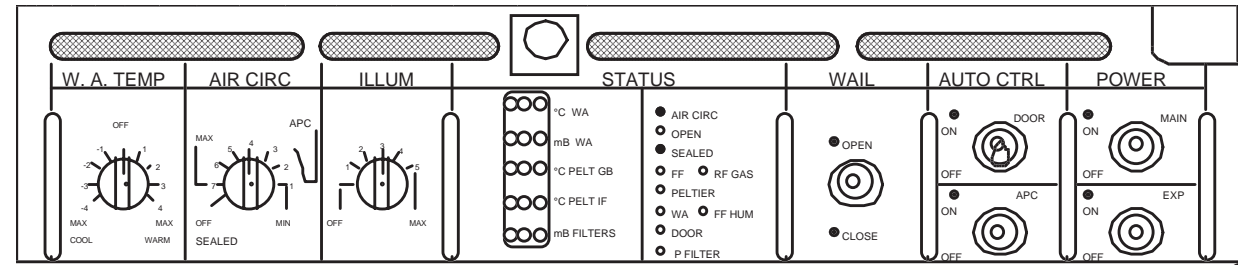

S97-06771

Figure MG-290 Post Adapter Assembly Front

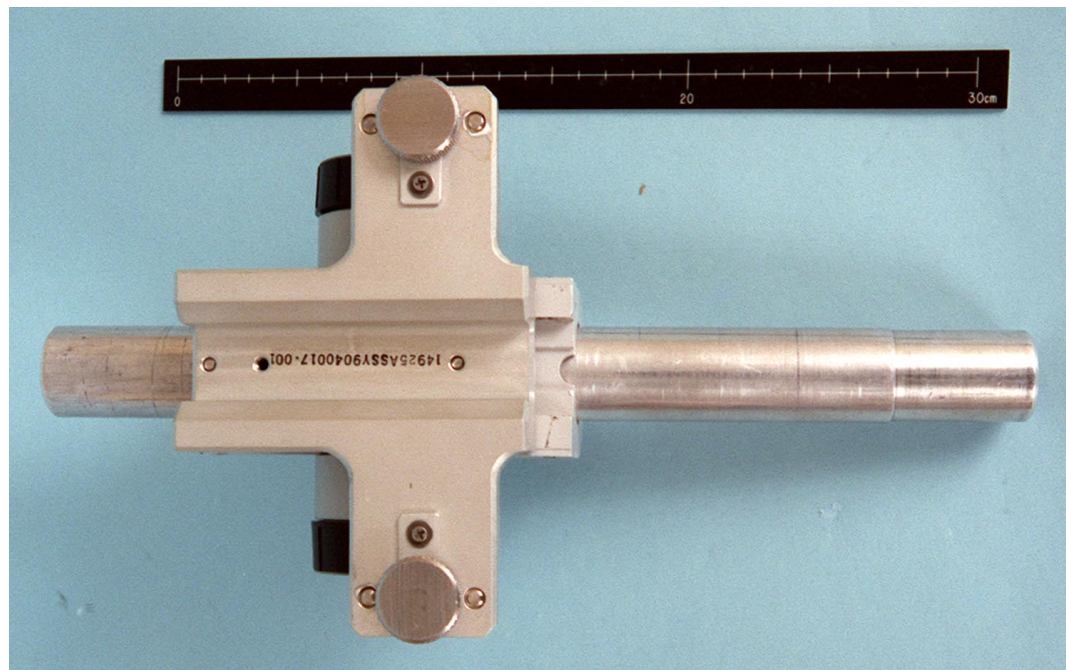

S97-06772

Figure MG-289 Post Adapter Assembly Back

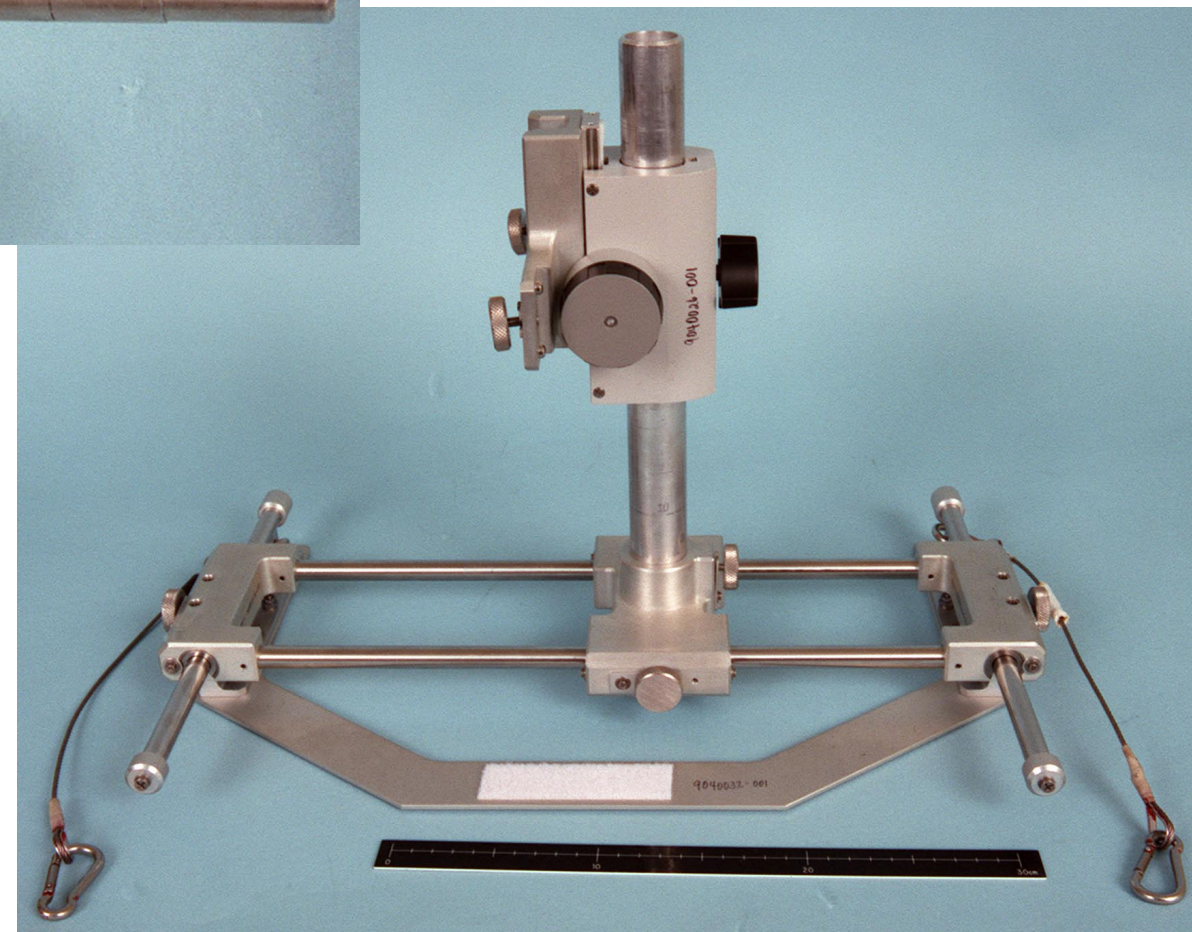

S97-06774

Figure MG-292 Translation Table and Post Adapter Assembly



**TABLE MG.6  
GB CMP SWITCHES**

SWITCH LABEL	SWITCH TYPE	FUNCTION
ILLUM	Rotary	Clockwise (CW): Increases Working Area Light Counterclockwise (CCW): Decreases Working Area Light Full CCW: Lights OFF
AIR CIRC	Rotary	Full CCW: Blower Fan OFF 1st CW Setting: Blower Fan Full Power CW: Decreases Blower Fan Power
W.A. TEMP	Rotary	Full CW: Peltier Full Power to WARM Working Area OFF (middle position): Peltier Power OFF Full CCW: Peltier Full Power to COOL Working Area
DOOR	Toggle	OFF: Door Sensors are inactive so that Air Circulation will continue with door(s) unlatched. ON: Door Sensors are active and will interrupt Circulation if a door is unlatched.
APC	Momentary	OFF: "Auto Pressure Control" in OFF so GB will not switch to open mode if GB fan is on and work area pressure is <1 mbar. ON: "Auto Pressure Control" in ON so GB will switch to OPEN mode if GB fan is ON and working area pressure is <1 mbar
MAIN	Momentary	ON: GB Main Power ON OFF: GB Main Power OFF
EXP	Momentary	ON: Experiment Relay closes and +28 V primary power is fed through the ICP "EXP Power" Connector OFF: Experiment Relay opens and no power is fed through to ICP "EXP Power" Connector
WAIL	Momentary	OPEN: WAIL full Open or moving toward full Open position CLOSED: WAIL min Open or moving toward min Open position Center Position: WAIL not moving

**MGBX Adapters**

The glovebox also contains several adapters to facilitate photographic equipment and various experiments. These include:

- Lab Jack
- Microscope Adapter
- Translation Table
- Camera Adapter Assembly

**INTERFACE FRAME**

**IF Electrical Power Distribution System (EPDS)**

The IF houses the EPDS in the lower and middle chambers. The power converter unit is located on the rear wall of the middle chamber. The electromagnetic interference filters and miscellaneous other electronic components are located in the lower chamber on the bottom plate underside. Grommet lined holes in the upper and lower plates allow feedthrough and are restrained using cable ties and saddle clamps of P-clamps mounted to the structure.

**TABLE MG.8  
GB YELLOW CAUTION LED STATUS**

LED LABEL	LED SIGNIFICANCE
OPEN	ON: Three-way valve in Open Position and GB Fan max speed command issued OFF: Three-way valve not in Open Position or GB Fan not max speed command not issued
DOOR	ON: At least one GB Door open OFF: All GB Doors closed
GAS 1	ON: More that 1000 parts per million (ppm) of Carbon Monoxide (CO) detected after first filter bank OFF: Less than 1000 ppm detected after first filter bank
GAS 2	ON: More that 1000 ppm of CO detected after second filter bank OFF: Less than 1000 ppm detected after second filter bank
DP FILTERS	ON: DP across both filter banks more than 11 or less than 3 MB OFF: DP across both filter banks between 3 and 11 MB
PELTIER	ON: Peltier Temperature GB side or IF side exceeds 73 °C OFF: Peltier Temperature GB side and IF side under 73 °C
HUMIDITY FILT	ON: Relative Humidity between first and second filter banks greater than 70 percent (measurement accuracy ±5 percent) OFF: Relative Humidity between first and second filter banks less than 70 percent
HUMIDITY WA	ON: Relative Humidity in Working Area greater than 70 percent OFF: Relative Humidity in Working Area less than 70 percent

**TABLE MG.7  
GB GREEN LED STATUS**

LED LABEL	LED SIGNIFICANCE
MAIN (near Main switch)	ON: Indicates the +28 Vdc (nominal) is applied to the GB OFF: Indicates that +28 Vdc is not applied to the GB
EXP (near EXP switch)	ON: Indicates that +28 Vdc (nominal) is applied to EXP OFF: Indicates that +28 Vdc (nominal) is not applied to EXP
SEALED	ON: Three-way valve in Sealed Position OFF: Three-way valve not in Sealed Position
AIR CIRC	ON: Three-way valve in Air Circ Position OFF: Three-way valve not in Air Circ Position
APC	ON: Open Mode Safety Switched On OFF: Open Mode Safety Switched Off
DOOR ON	ON: Door Sensors Enabled OFF: Door Sensors Disabled
WAIL Open	ON: WAIL full Open OFF: WAIL not full Open, not in motion FLASHING: WAIL moving
WAIL Closed	ON: WAIL minimum Open OFF: WAIL not minimum Open, not in motion FLASHING: WAIL moving



## IF Air-Circulation System

The IF houses the air-circulation system that provides cooling air for the GB Peltier unit. Two fans located in the lower chamber, working in parallel, pull air from the upper chamber through the GB Peltier and blow air into the lower chamber where it then passes out through screened openings to the Priroda air-circulation system. The fans are mounted to the fan inlet duct, which funnels air to both fans from the GB Peltier lower duct located on the opposite side of the lower plate.

## DAVID

The IF houses the DAVID in the upper chamber. The DAVID interfaces with the IF via Delrin rails, which allow low friction insertion on orbit. A latch retains the DAVID in position. The upper chamber houses the DAVID umbilical cable tube. The tube restrains the umbilical coil cable for power and data transmittal to the DAVID. The tube and coil cable are launch installed so mounts are designed for flight loads.

See Table MG.11 for DAVID front panel switches and Table MG.10 for DAVID LEDs.

Air entering the GB passes through the GB upper duct mounted to the underside of the IF upper plate with the same sealed interface. Air enters the upper duct from a hole in the upper plate. Air passes through the upper chamber after entering through a screened opening in the IF upper front. Air enters through a screened opening on the DAVID front panel and passes out the back of the DAVID to provide heat removal for the video equipment. Four thermostats are located in the lower chamber of the IF near the front panel. These thermostats measure structure temperature and shut off all power coming into the MGBX, except IF fans, in the event of overtemperature. When the thermostats cool to the recovery temperature, the MGBX power is manually turned back on.

## IF to GB Interface

The GB is restrained in the IF by two interfaces. A flange on the GB interfaces with the IF front flange. The IF front flange is a spacer bolted on each side of the IF. These two spacers contain the inserts for bolting to the GB. The Middeck spacer does not have the wide flange and simply bridges the gap between the IF and GB.

The second restraint interface is two 10 mm nominal diameter shear pins. The pins are located on the IF side and interface with the rear of the GB to carry side loads in the y- and z-axes.

The IF air-circulation system has two interfaces to the GB, which allow air to circulate through the GB Peltier unit. One of each of the interface points are located on the upper and lower air ducts and mate with ducts located on the GB. The connection is automatically sealed when the GB is fully inserted into the IF.

Silicone-sponge rubber-face seals take up the tolerance differences and provide the air seal.

TABLE MG.10  
DAVID LEDs

LED LABEL	LED SIGNIFICANCE
VCR ON 1,2,3	ON: VCRs powered ON OFF: VCRs powered OFF
CAMERA ON 1	ON: Camera powered ON OFF: Camera powered OFF
CAMERA ON 2	ON: Camera powered ON OFF: Camera powered OFF
CAMERA ON 3	ON: Camera powered ON OFF: Camera powered OFF
MIC	ON: Microphone enabled OFF: Microphone disabled
SCREEN	ON: Screen enabled
REC 1	ON: VCR 1 recording OFF: VCR 1 not recording
REC 2	ON: VCR 2 recording OFF: VCR 2 not recording
REC 3	ON: VCR 3 recording OFF: VCR 3 not recording

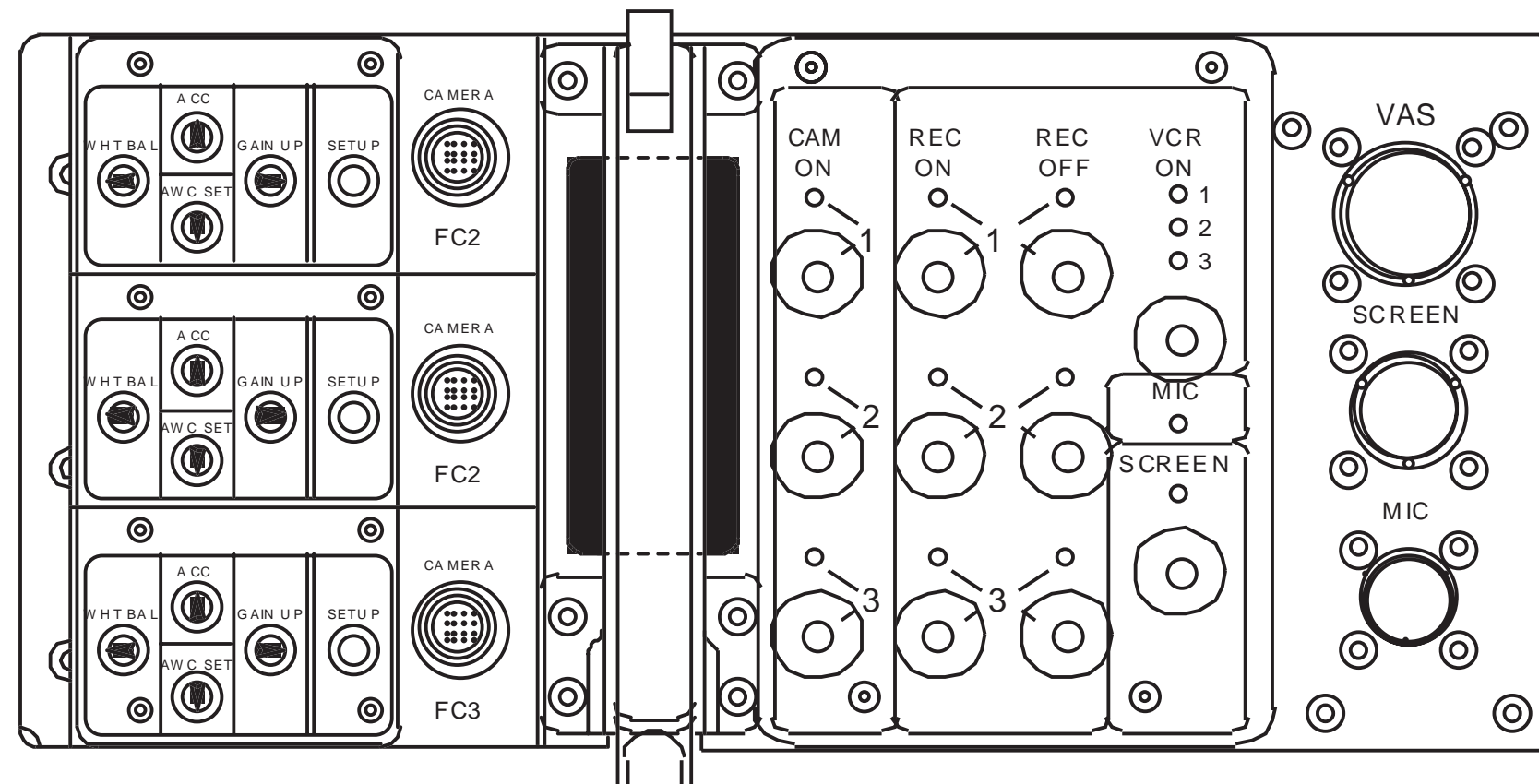

Figure MG-293 DAVID General Layout





Figure MG-294 Front Panel of DAVID

S97-06745

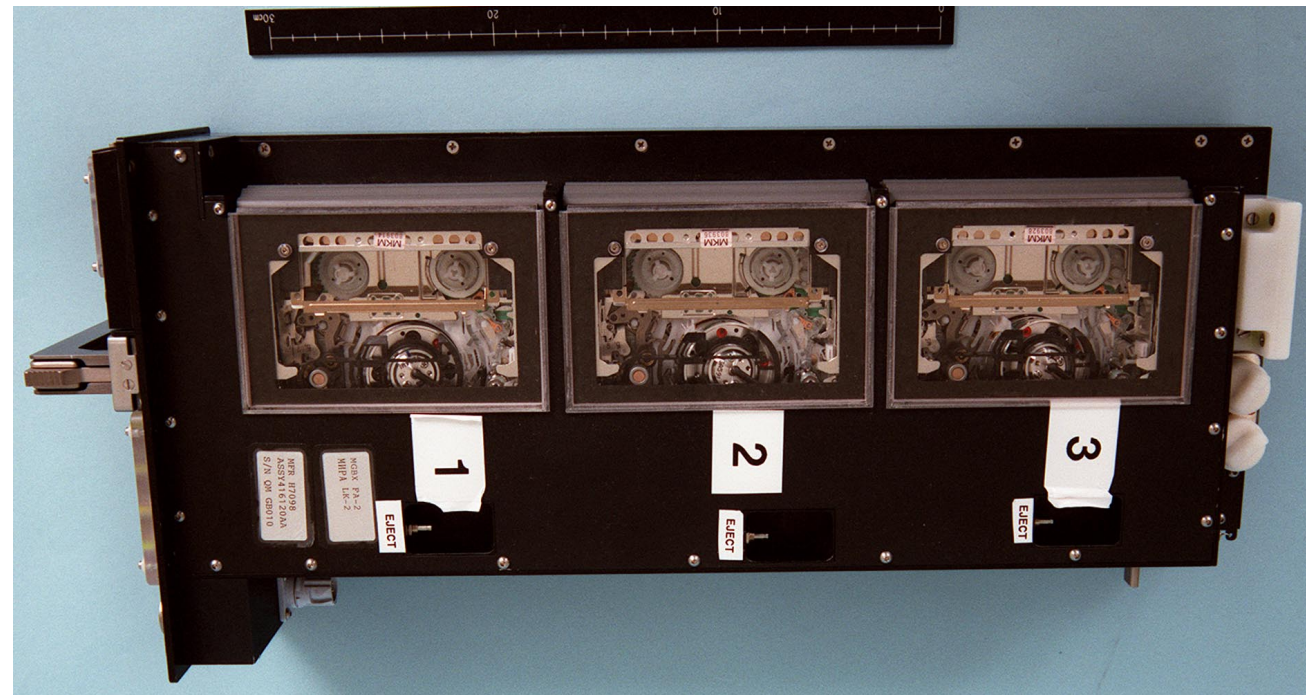

Figure MG-295 DAVID VCRs Top

S97-06746

TABLE MG.11  
DAVID FRONT PANEL SWITCHES (FLIGHT UNIT)

SWITCH LABEL	SWITCH TYPE	FUNCTION
VCR 1/2/3 POWER	Pushbutton	ON: Power to all 3 VCRs OFF: No power to VCR and Camera
VCR 1 RECORD	Pushbutton	ON: VCR 1 recording OFF: VCR 1 not recording
VCR 2 RECORD	Pushbutton	ON: VCR 2 recording OFF: VCR 2 not recording
VCR 3 RECORD	Pushbutton	ON: VCR 3 recording OFF: VCR 3 not recording
SCREEN	Pushbutton	ON: +8.4 V to video screen unit connector OFF: No power to video screen unit connector
CAMERA 1/2/3 WHITE BALANCE	Pushbutton	ATW: Auto tracing white balance control mode selected AWC: Auto white balancing control mode selected MANU: Manual white balancing control selected
CAMERA 1/2/3 AGC	Pushbutton	OFF: Automatic gain control disabled LOW: Video gain increases approximately +6 dB MID: Video gain increases approximately +9 dB HI: Video gain increases approximately +12 dB
CAMERA 1/2/3 AWC SET	Pushbutton	Enable auto white balance control mode
CAMERA 1/2/3 GAINUP	Pushbutton	OFF: Video amplifier gain set to the fixed value LOW: Video gain increases approximately +6 dB MID: Video gain increases approximately +9 dB HI: Video gain increases approximately +12 dB
CAMERA 1/2/3 SETUP	Pushbutton	Enter setup mode
CAMERA 1/2/3 ON	Pushbutton	ON: Camera active OFF: Camera inactive



## IF Front Panels

The IF has two front panels that provide controls and connector mounting. The lower panel, shown in Figures MG-296 has the ON/OFF circuit breakers for the facility, experiment power, and both IF fans. Switch guards are placed near the switch levers. Green Light-Emitting Diodes (LEDs), which indicate function status, are mounted under each function control circuit breaker. The panel provides the mounting for both of the 27V DC Payload Utility Panel B power feeds. All lower panel switches are dual labeled for both English and Russian.

The IF upper panel provides the opening for the DAVID. When installed, the DAVID front panel overlaps the IF upper panel slightly. Mounting for the Mir Interface to Payload Systems-2 connector is provided. The GB data and power connectors, the only electrical interface between the GB and IF, are located on a recessed panel. \*

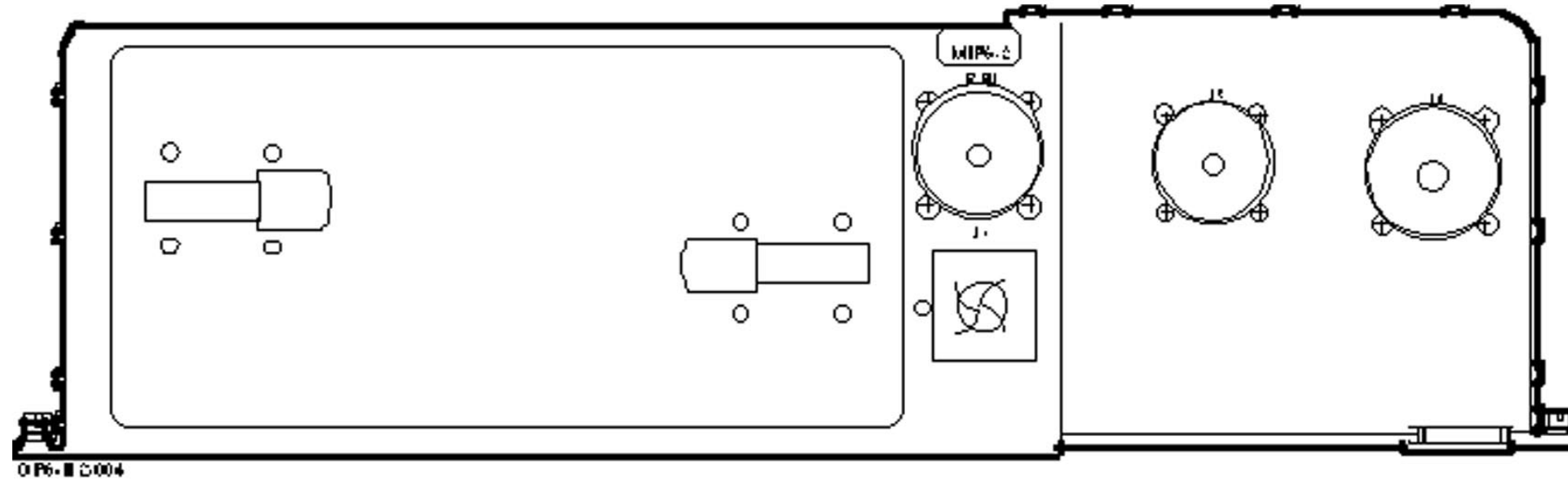

Figure MG-297 IF Upper Control Panel

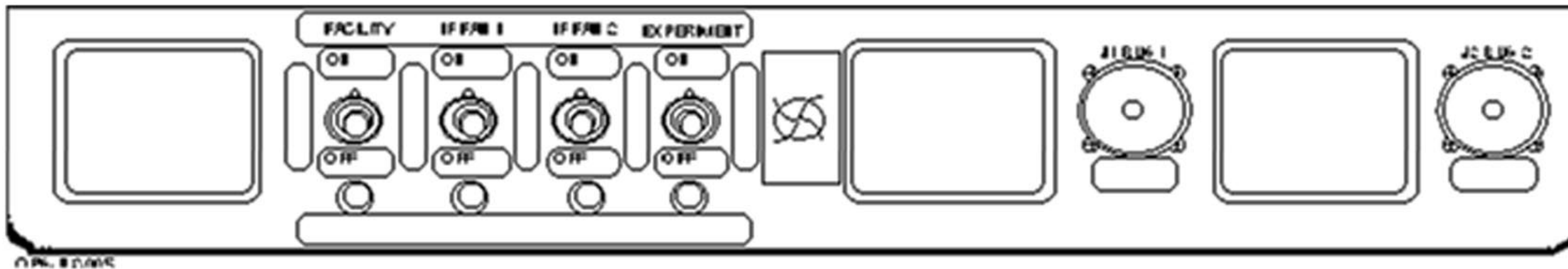

Figure MG-296 IF Lower Control Panel



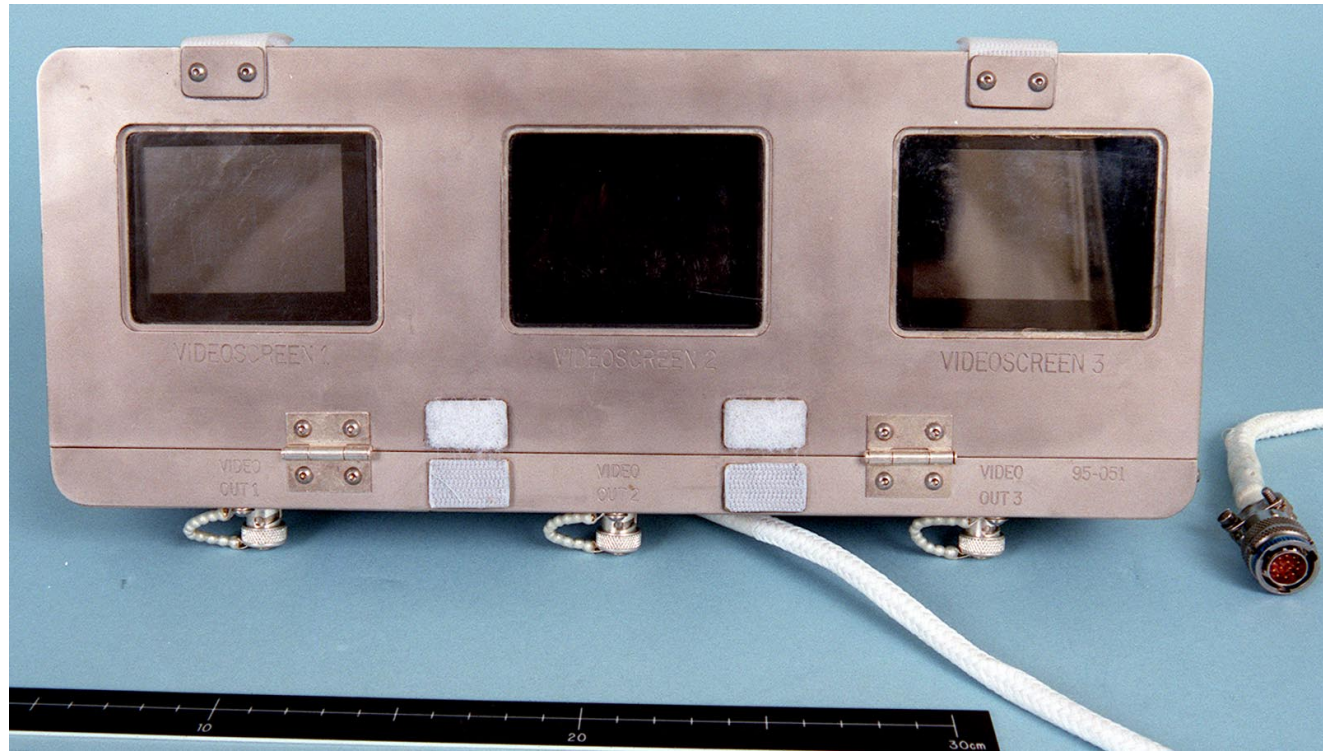

Figure MG-298 Video Box

S97-06717

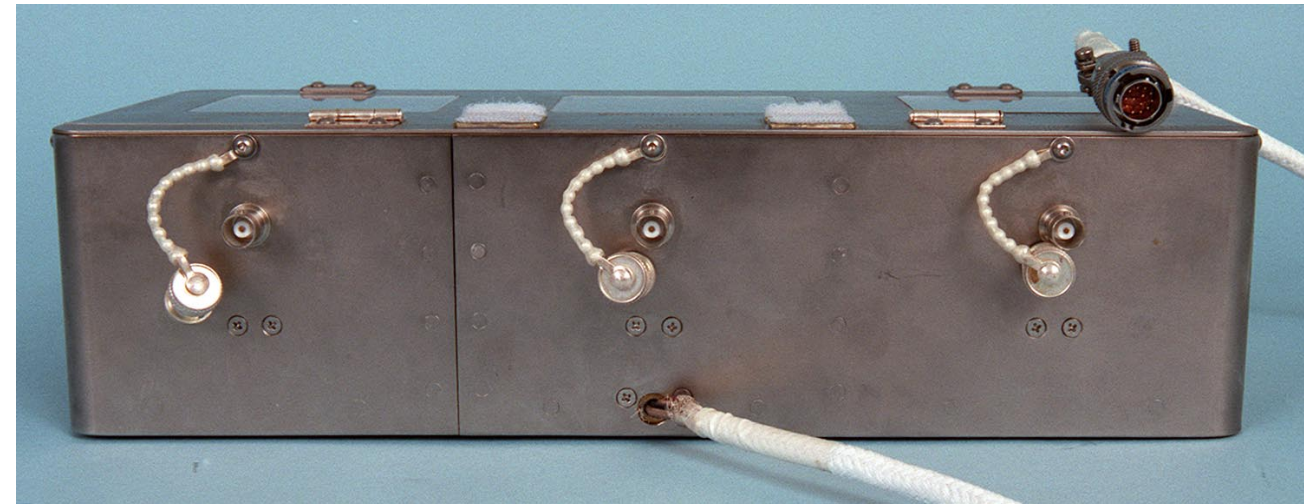

Figure MG-301 Video Box Cable Connectors

S97-06719



Figure MG-299 Video Box Opened

S97-06718



Figure MG-300 DAVID Cable

S97-06732

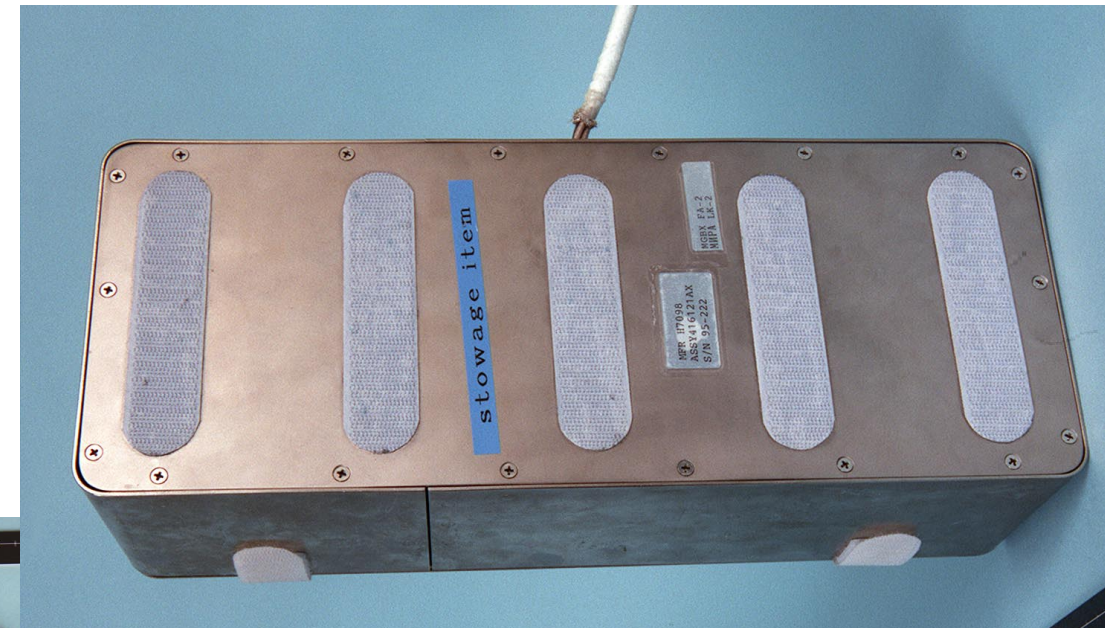

Figure MG-302 Back of Video Box

S97-06720





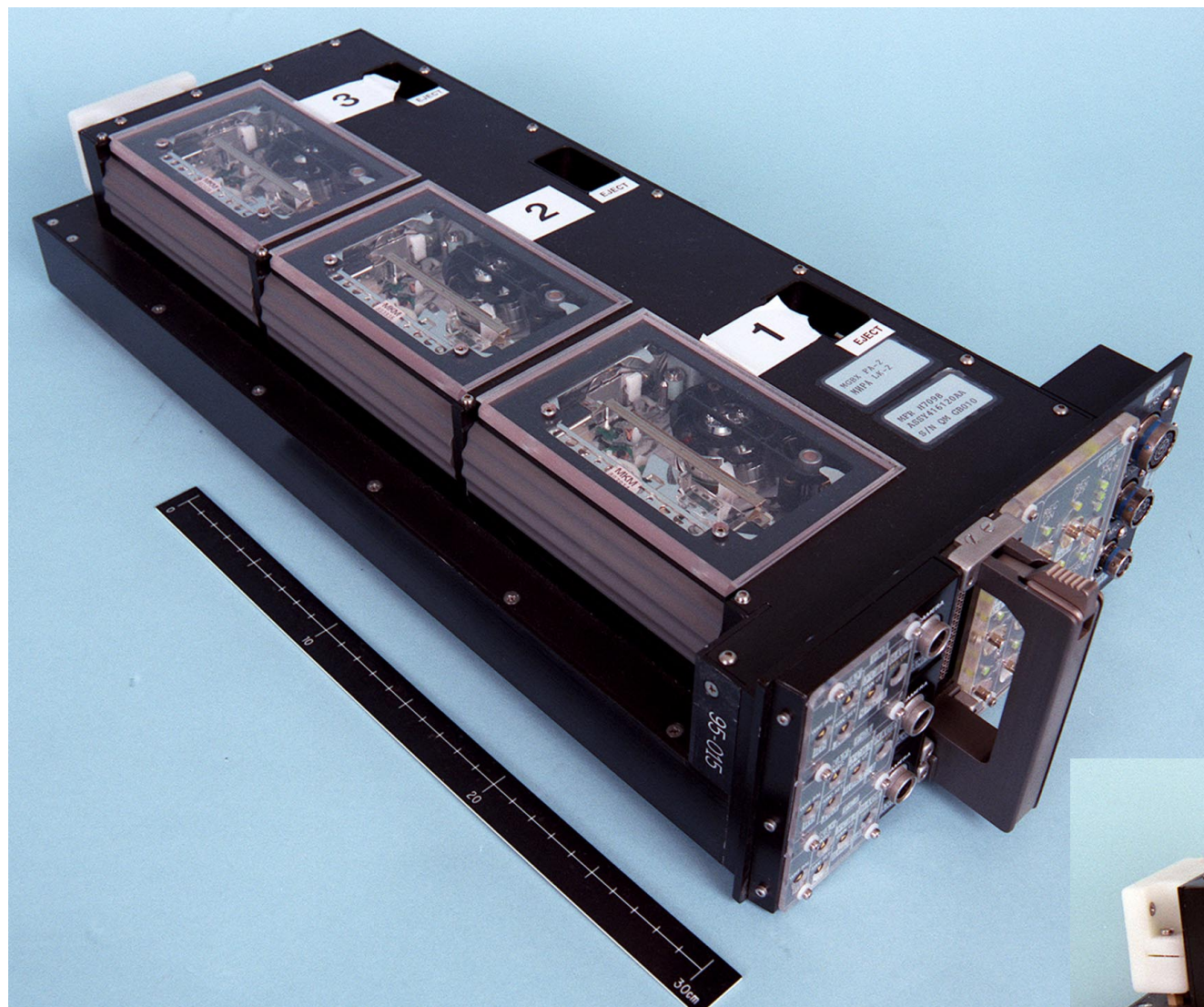

Figure MG-303 DAVID

S97-06739

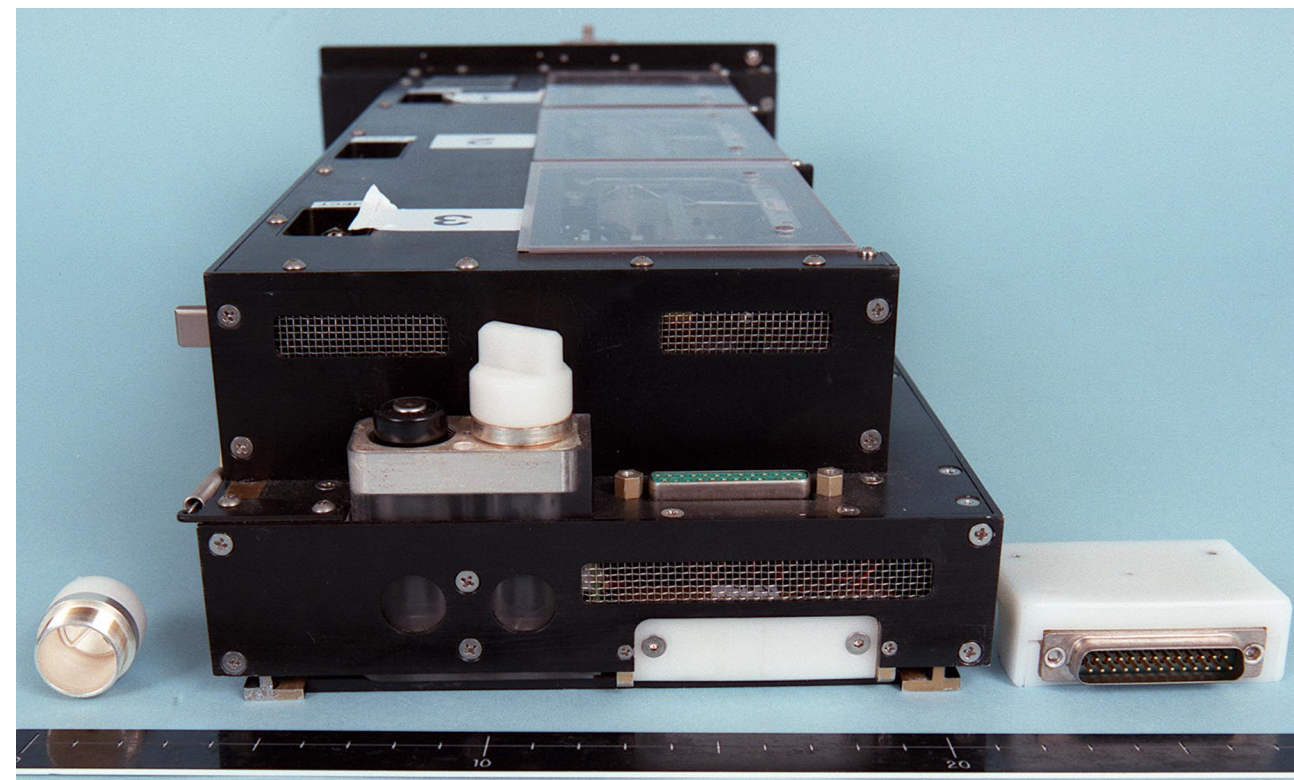

Figure MG-305 Rear View of DAVID

S97-06742

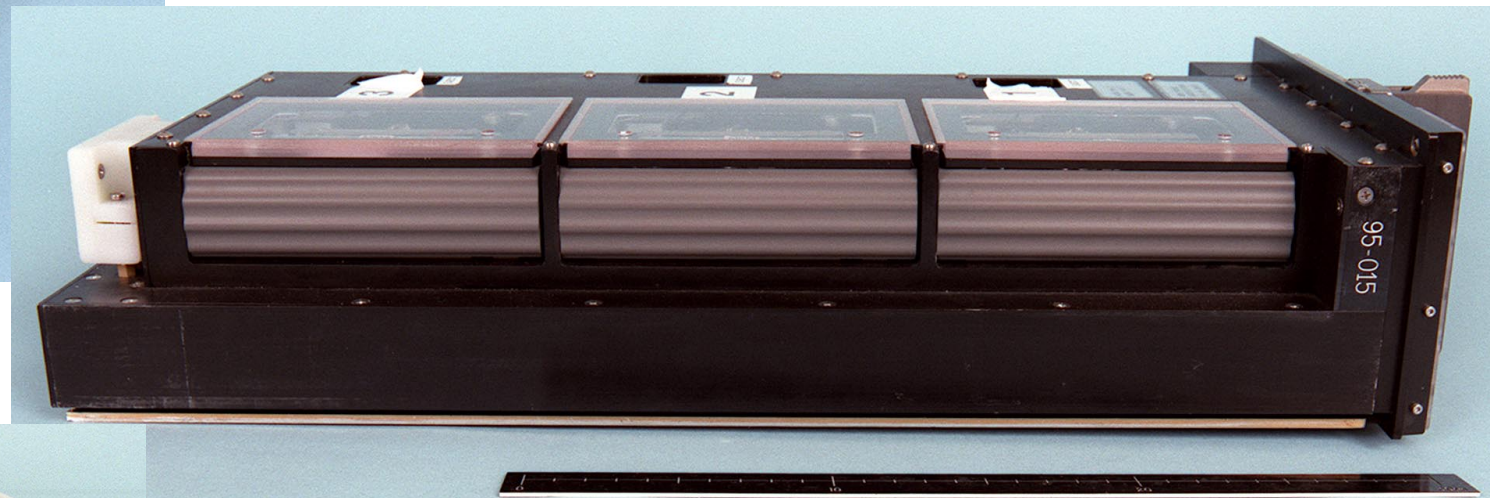

Figure MG-306 DAVID Tape Decks

S97-06740

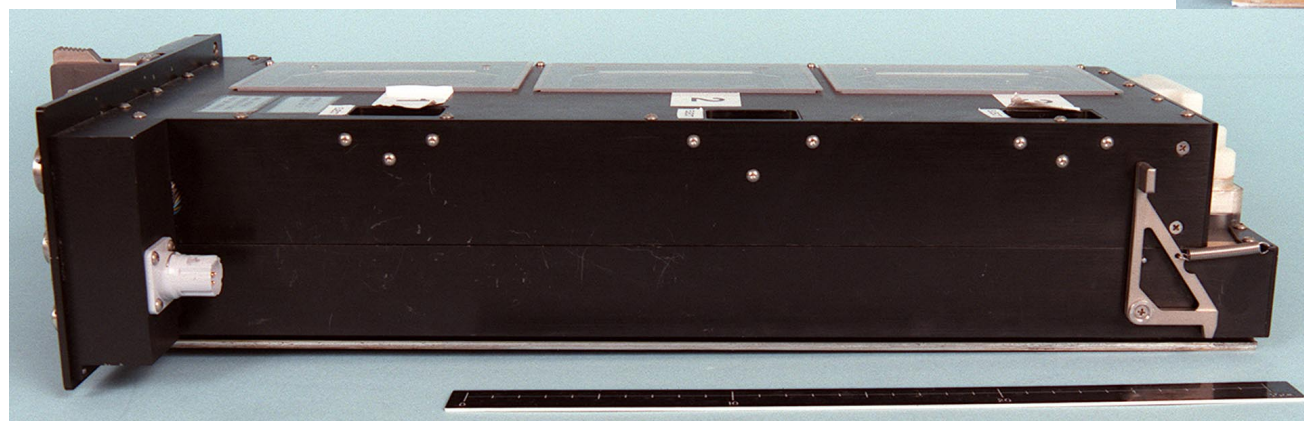
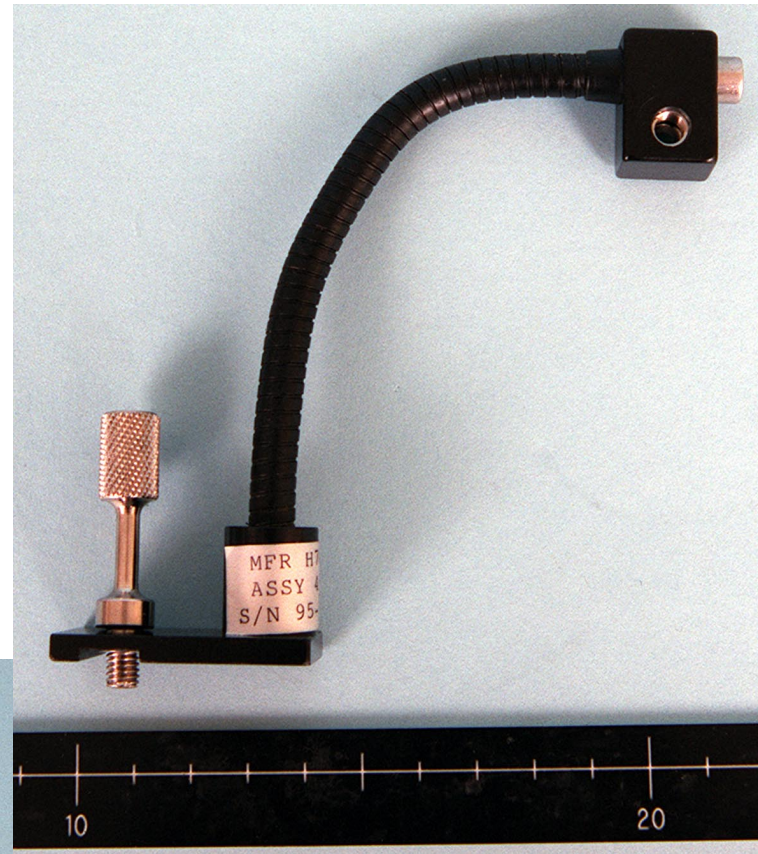

Figure MG-304 DAVID Right Side

S97-06743



Figure MG-307 MGBX Gooseneck Stand (Training)



S97-06747

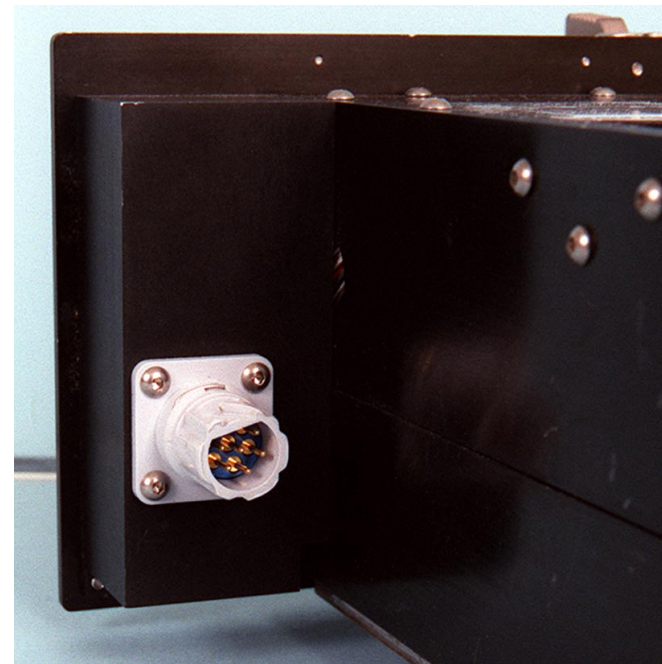

S97-06744

Figure MG-310 MGBX Cable Connector Behind Front Panel of DAVID



S97-06752

Figure MG-312 MGBX Spare Parts (Training)

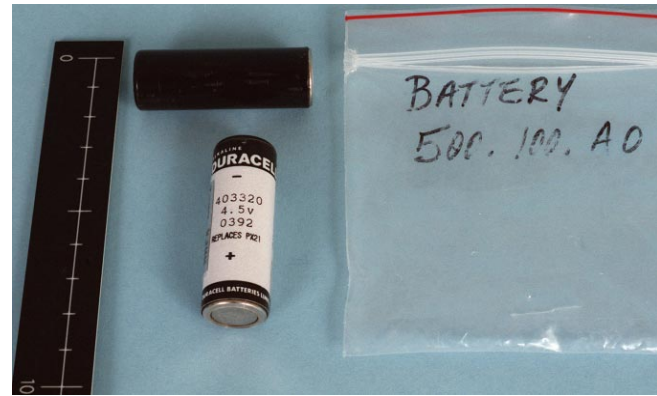

S97-06738

Figure MG-308 MGBX Batteries

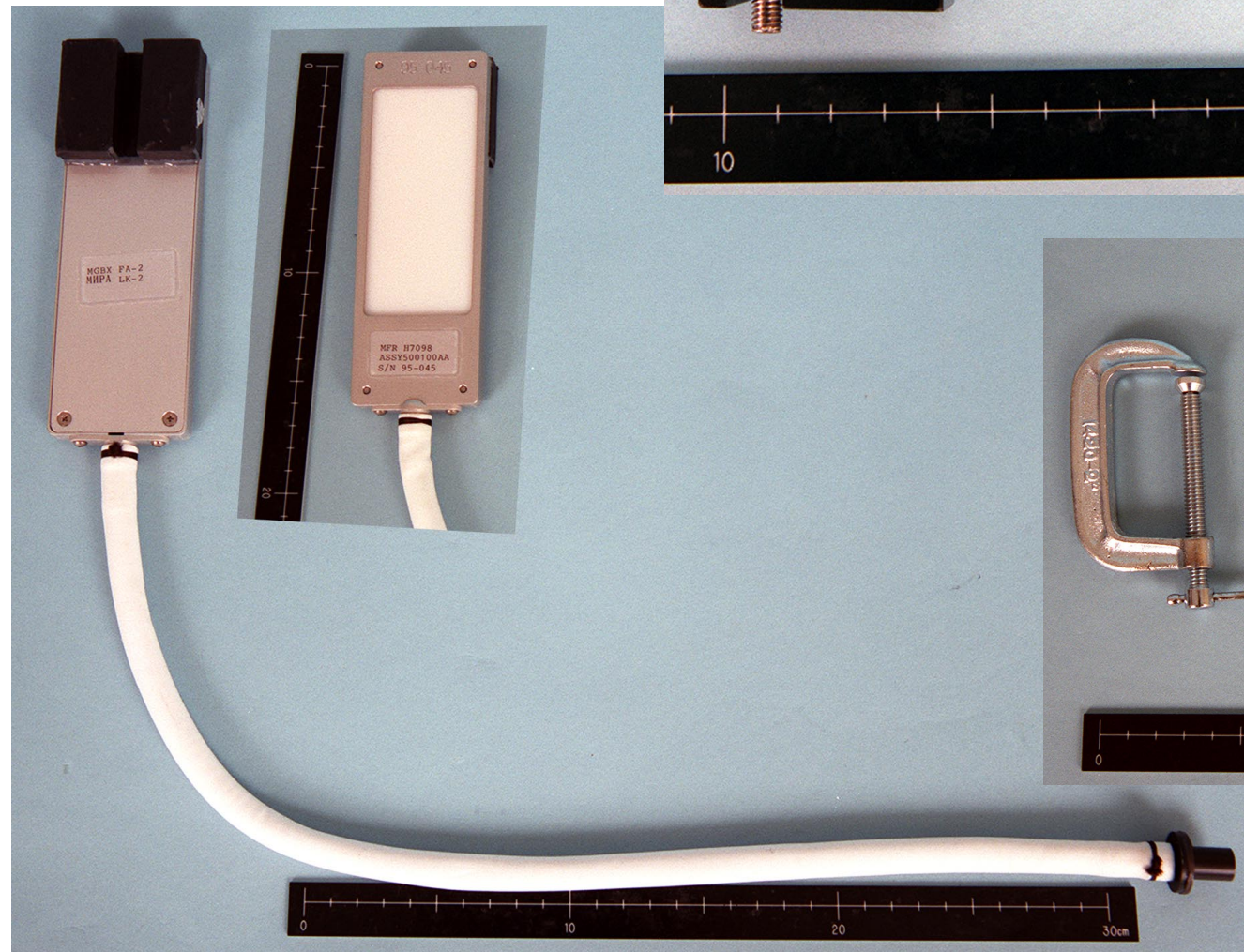

S97-06748

Figure MG-309 MGBX Light Panel (Training)

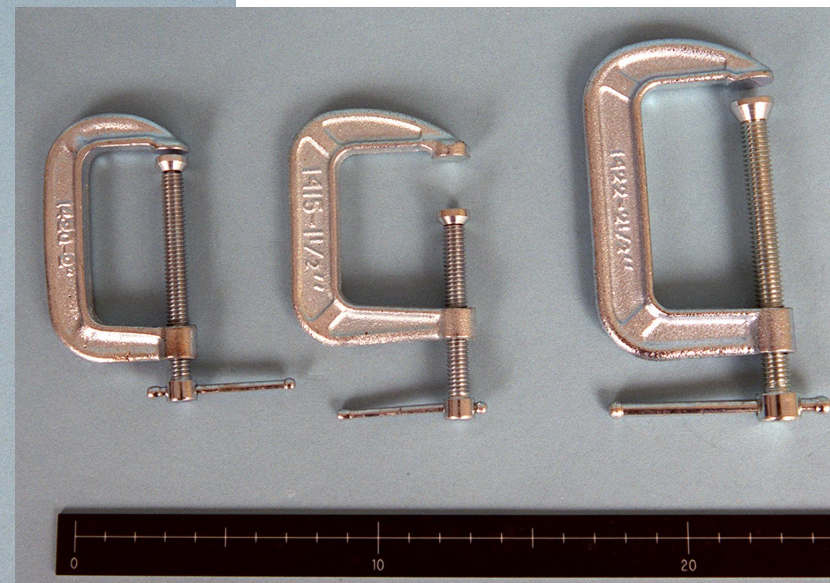

S97-06753

Figure MG-311 MGBX C-Clamps (Training)



S97-06751

Figure MG-313 Light Port Plugs (Training)





S97-06756

Figure MG-314 Glove Port Pocket Side



S97-06757

Figure MG-316 Glove Port Pocket Back



S97-06758

Figure MG-317 Glove Port Pocket Lid

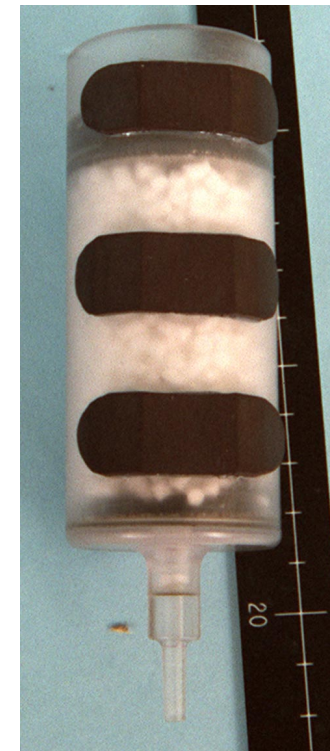

S97-06770

Figure MG-319 Filter Post

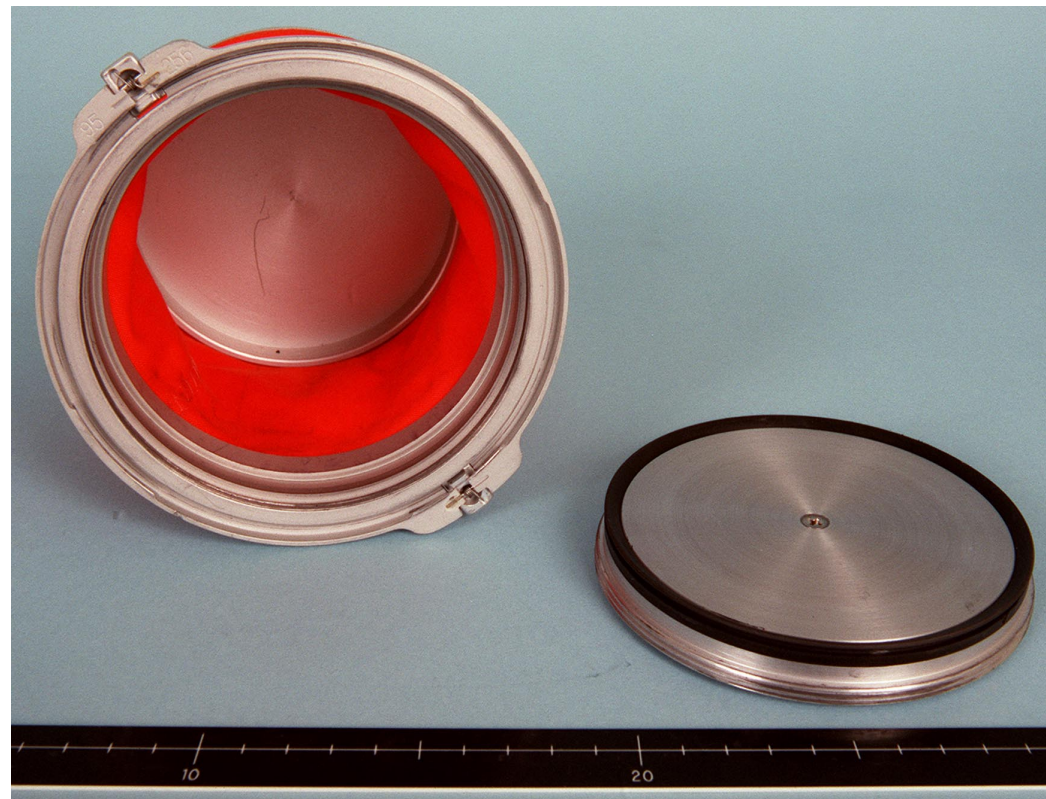

S97-06759

Figure MG-315 Interior of the Glove Port Pocket

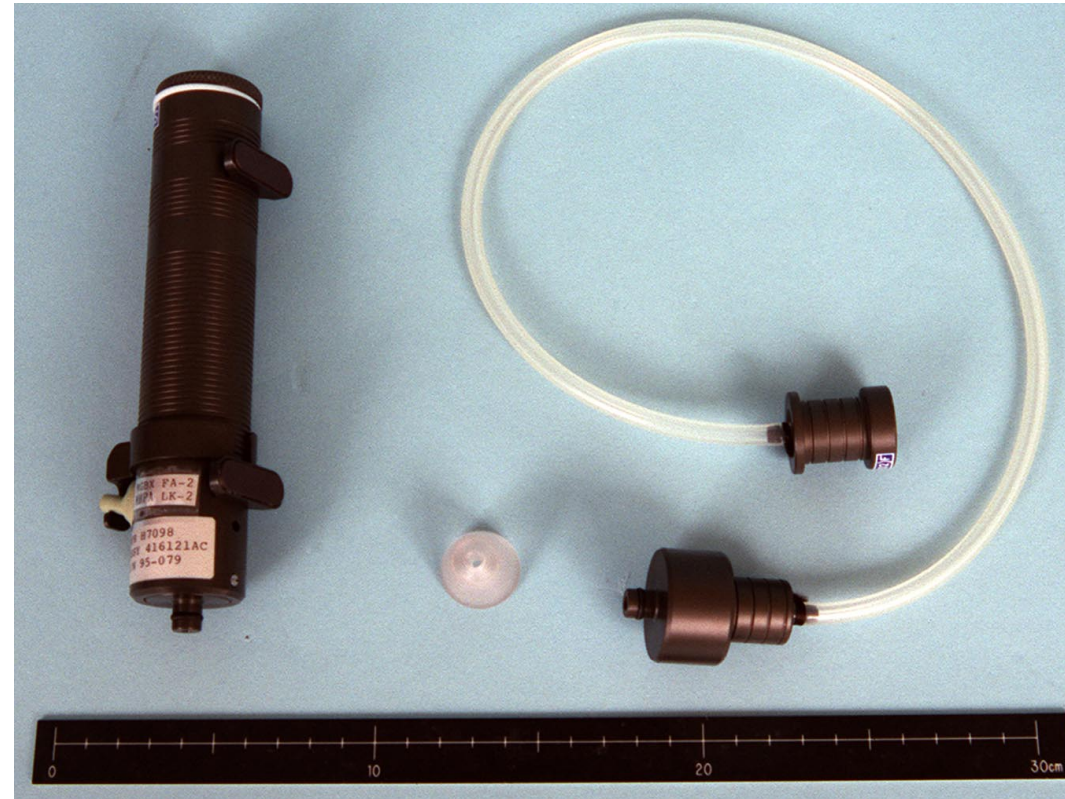

S97-06777

Figure MG-318 Scavenge Pump Assembly

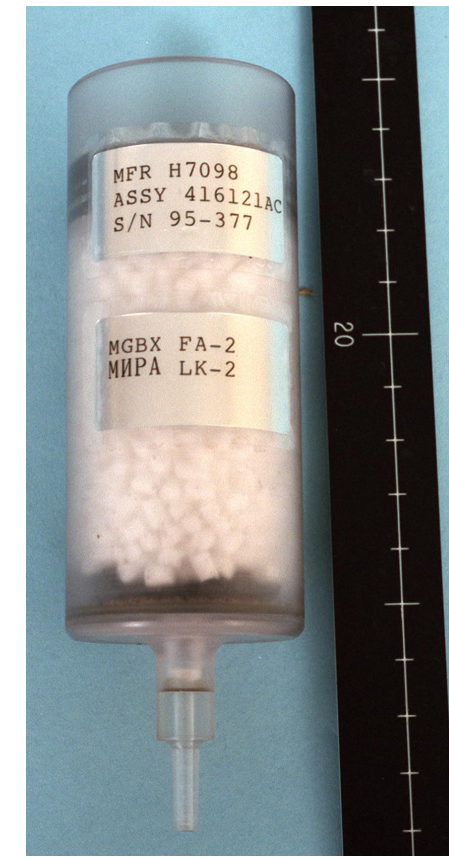

S97-06764

Figure MG-320 Filter Post Back



# MICROGRAVITY VIBRATION ISOLATION MOUNT (MIM)

## OPERATIONS OVERVIEW

This operation includes the sessions necessary to set up the MIM facility, prepare it for experiment operations, and deactivate it after experiment operations are complete.

The MIM is designed to isolate experiments from g-jitters in the frequency range 0.01 to 100 Hz, while transmitting quasi-static accelerations below 0.01 Hz to the experiment mounted on the MIM. The system is capable of isolating an experiment mass exceeding 100 kg and can attenuate spacecraft vibrations by up to 60 decibels, providing experiments with a clean vibration environment.

## HARDWARE DESCRIPTION

The MIM consists of three major components: a fixed stator, the free flotor, and a fixed Auxiliary Control Unit (ACU). The MIM achieves isolation in 6 degrees of freedom (DOF) using eight Lorenz actuators. These actuators consist of permanent magnets on the flotor interacting with voice coils mounted on the stator.

## MIM STATOR

The stator is a closed box structure 395 by 415 by 115 mm (15.56 by 16.34 by 4.54 in.) The stator is a closed box structure that acts as the base from which the flotor is supported. The top surface of the stator supports eight voice coils, which protrude up between magnets on the flotor external and internal walls so the coils intersect the magnetic field lines of the permanent magnets. The top surface of the stator supports three Position Sensor Devices (PSDs) onto which the laser diodes are

imaged for tracking the flotor position and orientation. The stator houses a triaxial accelerometer head used to monitor the accelerations of the stator. The stator incorporates two fans to provide forced air cooling for the stator electronics. The top surface of the stator includes mating attachment points for the latch mechanism on the flotor. The stator top surface also supports fixtures that limit the travel of the flotor to prevent contact between the flotor magnets and the stator coils.

## MIM FLOTOR

The MIM flotor consists of an inverted box-like structure with a free surface area of 362 by 362 mm (14.25 by 14.25 in.) and external and internal walls approximately 106 mm (4.16 in.) high. The internal and external walls are spaced so there is approximately 23 mm (0.9 in.) of rattle space for the flotor in each of three linear DOF.

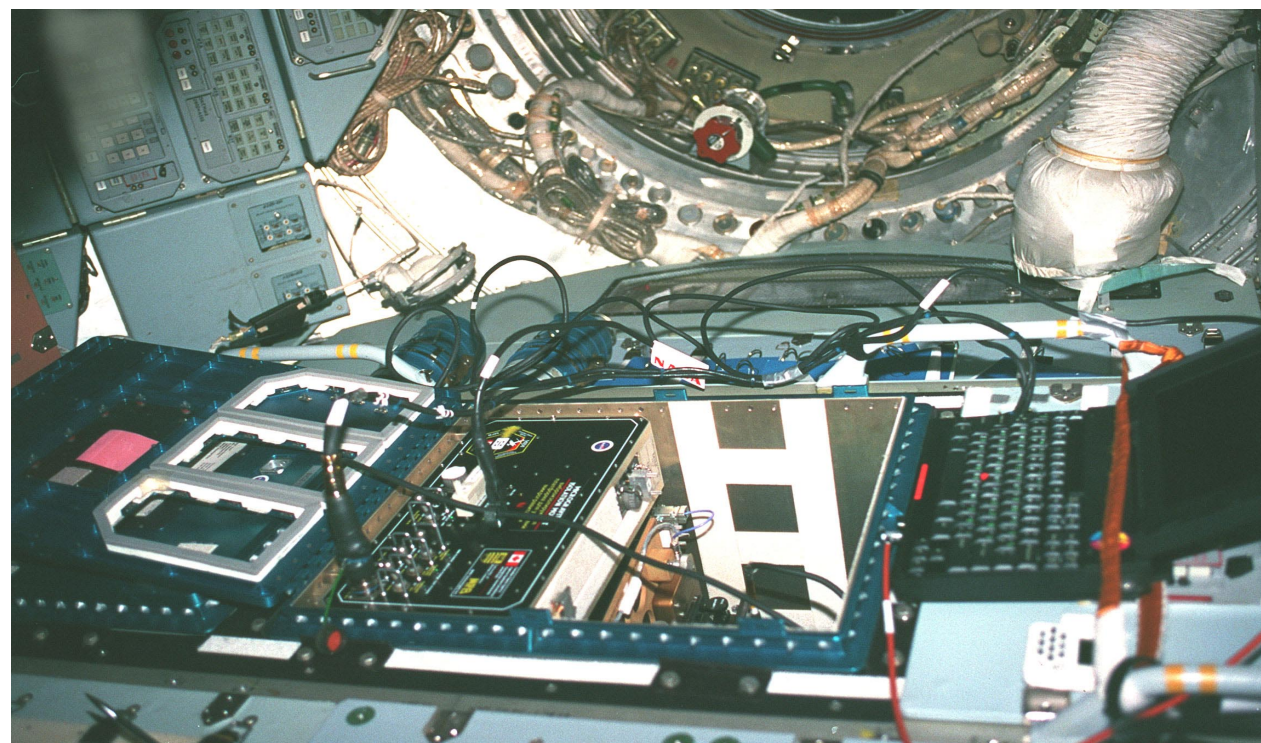

Figure MG-322 MIM with MIPS-2L in Priroda with Locker Door Open

NM21-384-017

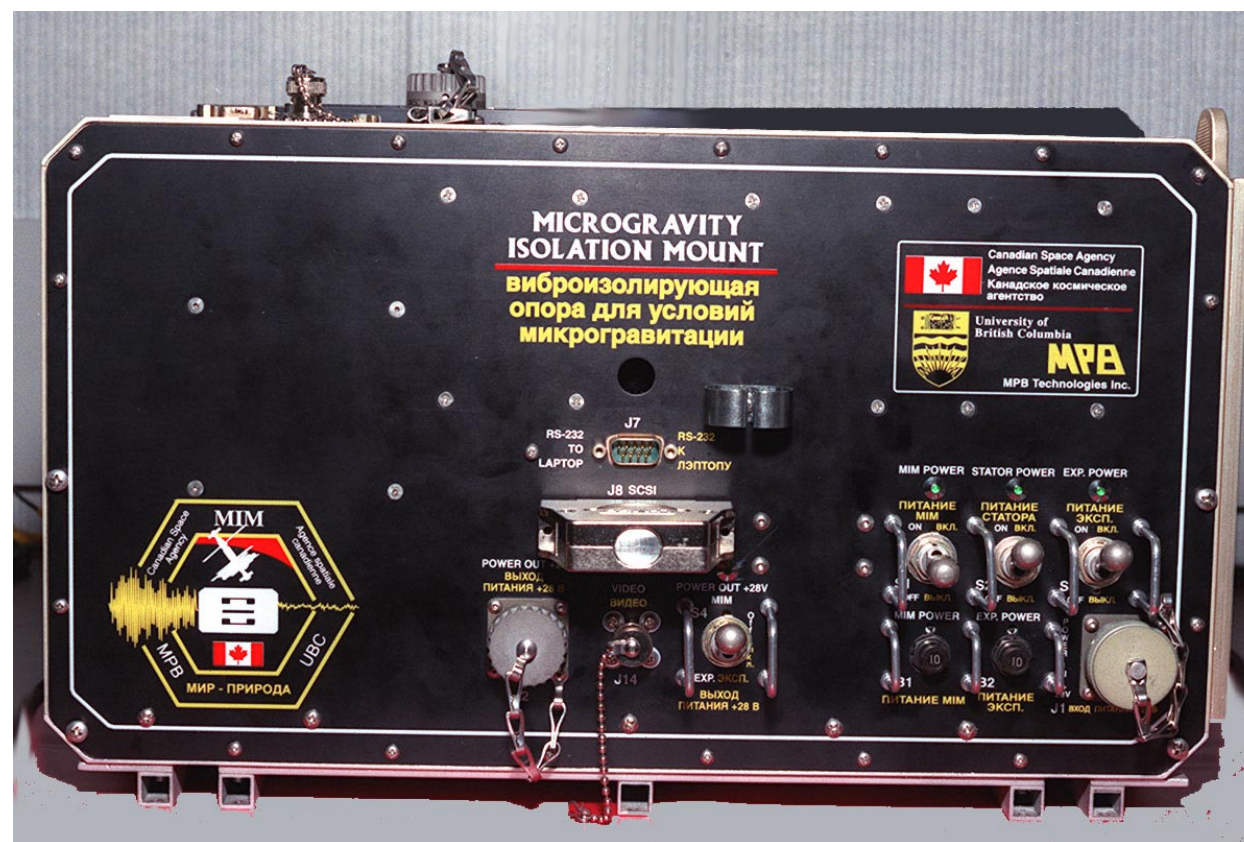

Figure MG-321 MIM

S95-11118

The upper surface of the flotor acts as a platform onto which g-sensitive experiments are mounted. The top surface of the flotor plate has mounting holes for supporting the g-sensitive experiments. A connector for passing power to the experiment is mounted on the flotor.

Connectors are used for passing as much as eight data signals from the experiment to the MIM signal conditioning and data acquisition subsystem. Four control lines are used for passing control signals from the MIM computers to the experiment. Two of the external walls of the flotor that support the flotor side of a latch mechanism are used to secure the flotor to the stator during launch and during non-operational times on orbit.

## MIM ACU

The ACU houses the Digital Signal Processor, a MIM 486 Computer, and a Digital Interface Board used to communicate with the electronics

D.I.D.

MIM Double Locker  
Installation

**Principal Investigator:**  
Bjarni Trygvasson  
CSA  
(514)926-4731

Lawrence Vezina  
(514)926-4768

## MIM DATA CABLE

P/N: SKM46111505-303  
Qty: 1  
Mass: .74  
Power: N/A  
x,y,z: 220 cm (lgth)  
Loc: Priroda, SIC2-I-1A

## MICROGRAVITY ISOLATION MOUNT UNIT (MIM)

P/N: 451P-0A003  
Qty: 1  
Mass: 30.84 kg  
Power: 357 W  
x,y,z: 51.61 x 44.02 x 25.32 cm  
Loc: Priroda, SIC2-II-1  
DID#: SLM46111806



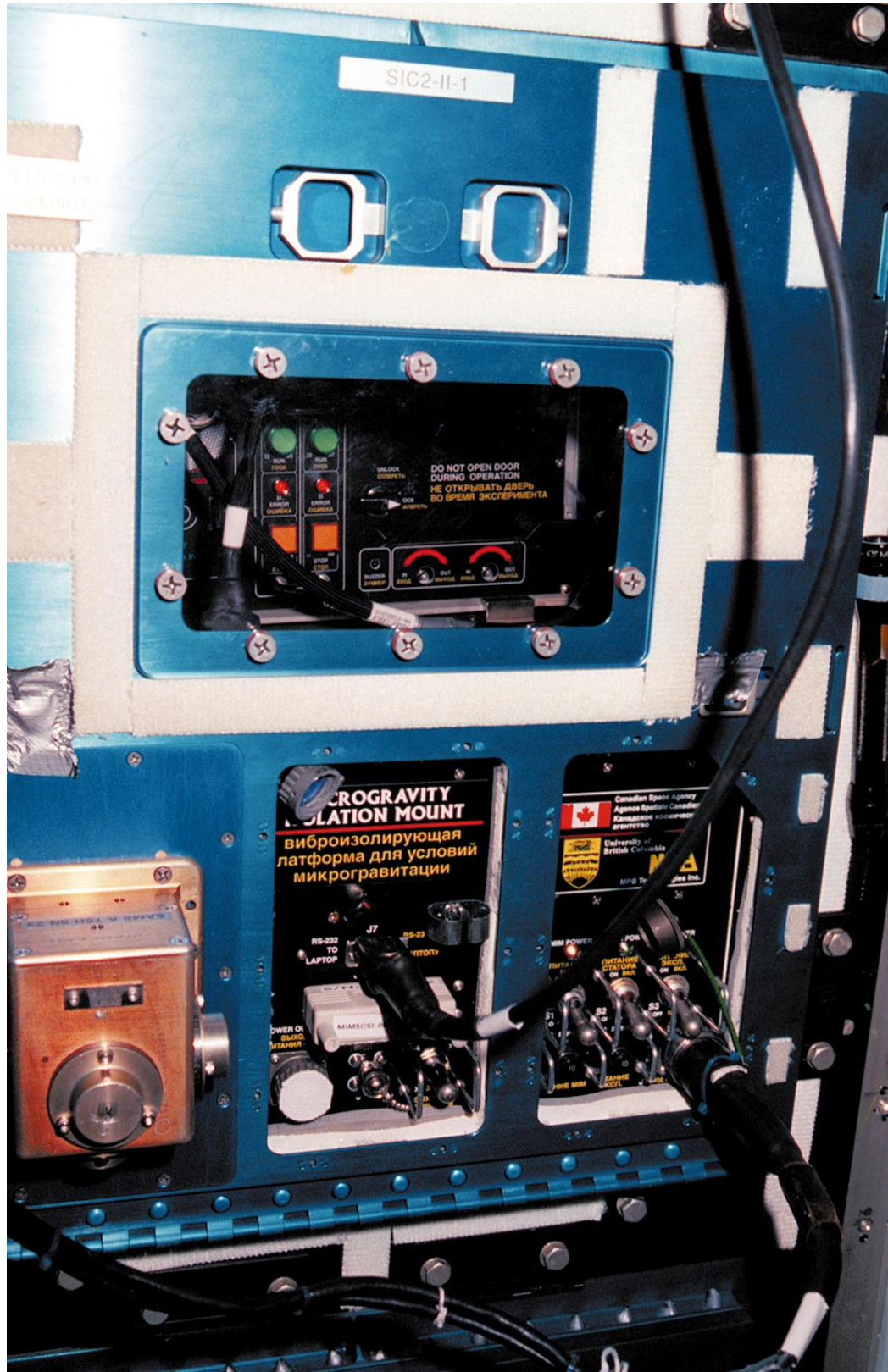

NM23-018-26

Figure MG-323 QUELD in MIM

### MIPS-2L LAPTOP COMPUTER (SEE OPS)

The MIM user interface, via the MIPS-2L, which is an International Business Machines (IBM) ThinkPad 750C Laptop Computer, is detailed in USA-MIPS-2L/94-108. The MIPS-2L is used to implement a MIM-specific Graphical User Interface (GUI) to facilitate crew interaction with the MIM and the experiment mounted on the MIM.



NM21-386-011

Figure MG-324 MIM and MIPS-2L in Priroda with Locker Door Closed





Figure MG-325 Filter Assemblies, Stator

S96-00149

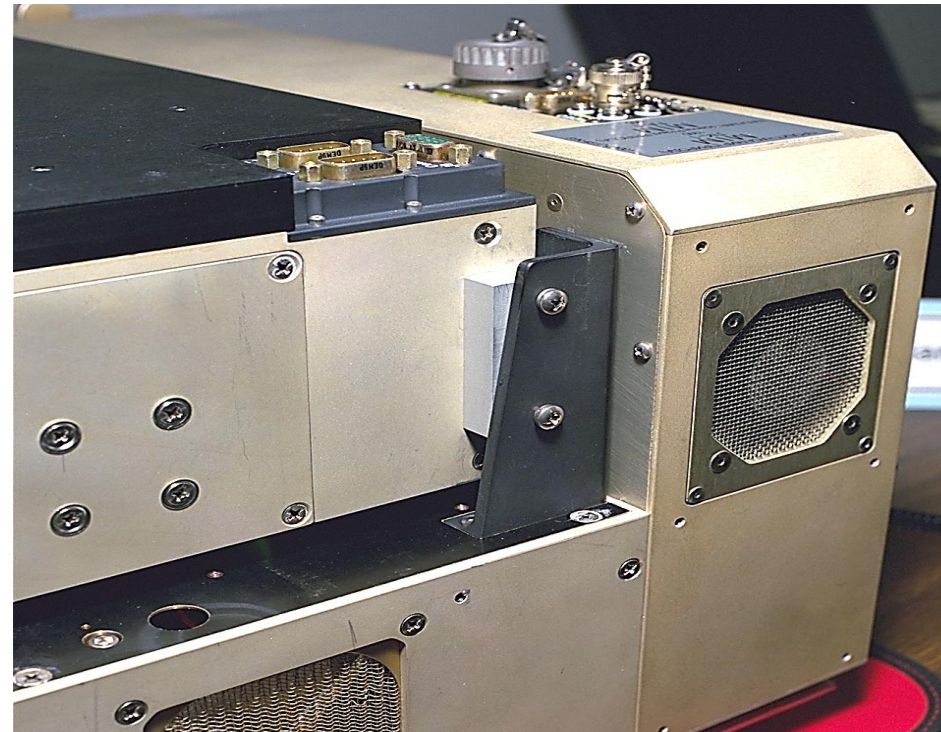

Figure MG-327 MIM Assembly with Flotor

S95-11109

housed in the stator. The front panel of the ACU supports the following power connectors:

- Power switches
- Indicator
- Lights
- Circuit breakers
- RS-232 connector for the MIPS-2L
- Small Computer System Interface connector for the MIPS-2C Magneto-Optical Drive (MOD)
- One video output connector

These connectors and switches are accessed through cutouts included in the double locker door.

The top surface of the ACU, within the double locker enclosure, supports a second RS-232 connector, a power output connector, and one video input connector.

The ACU houses a 1.2 Glovebox (GB) Hard Disk Drive (HDD), which protrudes out of the ACU back wall into the corner of the stator housing. The ACU is bolted to the front wall of the stator unit.



Figure MG-326 MIM Filter Assembly, ACU

S96-00151

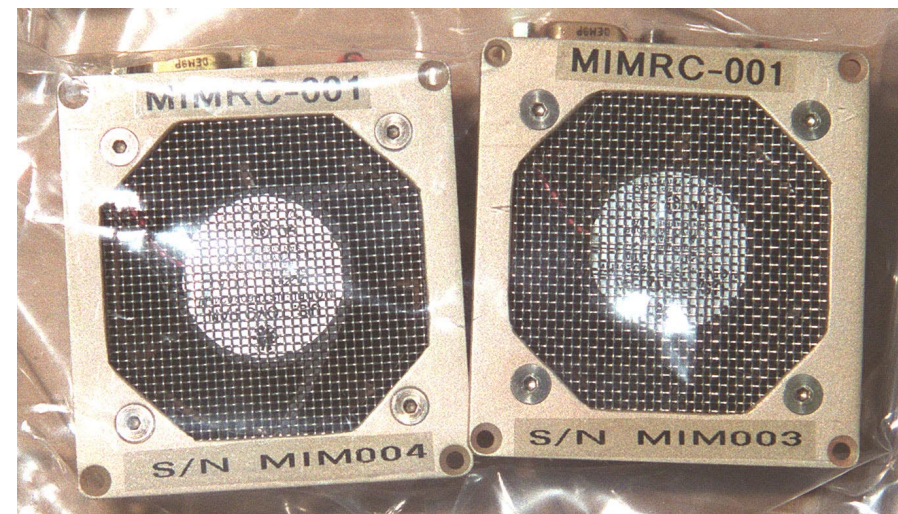

Figure MG-328 MIM Replacement Fans, ACU

S96-00146

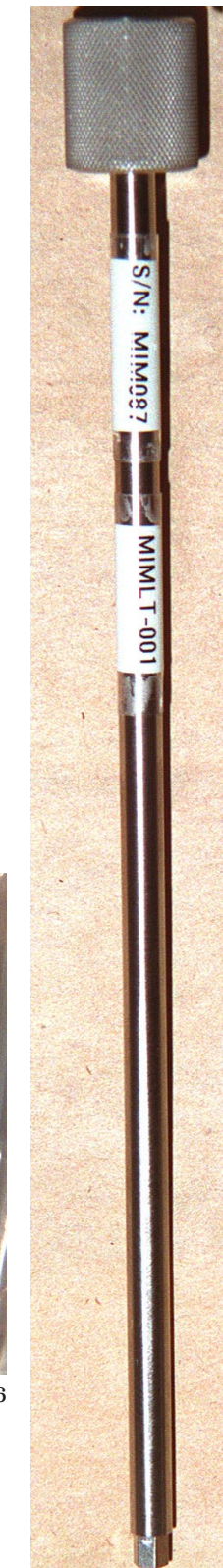

Figure MG-329 MIM Latch Tool

**MIM LATCH TOOL**

P/N: MIMLT-001  
 Qty: 1  
 Mass: 0.05 kg  
 Power: N/A  
 x,y,z: 27.94 x 0.64 cm  
 Loc: Priroda, SIC2-II-1

**REPLACEMENT FAN, ACU**

P/N: MIMRC-001  
 Qty: 2  
 Mass: 0.45 kg  
 Power: N/A  
 x,y,z: 4.13 x 7.30 x 8.89 cm  
 Loc: Priroda, SIC2-II-1

**FILTER ASSEMBLY, ACU**

P/N: MIMFL-001  
 Qty: 2  
 Mass: 0.45 kg  
 Power: N/A  
 x,y,z: 21.59 x 9.53 x 0.64 cm  
 Loc: Priroda, SIC2-II-1

**FILTER ASSEMBLY, STATOR**

P/N: MIMFL-002  
 Qty: 4  
 Mass: 0.45 kg  
 Power: N/A  
 x,y,z: 20.32 x 13.97 x 0.64 cm  
 Loc: Priroda, SIC2-II-1

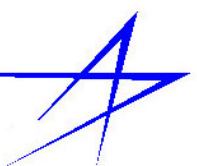

## HARDWARE INTERFACE WITH SYSTEMS

### MIM POWER DISTRIBUTION

The power switches are all locking type switches with switch guards and circuit breakers that are resettable. The indicator lights on the front panel are illuminated only when the particular power switch is turned on. The switch functions, Light-Emitting Diode (LED) indications, and circuit breaker protection are shown in Tables MG.12 through MG.15.

The external power output connector on the ACU front panel is available to power hardware external to MIM and the double locker. The power output connector on top of the ACU is available to power auxiliary experiment hardware inside the closed locker. Switch S-4 on the ACU front panel selects the source of power for these two ACU power outlets. All power connectors on the ACU have protective caps secured to the ACU by cables.

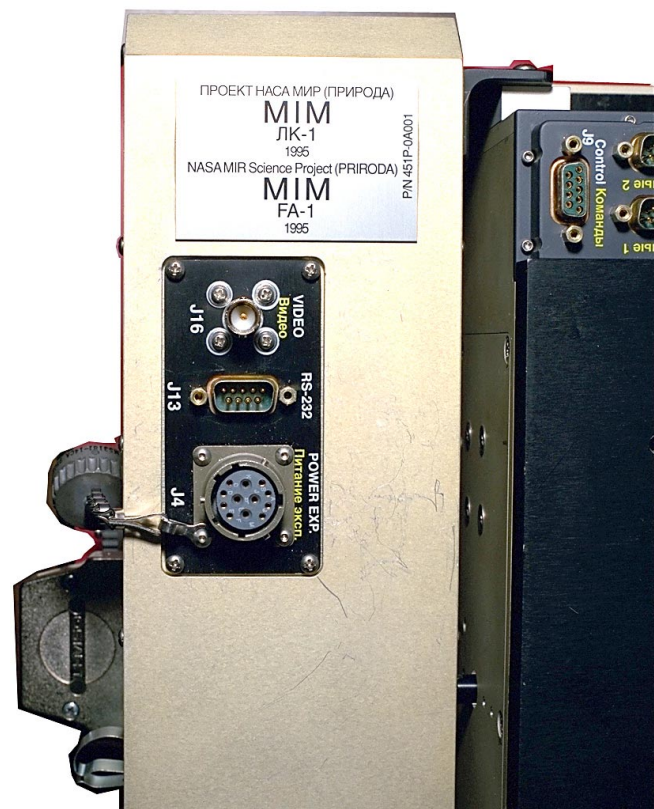

S95-11111

Figure MG-330 MIM Power Distribution Connectors

### VIDEO CONNECTORS

The video connectors on the top surface of the ACU and the front panel of the ACU feedthrough connections used to pass video signal from an experiment out through the locker door for display and or recording using the GB recorder.

### MIM ELECTRONICS SYSTEMS

A block diagram of the MIM electronics is shown in Figure MG-331.

TABLE MG.12  
LIST OF CIRCUIT BREAKERS, ACU FRONT PANEL

BREAKER LABEL	ID	FUNCTION
MIM POWER	B 1	Used to reset power to the MIM
EXPERIMENT POWER	B 2	Used to reset power to the experiment

TABLE MG.13  
LIST OF SWITCHES, ACU FRONT PANEL

SWITCH LABEL	ID	FUNCTION
MIM POWER	S	ON: MIM Main Power ON OFF: MIM Main Power OFF
STATOR POWER	S	ON: MIM Main Power ON (power to Stator) OFF: MIM Main Power OFF (power to ACU only)
EXPERIMENT POWER	S	ON: Power to POWER OUT J3 connector OFF: Experiment Power OFF
POWER OUT +28 V MIM EXPERIMENT	S	MIM: Power to POWER OUT J2 and J4 connectors from Experiment side power source EXPERIMENT: Power to POWER OUT J2 and OFF: No power to POWER OUT J2 and J4 connectors

TABLE MG.14  
LIST OF LED, ACU FRONT PANEL

LED LABEL	FUNCTION
MIM POWER	ON: Power to the MIM OFF: No power to the MIM
STATOR POWER	ON: Power to the Auxiliary Unit OFF: No power to the Auxiliary Unit
EXPERIMENT POWER	ON: Power to the POWER OUT J3 connector OFF: No power to the POWER OUT J3 connector
POWER OUT +28 V	ON: Power to the POWER OUT J2 and J4 connectors OFF: No power to the POWER OUT J2 and J4 connectors

TABLE MG.15  
LIST OF CONNECTORS, ACU FRONT AND TOP PANEL, FLOTOR

LOCATION	CONNECTOR LABEL	ID	FUNCTION
AUX.UNIT Front Panel	MIM POWER IN 28 V	J1	MIM Main Power Supply Connector
AUX.UNIT Front Panel	POWER OUT MIM EXPERIMENT	J2	Provide power to experiment hardware outside double locker.
AUX.UNIT Front Panel	SCSI	J8	Connect MIPS-2 MOD to MIM.
AUX.UNIT Front Panel	RS232 to laptop	J7	Connect MIPS-2L to MIM.
AUX.UNIT Front Panel	Video	J1 4	Connector used to connect to a video system.
AUX.UNIT Top Panel	RS232	J1 3	RS-232 line used to communicate with the experiment on the flotor.
AUX.UNIT Top Panel	VIDEO	J1 6	Connector used to connect to a video system.
AUX.UNIT Top Panel	POWER EXPERIMENT	J4	Connector used to provide power to experiment hardware located on the top panel of the auxiliary unit or Velcro to the inside walls of the double locker.

## MIM INTERFACE TO EXTERNAL UNITS

The MIM interface to the following external hardware:

- MIM to MIPS-2L Laptop Computer:

The MIM user interface is through the MIPS-2L, which is an IBM ThinkPad 750C Laptop Computer. The MIPS-2L is used to implement a MIM-specific GUI to facilitate crew interaction with the MIM and the experiment mounted on the MIM.

During normal operations, the MIPS-2L is connected to the MIM. The MIM can operate in a preset mode without the MIPS-2L being connected or powered on. However, without the MIPS-2L on, there are no indications of the status of MIM operations.

- MIM to MIPS MOD:

The MIM utilizes the MIPS-2C MOD to transfer MIM and MIM experiment data to optical drives for storage, transport down to the ground via the Space Shuttle, and transfer of data to the MIPS-2 system for downlink.

- MIM to Microgravity Glovebox (MGBx):

The MIM utilizes the MGBx video recorder for recording of MIM experiment video signals.

- MIM Interface to the Double Locker:

The MIM interface to double locker consists of dagger pins mounted on the aft lower surface of the stator, which fit into mating holes on the back wall of the double locker, and two fixtures on the bottom of the stator immediately behind the ACU-stator interface. These fixtures are fastened to the supporting plate in the base of the double locker with screw fasteners.

## MIM SOFTWARE OVERVIEW

The MIM includes two computers. The Power Control Panel (PCP) housed in the ACU controls the data acquisition functions, executes control algorithms, then sends control signals to stator

DACs to control the MIM actuators and four experiment control lines. A block diagram of the MIM data flow is show in Figure MG-88. The PCP transmits all raw data from the data acquisition electronics to the Systems Control Panel (SCP) for further processing and data archiving. The SCP receives data from the PCP, passes the data through digital filters, decimates data, and transfers the data to HDD. The SCP acts as the interface between the user operating the MIPS-2L laptop and the MIM.

- MIM Data Archiving and HDD Organization:

The MIM acquires data from the MIM control sensors and from the experiment mounted on the flotor. This data is stored on the HDD in directories set up for the specific

experiment. Because the HDD does not have sufficient storage capacity to store all data acquired during a complete flight increment, data must be copied periodically to optical disks using the MIPS-2 MOD.

- MIM Data Flow:

All data acquired by MIM is transferred to optical disks.

- MIM Data Analysis Flow:

Experiments results and MIM operational parameters are sent via downlink to the ground during a flight increment. This activity is done using the MIPS-2 downlink

capability. Because the amount of data typically acquired by MIM is prohibitive for downlink, only results of analysis performed on the data on orbit are downlinked.

- MIM GUI Displays:

Interaction with the MIM is primarily through the MIPS-2L Laptop computer. To facilitate this, a GUI is run on the MIPS-2L. \*

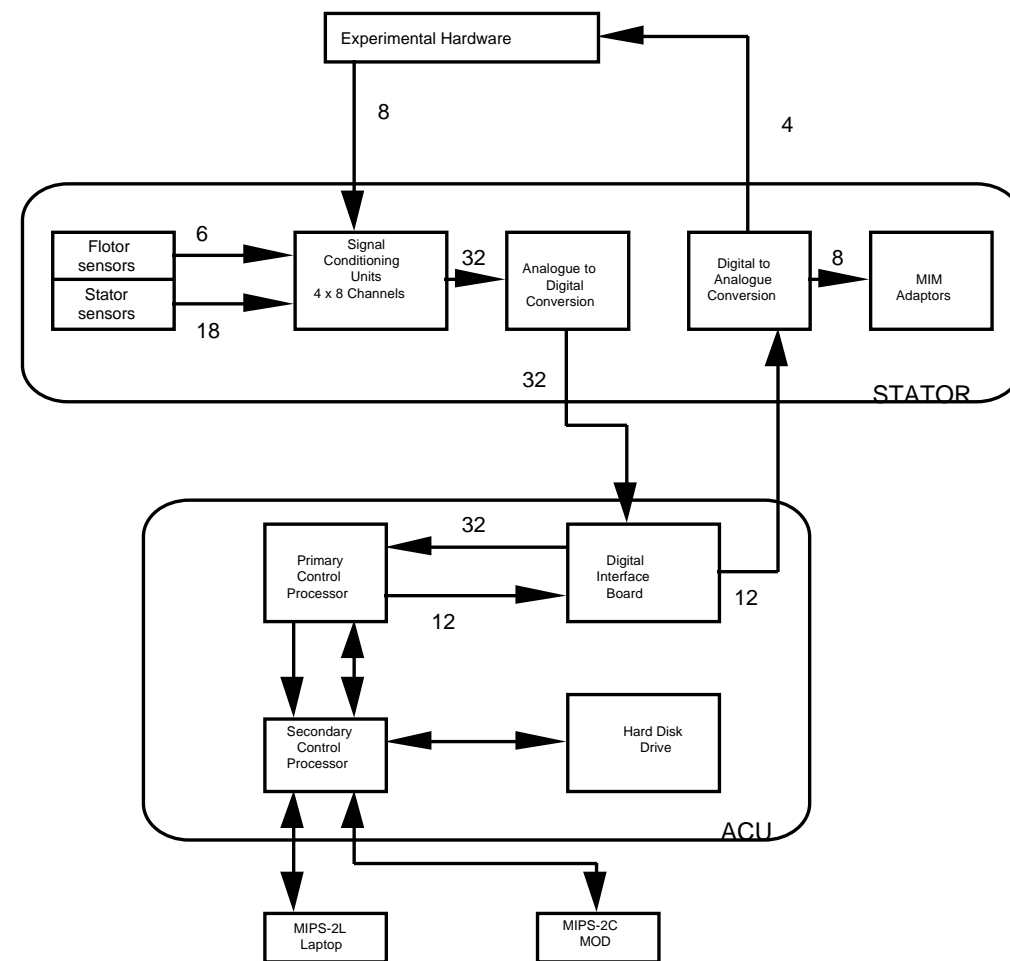

Figure MG-331 MIM Electronics Block Diagram

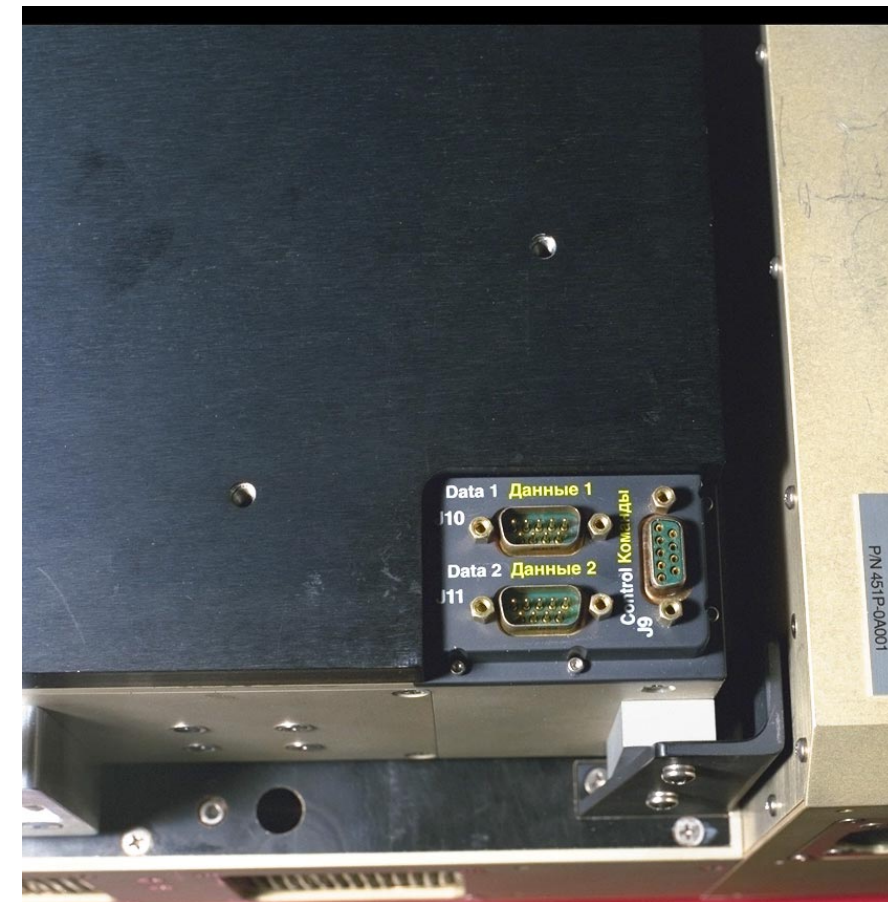

Figure MG-332 MIM Data Connectors

S95-11111





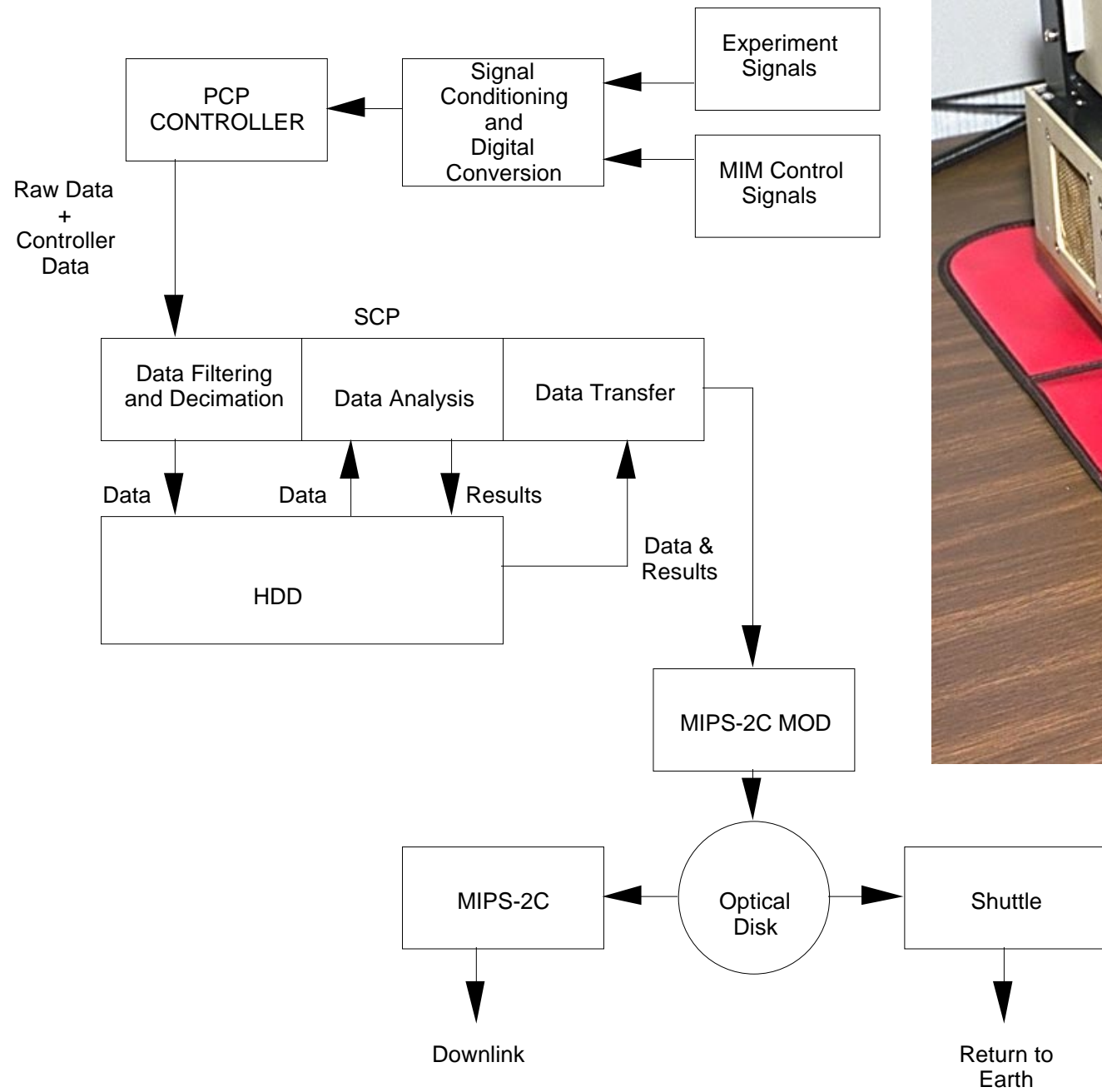

Figure MG-333 Block Diagram of MIM Data Flow



Figure MG-334 MIM Unit

S95-11092

# OPPOSED FLAME FLOW SPREAD ON CYLINDRICAL SURFACES - MGBX

## EXPERIMENT DESCRIPTION

The approach to the operation of the experiment is to ignite cellulose samples under various airflow velocities and seek a flammability limit based on flow velocity. Then, fuel samples will be ignited at ambient temperature and under various flow velocities to characterize the flame-growth and flame-spread rates. Temperatures of the fuel, the flame itself, and the combustion products will be measured for comparison with the theory.

## SCIENCE OBJECTIVES

This document provides general technical and hardware design data for the Opposed Flow Flame Spread On Cylindrical Surfaces (OFFS) planned for integration and flight aboard the Priroda Module of the Russian Mir Station. The purpose of this document is to give a top level review of the hardware that is required for flight and that will meet the requirements of the USA-MG-MGBX-OFFS/96-100.

## FUNCTIONAL OBJECTIVES

- Install experiment apparatus into the MGBx.
- Eight experiment runs are required for this investigation.
- Samples of cellulose cylinders of various thicknesses are mounted in cartridges for ignition and observation of the subsequent combustion.
- Samples of the resulting products of combustion are taken for later analysis.
- Video images are recorded of the composition processes, the displays, and the flow velocity indicator.

- Velocities of the air flowing into the combustion region are measured and recorded, and 35 mm still photograph sequences are taken of the spreading flames.

## HARDWARE DESCRIPTIONS

The OFFS is comprised of three major components: two OFFS Modules and an OFFS Parts Box. The OFFS Parts Box contains a control box, 8 fuel sample assemblies, 8 exit screens, 8 sample removal tools, 4 oxygen sensors.

## TECHNICAL DESCRIPTION

The purpose of the OFFS is to extend the understanding of the interplay of the radiative processes that affect the mechanism(s) by which flames spread, or fail to spread, over solid fuel surfaces in the presence of an opposing oxidizer

flow. The flow velocities of interest in these tests (2 to 10 cm/sec) cannot be observed in normal gravity because of buoyant (gravity-induced) convection. Ground-based experimental results have indicated that flammability and flame-spread rates can be greater than in normal gravity when materials are exposed to these low-speed flows in microgravity. This experiment will provide observations of flow and fuel temperature effects for comparison with normal gravity results and with theory.

## MECHANICAL DESIGN

The combustion parts box which was approved for STS-76, was utilized by the OFFS experiment. See USA-MG-MGBX-CFM/95-101 for details concerning the combustion parts box. The OFFS module is where the fuel samples were burned. The control box controlled all OFFS module

functions from outside the MGBX. The replaceable exit screens captured any particulates generated during burning.

## ELECTRICAL DESIGN

The OFFS electrical components are composed of the OFFS control box, the OFFS module, and the OFFS sample assemblies. All cabling is integral to the specific hardware components.

## OFFS MODULE ELECTRICAL

The MGBX supplies power to the OFFS module through a breakout box supplied by the MGBX. This breakout box will convert 28V DC to +5 V and  $\pm 12$  V needed for experiment operation. The OFFS module receives control from the control box via cable 3 that connects to the MGBX front door electrical feedthrough connector (MS3119E14-18). The OFFS module includes a

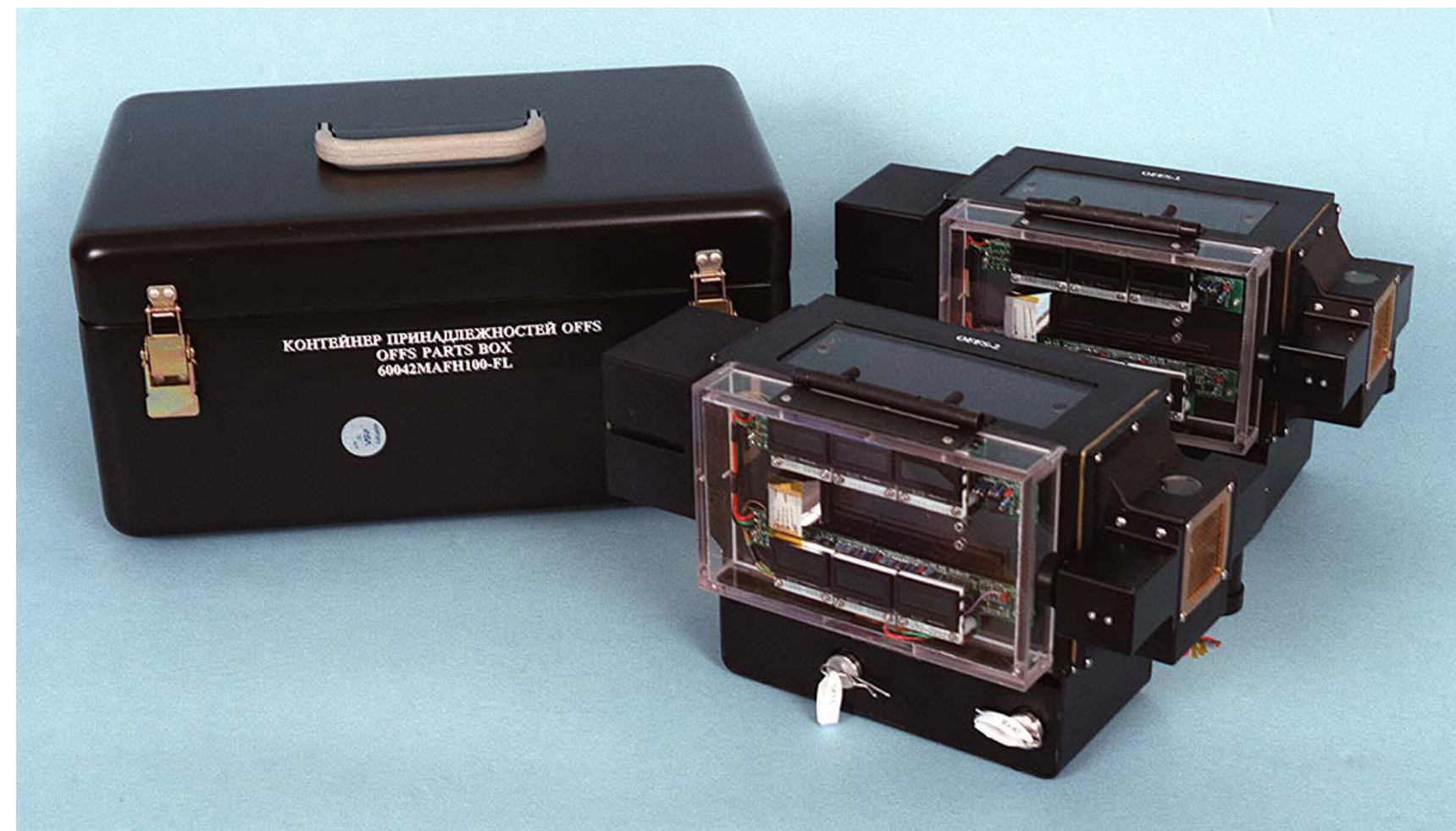

Figure MG-335 OFFS Flight Hardware

96-12673

D.I.D.

OFFS

**Principal Investigator:**  
R.A. Altenkirch

## OFFS MODULE

P/N: 60042MAFH000-FL2  
Mass: 4.54 kg  
Power: 37 W  
x, y, z: 33.02 x 15.11 x 19 cm

## OFFS PARTS BOX

P/N: 60042MAFH100  
Mass: 6.13 kg  
Power: N/A  
x, y, z: 33.02 x 29.59 x 20.80 cm



fan for airflow through the module. The OFFS module contains two switches located on the back that controls internal lighting. One switch activates the lights inside the ducts. This is used for viewing of sample burning patterns. The second switch allows the lights to be on continuously or strobing. Strobing of the lights is used for alternating detection of a burn pattern and flame shape in the recorded video. The OFFS module also contains two solenoids for the withdrawal of oxygen samples during preset time in the experiment run. The OFFS uses 14 Watts nominal power with a maximum power draw of 37 Watts.

### OFFS MODULE

The OFFS modules are identical metallic flow ducts. Air is pulled through the duct using a fan. An inlet section is where velocity measurements are made and an outlet section is where the fan is located. The test section is separated from the inlet and outlet sections by small mesh screens that condition the air flow and prevent the escape of any particulates created during the burning. The front wall of the test module is a window that can be opened to provide access for installing and removing the fuel sample assemblies. A fixed window is located in the top wall of the duct. Two gas sample bottles are located in each module. These gas sample bottles are evacuated miniature bottles that are opened before a sample run. The air sample taken was analyzed for oxygen concentration and content. All operations of the modules are controlled using the control box, located on the outside of the MGBX and connected through a connector in the MGBX front door.

### OFFS PARTS BOX

The OFFS Parts box contains the control box, the wire exit screens, fuel samples, and sample removal tools.

### Control Box

The control box operates all the functions for the OFFS module except lighting from outside the MGBX. The control box connects to the MGBX front door electrical feedthrough. The control box contains four switches and one knob. Table MG.16 lists the switches and the functions located in the control box.

Cable 1 connects power from the MGBX power conversion box to the OFFS module. Cable 2

connects the OFFS module to the electrical feedthrough located within the MGBX front door. The control box will then use cable 3 to connect to the electrical feedthrough connector (MS 3119E14-18) in the MGBX. The crew will interface with the OFFS test module to perform experiments. The control box, for all operations of the test module, is located outside the MGBX work area. Cooling of the OFFS is provided by forced convection of MGBX air and conduction and radiation. The OFFS module uses magnets to attach to the MGBX working area.

### Fuel Sample Assemblies

The Fuel Sample Assembly is a replaceable unit that is installed into the OFFS module. It consists of the combustion material supported on a metallic sheet, and instrumented with thermocouples. The fuel samples are cellulose (paper) cylinders of various thicknesses that are mounted to the metallic sheet. Electrical leads for all electrical functions are laid along the metallic sheet, collected at one corner forming a short cable. The cable is terminated in a connector plug that is inserted into a receptacle in the OFFS module floor.

### Fuel Sample Assembly Types

Three sample types will be used during the OFFS experiment and all the samples will have heater core units but the heaters will not be used to heat the samples.

Type (1) samples will be 7 mm in diameter at one end of the sample there will be a ceramic core 3 mm in diameter, leaving a fuel thickness of 2mm. The first section will be 20 mm long. The second section will be solid cellulose, 12.2 mm in diameter, also 20 mm long. Three samples of this type are required.

Type (2) samples will be 12.2 mm in diameter. At one end of the sample there was a ceramic core 8 mm in diameter, leaving a fuel thickness of 2 mm. The first section was 20 mm long. The second section was solid cellulose, 12.2 mm in diameter, also 20 mm long. Three samples of this type are required.

Type (3) samples was 12.2 mm in diameter. Ceramic cores were installed at each end for mechanical support, but burning was only to be observed over the solid section. Two samples of this type are required.

Cables 1 and 2 are integrated into the OFFS Module. Cable 3 is integrated into the Control box. Cables are insulated with teflon. The wire bundle is shielded with braided copper wire, and then covered with shrink tubing.

### Exit Screens

Eight exit screens are provided to be replaced inside the Module after each sample run. The screens prevent soot and contaminants from leaving the module.

### Removal Tools

The removal tool is a small bent aluminum lever used to pull the Fuel sample connector out of the plug in the Module floor. This tool is used upon exchanging the fuel samples after each run.

### OFFS INTERFACES

The OFFS has the following interfaces:

- MGBX power conversion box
- MGBX working area
- MGBX front door

### MASS PROPERTIES

Mass properties and dimensions are listed in USA-MG-MGBX-OFFS/96-100 Table 5.16.1. \*

TABLE MG.16  
CONTROL BOX SWITCH FUNCTIONS

SWITCH	FUNCTION	OPERATION	TYPE
Switch 1	Fan Power	Fan on Fan off	Toggle
Switch 2	Gas Sample #1	Sample taken	Momentary push button
Switch 3	Gas Sample #2	Sample taken	Momentary push button
Switch 4	Ignitor and preheat	Off -preheat enabled ignitor disabled Momentary on - ignitor enabled preheat disabled	Double pole momentary toggle
Knob 1	Fan Speed (power)	High-low	Potentiometer

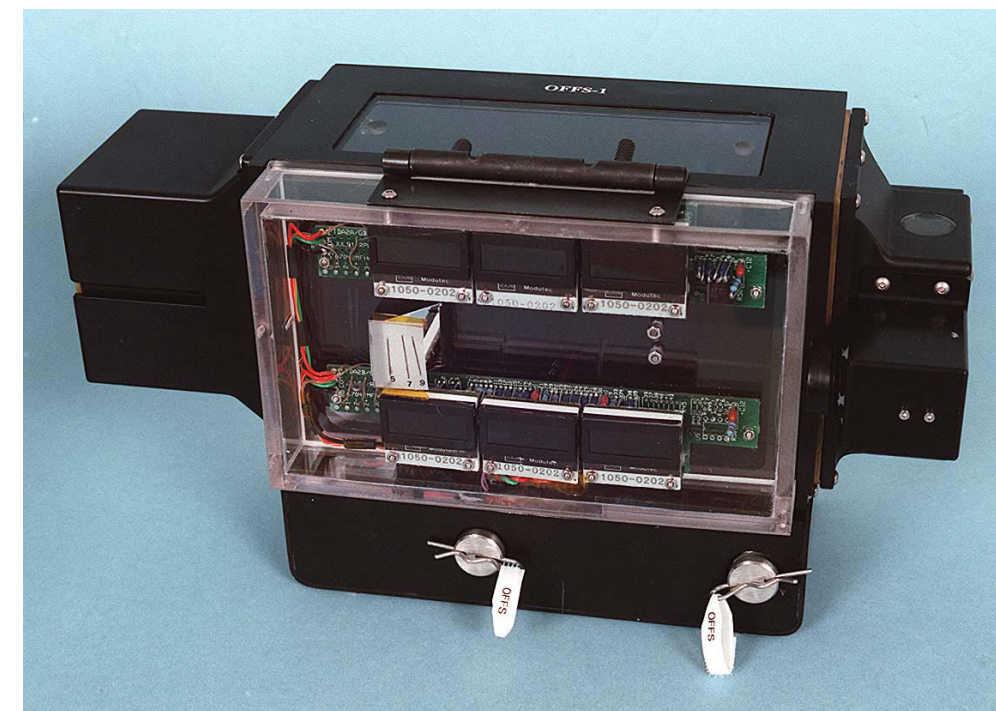

Figure MG-336 Front View of the OFFS Module

96-12676

# PROTEIN CRYSTAL GROWTH (PCG)

## HARDWARE DESCRIPTIONS

There are six pieces of flight hardware associated with the Protein Crystal Growth (PCG) Experiment: the Gaseous Nitrogen (GN<sub>2</sub>) Freezer/Dewar, the Freezer Insert, the Sample Bundles, the Freezer Space, the Velcro Strap, and the Nomex Cover Bag. The assembled flight hardware has a control mass of 19.02 kilograms (kg) and a return control mass of 13 kg.

### GN<sub>2</sub> FREEZER/DEWAR

The GN<sub>2</sub> Freezer/Dewar is cylindrical in shape, 50.8 cm (20 in) in height and 24.38 cm (9.5 in) in diameter. It has a vacuum jacket that provides thermal isolation and calcium silicate next to the internal storage space that absorbs Liquid Nitrogen (LN<sub>2</sub>). As heat is transferred into the GN<sub>2</sub> Freezer/Dewar, the LN<sub>2</sub> vaporizes keeping the storage space at -190°C ± 10°C. The screw-on cap contains a urethane-foam neck plug to reduce heat leakage through the cap. The GN<sub>2</sub> Freezer has no controls to operate; it is therefore passive and does not require crew interaction on orbit.

### GN<sub>2</sub> FREEZER/DEWAR INSERT

The purpose of the aluminum GN<sub>2</sub> Freezer Dewar Insert is to contain the sample bundles. The design is a sealed unit, equipped with two Pressure Relief Valves set at 3.81 atmospheres (56 psi) to prevent an overpressure hazard. The GN<sub>2</sub> Freezer Dewar Insert is cylindrical in shape, 33.4 cm (13.130 in.) in height and 8.42 cm (3.314 in.) in diameter. The insert is placed in the internal storage space of the GN<sub>2</sub> Freezer Dewar for flight.



S95-17684

Figure MG-337 PCG-GN<sub>2</sub> Dewar Bag and Gloves



S80-41753

Figure MG-338 PCG-GN<sub>2</sub> Dewar Out of the Bag



STS81-358-002

Figure MG-339 PCG-GN<sub>2</sub> Dewar in Location



STS84-373-005

Figure MG-340 PCG-GN<sub>2</sub> Dewar in Mir

D.I.D.

Protein Crystal Growth Project  
Gaseous Nitrogen Freezer

**Principal Investigator:**  
Alex McPherson  
University of California-  
Irvine  
Professor of Molecular  
Biology and Biochemistry  
(714)824-1931

Ron King (PED)  
(205)544-0044

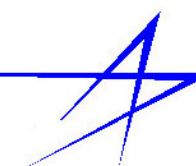

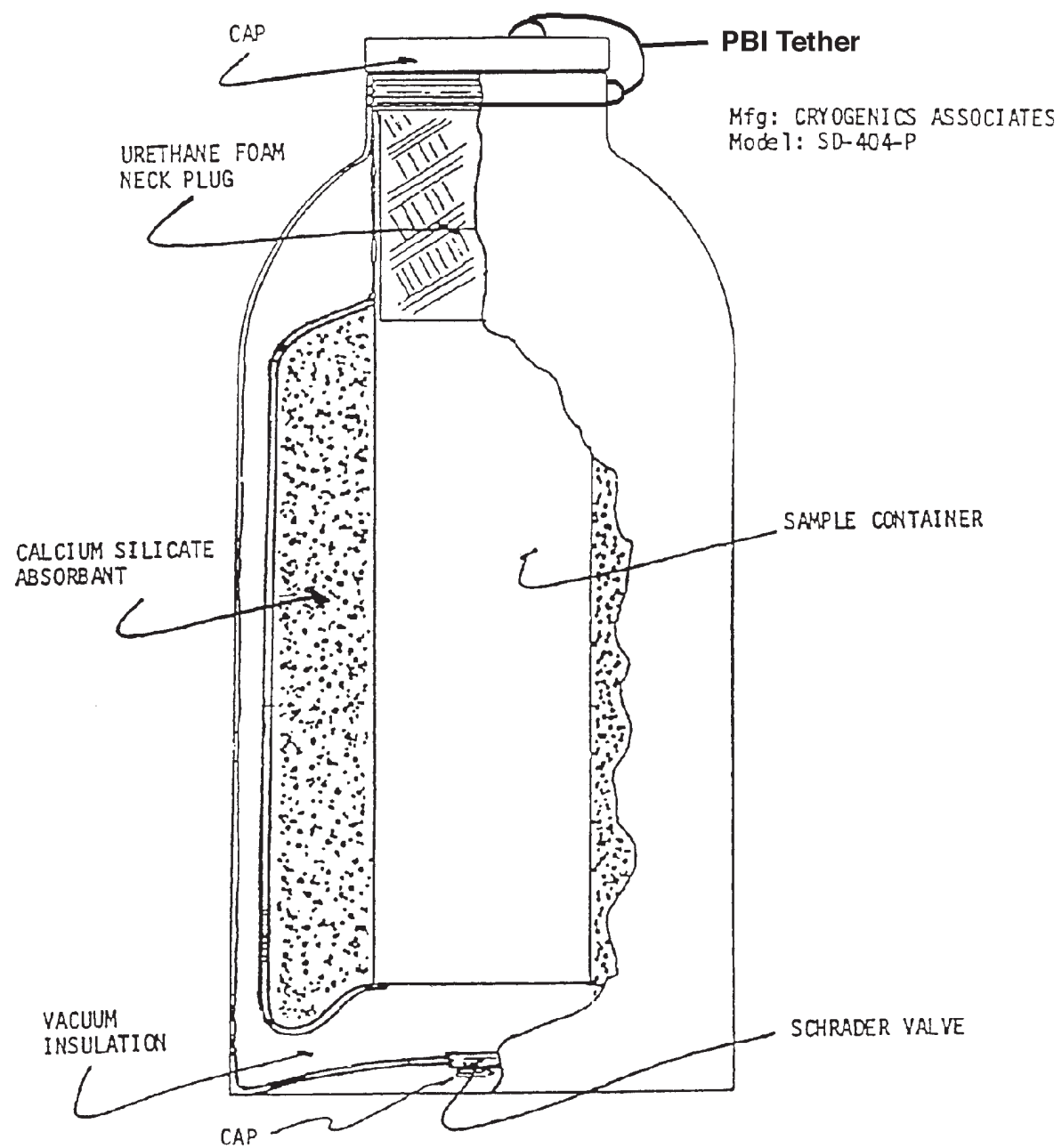

Figure MG-341 GN<sub>2</sub> Freezer Dewar

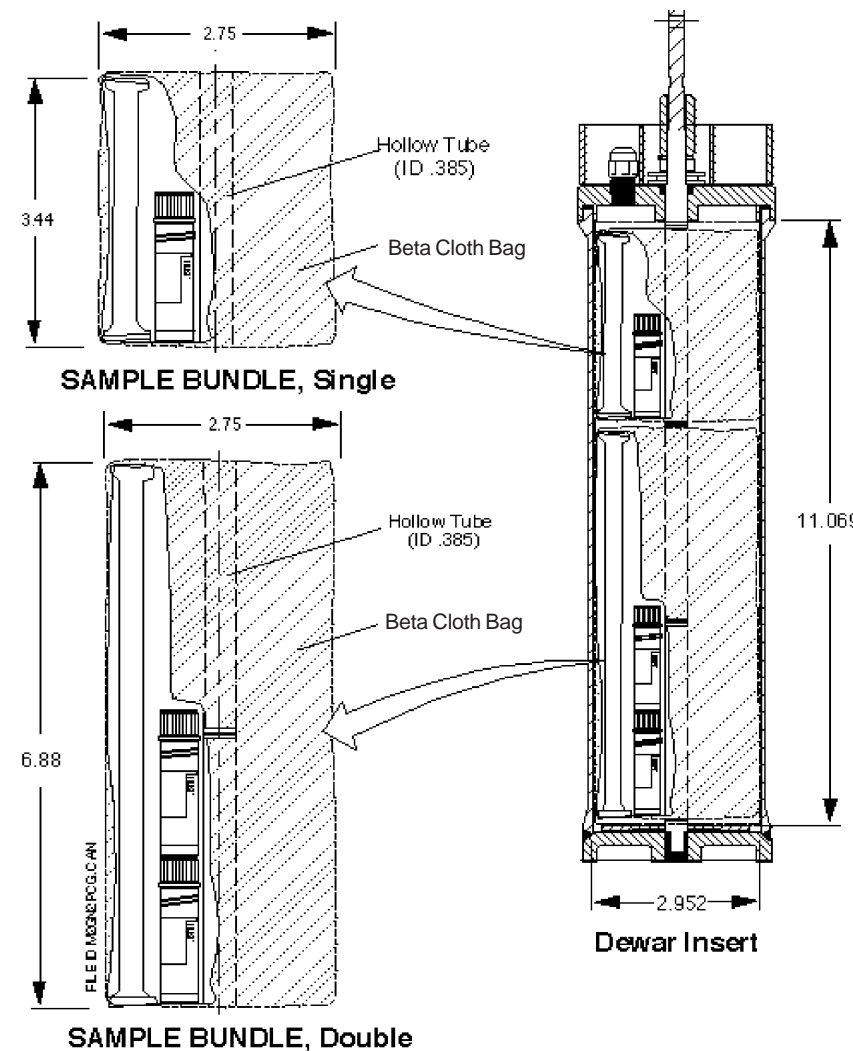
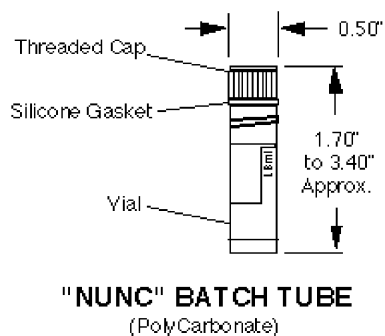
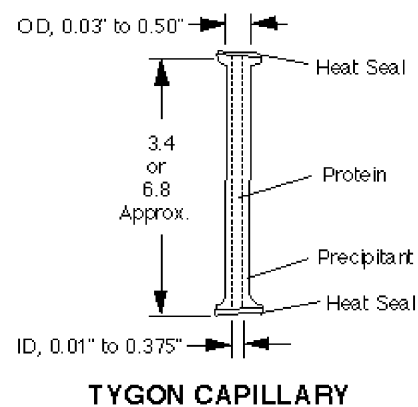

Figure MG-342 Sample Bundles

### SAMPLE BUNDLES

The Sample Bundles are provided by the experimenter. The liquid-liquid diffusion samples are prepared, flash frozen, and assembled into the Sample Bundles by the experimenter.

Each sample is contained either in a small Tygon tube, which is heat sealed at each end, or in a Nunc tube, a cryogenic test tube with a threaded cap incorporating an O-ring seal. The maximum quantity of samples is 350. Individual samples

range in size from 5 microliters to 5 milliliters. These samples are placed in a bag made of Beta Cloth Material (not the Nomex GN<sub>2</sub> Freezer Dewar Bag) to create the Sample Bundles. These bundles are placed in the GN<sub>2</sub> Freezer Dewar Insert for flight. The frozen insert with samples is not opened after it is loaded and sealed at the University of California. The envelope for the Sample Bundles is 28.1 cm (11.069 in) in height and 7.5 cm (2.952 in) in diameter. \*

### GN<sub>2</sub> FREEZER/DEWAR EXPERIMENT ASSEMBLY

P/N: 96M78975-1  
 Qty: 1  
 Mass: 19.02 kg  
 Power: 0  
 x,y,z: 50.8 x 24.38 x 0 cm  
 Loc: Kvant, TBD  
 DID#: SLM46109809

Physical Requirements:  
 Place in location of least disturbance away from direct sunlight

Temperature:  
 18 - 26 °C

Gas Environment Composition:  
 Nitrogen - up to 78%  
 Oxygen - up to 40%  
 Carbon Dioxide - up to 3%  
 Helium - up to 0.01%  
 Hydrogen - up to 2%

Pressure:  
 450 - 970 mmHg

Relative Humidity:  
 10 - 80% within temp range of 5 - 40 °C (assuming no water condensation on h/w surface)

Radiation Specifications:  
 Considered protection layer thickness: 1g/cm<sup>2</sup>  
 Doses at flight duration of - 3 years galactic space radiation:  
 radiation belts - 150 rad  
 sun flares - 40 rad

Maximum dose rate:  
 galactic space radiation, radiation belts - up to 5x10<sup>-3</sup> rad/h  
 sun flares - up to 2.5 rad/h

Expected Operational Life:  
 1 year

Storage Life:  
 7 years

Hardware Life:  
 5 years



# QUEENS UNIVERSITY EXPERIMENT FOR LIQUID DIFFUSION (QUELD) II

## QUELD II SYSTEM OVERVIEW

The key features of the QUELD II system are:

- Maximum operating temperature of 900 °C
- Maximum temperature gradient of 70 °C/cm
- Isothermal sample exposure profile
- Temperature gradient exposure profile
- Operation over input voltage range of 23 to 32V
- Twin independent channels for increased processing capacity
- Three-zone furnace windings for control of thermal gradients
- Required astronaut crew time of only 5 minutes per sample
- Automatic sample insertion into preheated furnace
- Automatic sample quench
- Complete sample process information set by a single, two-digit code front panel
- All sample processing codes present on replaceable memory modules

The layout of the hardware is straightforward with no complicated packaging limitations. The left half of the QUELD enclosure contains the equipment electronic components (Input/Output [I/O] modules, power module, Central Processing Unit [CPU], instrument controls). The right half of the enclosure contains the twin furnace modules, twin Quench Blocks (QBs), and twin linear drives to insert and remove the samples. The QUELD furnace can process one or two samples sequentially, depending upon the experiment. The CPU and complementary I/O modules are plugged

directly into a rigid backplane designed specifically for use with the process control units. This backplane contains all the necessary communication hardware and wiring between the units. The backplane is securely mounted to the structural rails of the enclosure.

The furnace module, which contains the two furnace cores, is inserted to one of the enclosures and secured in place using mounted hardware.

The QB assemblies are positioned at the end of this furnace module. Sample insertion and removal is performed by the twin linear drives mounted below the furnace module.

The front panel of the enclosure contains all the user interface components required for operation by the astronaut, plus access to the sample mounting locations.

The design of the QUELD II system focuses on minimizing crewmembers' time. Sample processing profiles are present on a memory card, minimizing set-up time and reducing the chance of inadvertent error. Following sample loading, all sample processing is performed automatically, including sample quench.



Figure MG-344 QUELD Hardware

S96-18292



Figure MG-343 QUELD Front Panel

S96-18365

**Principal Investigator:**  
Reginald Smith, Ph.D.  
Queens University  
Ontario  
Professor, Emeritus  
(613)545-2753

Duncan Burnside  
(613)990-0806

### QUELD II FURNACE ASSEMBLY (FA-1)

P/N: S5004R00  
Qty: 1  
Mass: 19.05 kg  
Power: 157 W  
x,y,z: 37.6 x 19.7 x 38.4 cm  
Loc: Priroda, SIC2-II-1

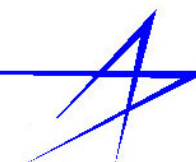

## QUELD II HARDWARE DESCRIPTION

The Priroda version of QUELD contains the following system subcomponents:

- System enclosure
- CPU
- Temperature control module (3)
- I/O module
- Communication module
- Memory module
- Furnace module
- Samples
- Sample loading actuators
- QB assembly
- MIM interface components
- QUELD II Connections

The following sections describe these subcomponents in more detail.

### SYSTEM ENCLOSURE

The enclosure is a standard commercial product. The rigid design is based on a self-supporting frame that consists of two aluminum die-cast bezels joined by aluminum side extrusions. The case is equipped with removable covers. The right side of the front panel contains a door that provides access to the furnace for sample loading.

### CPU

The system employs a standard CPU module with a wide variety of features and capabilities for applications, high reliability and maintainability, and the ability to meet the need for future change and system expansion.

### TEMPERATURE CONTROL MODULE

Temperature control is defined by the QUELD II CPU and maintained by three I/O temperature modules. All control information, such as setpoints and ramp rates, is recorded as part of the sample profile and sequentially downloaded to the appropriate temperature according to predetermined time intervals.



Figure MG-345 QUELD Kit

S96-09688



Figure MG-346 QUELD Sample Adjusters Used to Manually Insert or Remove Samples

S96-18358



Figure MG-347 QUELD Channel Controls

S96-18345

### I/O MODULE

All of the thermal and mechanical operations are ultimately the responsibility of the CPU. Sensors, thumbwheel switches, and push buttons are read via an I/O module that is connected to the microcontroller CPU through the CPU backplane. The error and status indicator lamps (Light-Emitting Diodes [LEDs]) are illuminated by the I/O module.

### COMMUNICATION MODULE

Housekeeping, as well as furnace zone temperature information, is available via the data connector or the front panel. The connector serves to send analog data to MIM.

### MEMORY MODULE

The memory module is a removable data cartridge that contains all the experimental process information for approximately 30 to 50 samples. The memory module is replaced by the astronaut as required to correspond to the sample selection.



## FURNACE MODULE

The furnace module may be operated in isothermal or temperature gradient modes. This is possible by the control of three independent thermal zones in each of the two furnaces. Each zone is a low-inductance, reverse-wound resistance element with corresponding monitoring thermocouple.

## SAMPLES

Specimens are contained in graphite crucibles with spring-loaded, well-fitting caps. These crucibles are enclosed in twin layers of stainless steel.

## SAMPLE LOADING ACTUATORS

The samples are individually inserted and removed from the furnaces via linear drives in a low-profile configuration. These drives are comprised of a robust-traveling slider and mating precision lead screw driven by an attached dc motor via integral gearbox.

## QB ASSEMBLY

Twin Quench blocks are present on the end of the furnace module. The design of the QBs incorporates mechanical actuators to permit individual automatic operation.

## MIM INTERFACE

The mechanical interface with the MIM is achieved by plates that register with the flotor of the MIM.

The electrical interfaces with the MIM are as follows:

- 27V DC power cable
- 9-pin data cable

## DATA COLLECTION AND RECORDING

The data collection is performed by the MIM. In addition to this automated data collection, the crewmembers are required to manually keep a log of QUELD operations conducted.



Figure MG-348 QUELD with Door Ajar

S96-18359

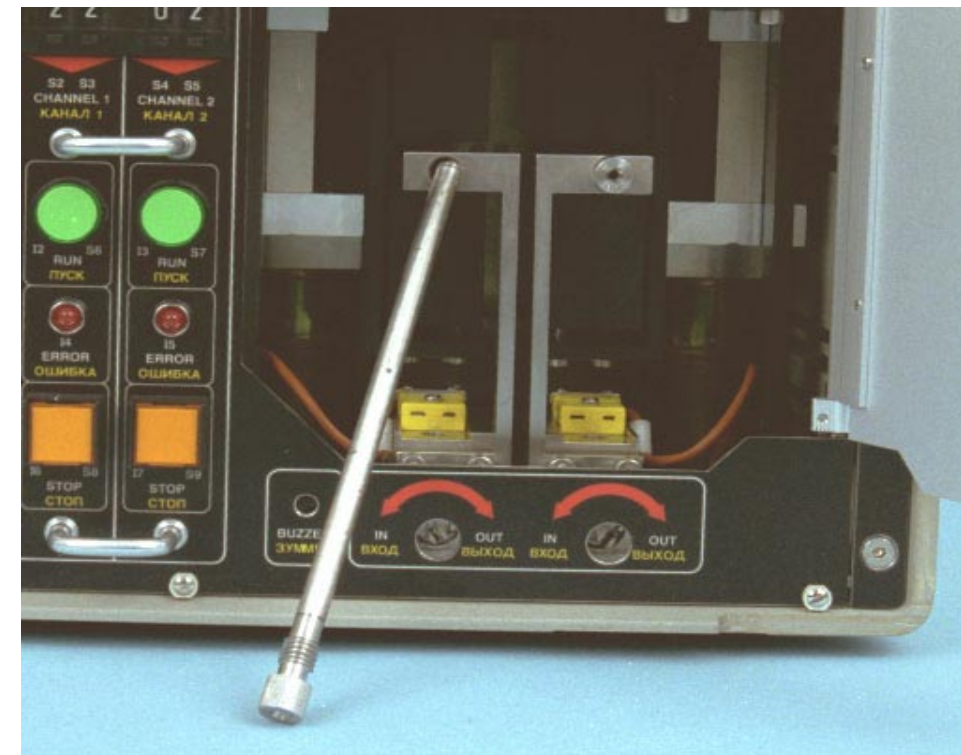

Figure MG-350 QUELD Sample in Front of the Panel

S96-18363

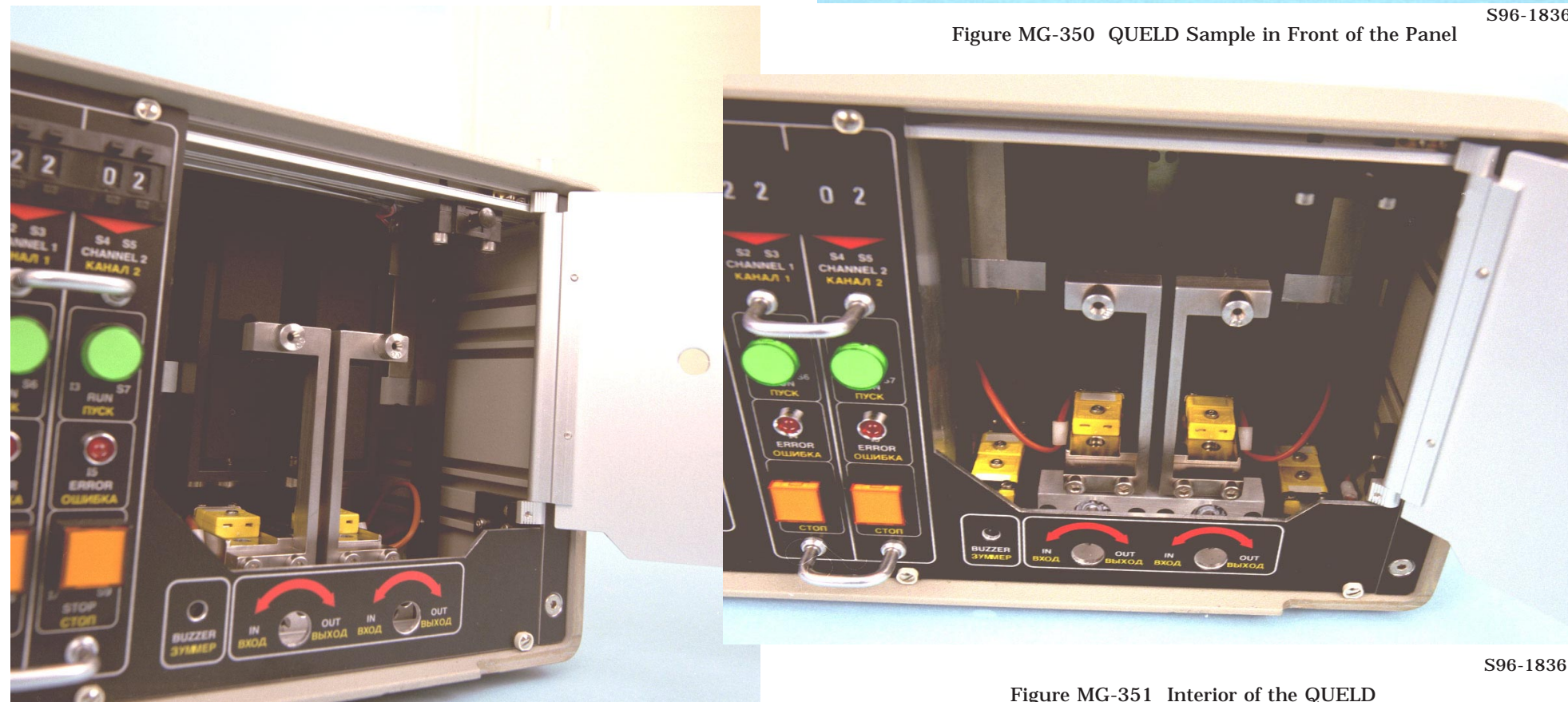

Figure MG-349 QUELD Samples Inserted

S96-18360

Figure MG-351 Interior of the QUELD

S96-18361





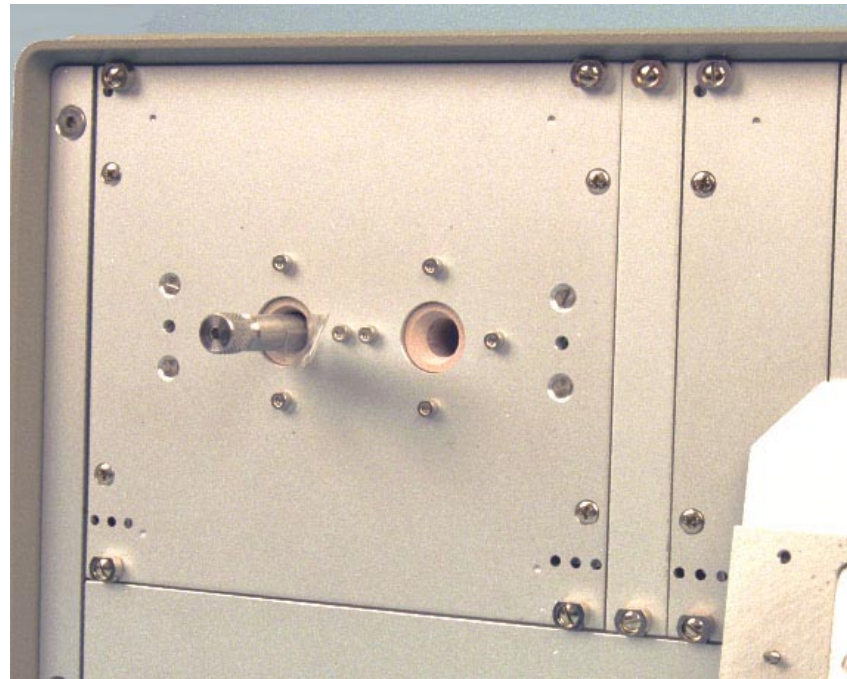
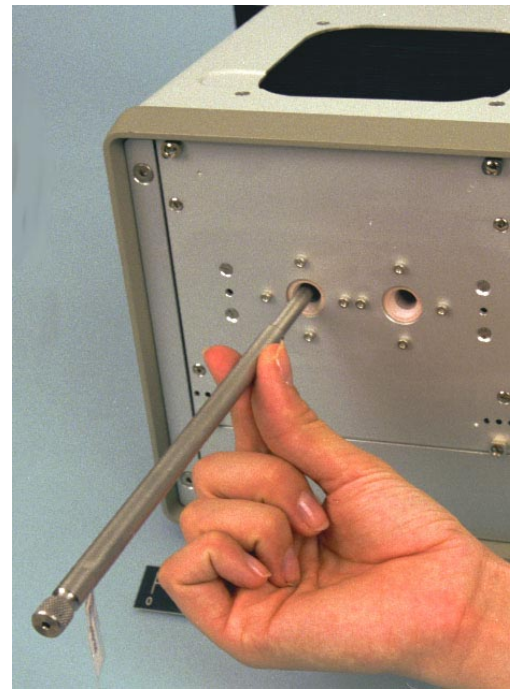

Figure MG-352 QUELD Alignment Tool Inserted S96-18339



S96-18337  
Figure MG-354 QUELD Alignment Tool

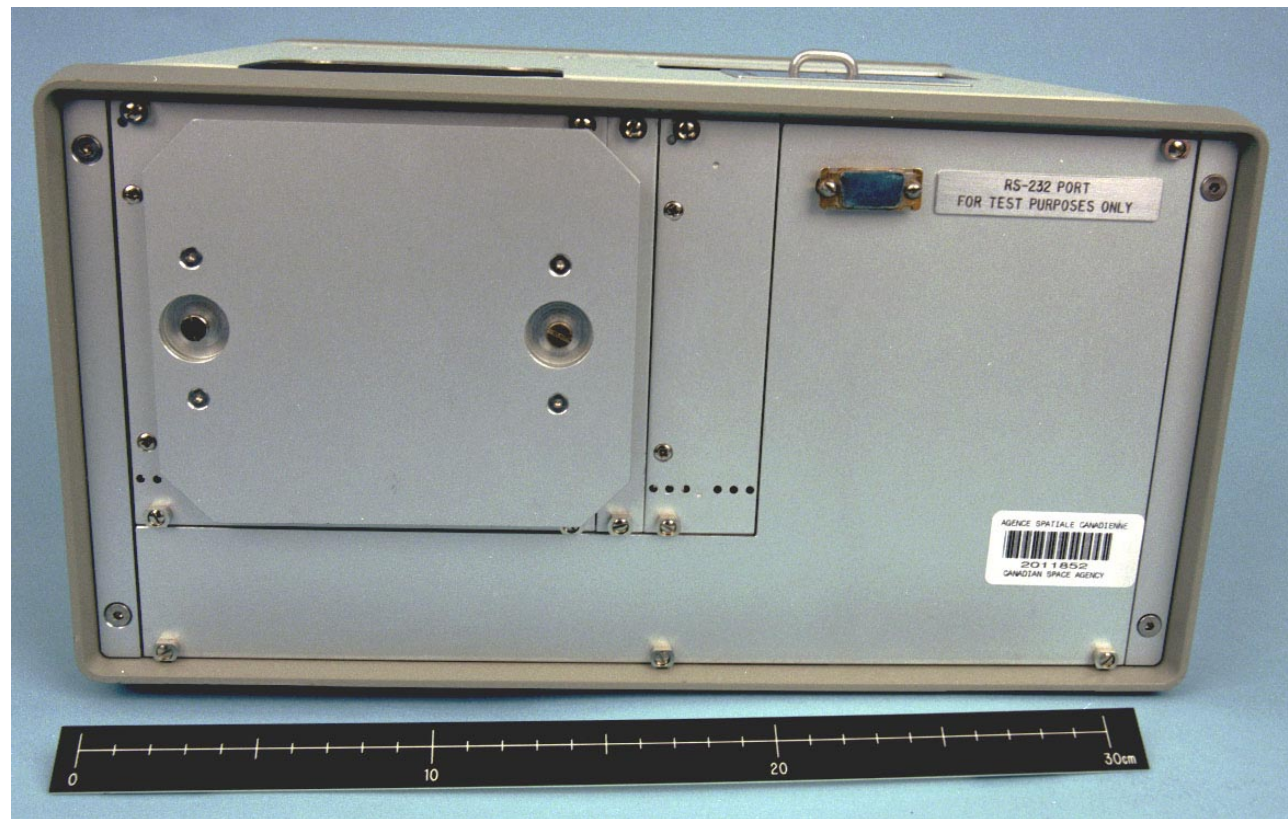

Figure MG-353 Back of QUELD S96-18341

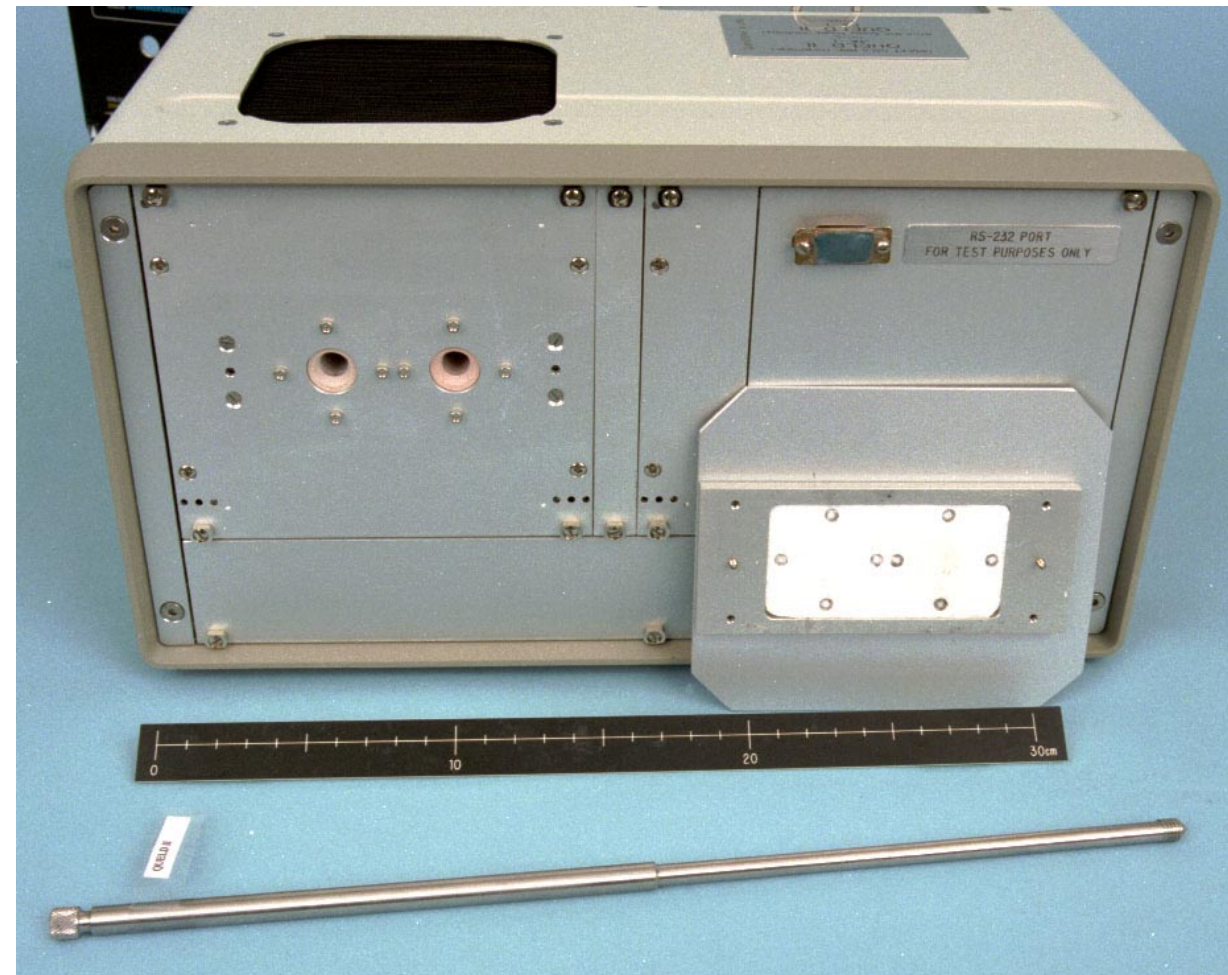
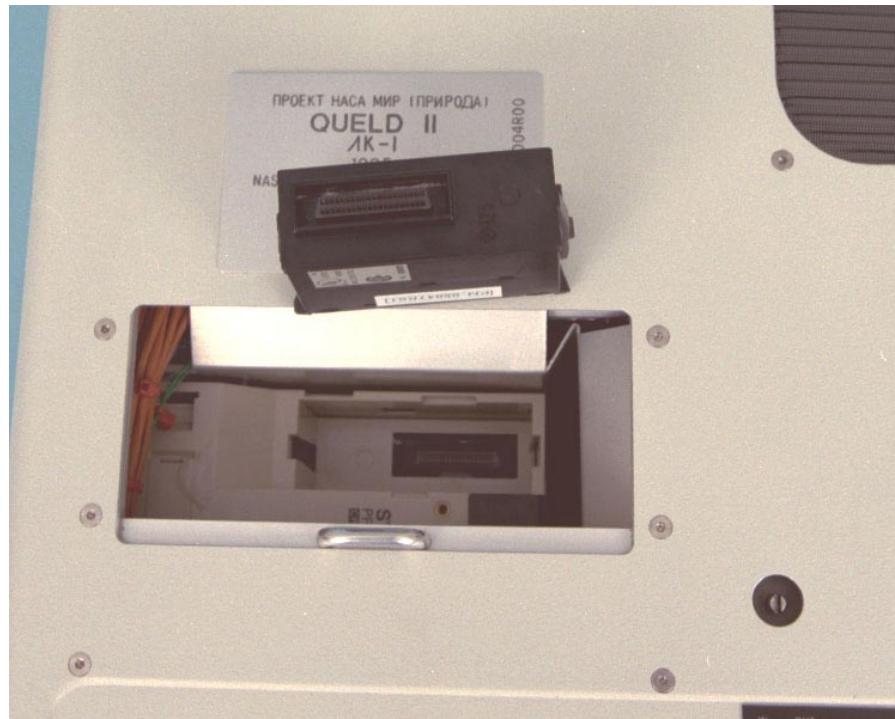
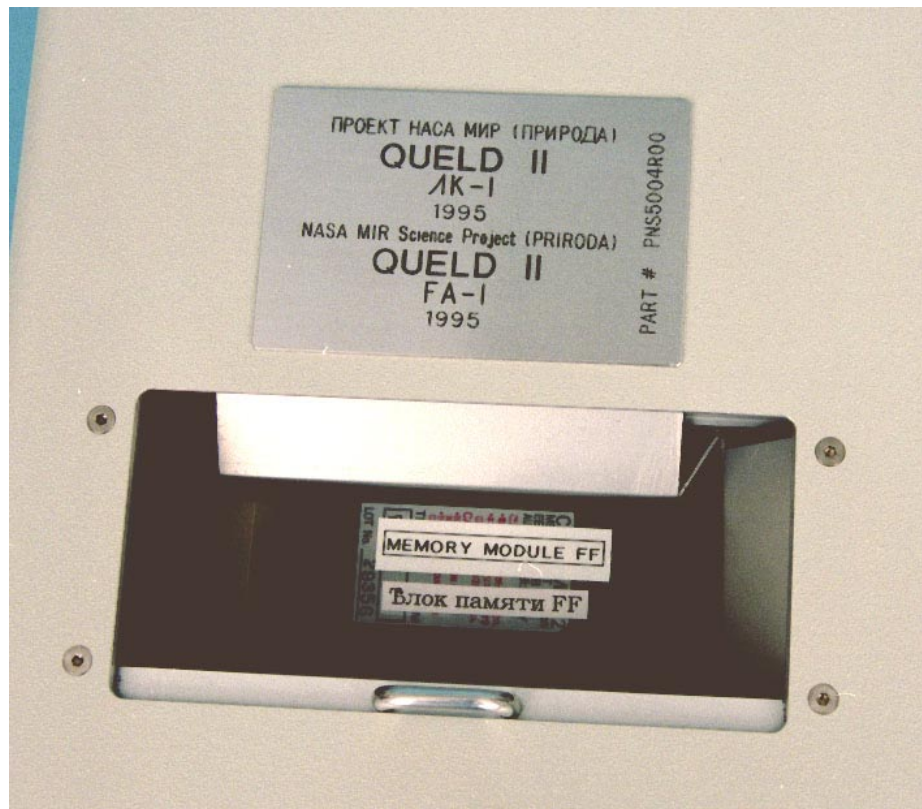

Figure MG-355 Back of QUELD with Cover Removed S96-18340



S96-18343

Figure MG-356 Memory Module Above the Insertion Location



S96-18342

Figure MG-357 Inserted Memory Module



S96-18344

Figure MG-358 Top of QUELD Showing Memory Module Insertion Location

### **SAMPLE PROCESSING**

Sample processing parameters are preprogrammed into the memory module for automatic processing. A summary of sample processing routines is present as Table MG.17.

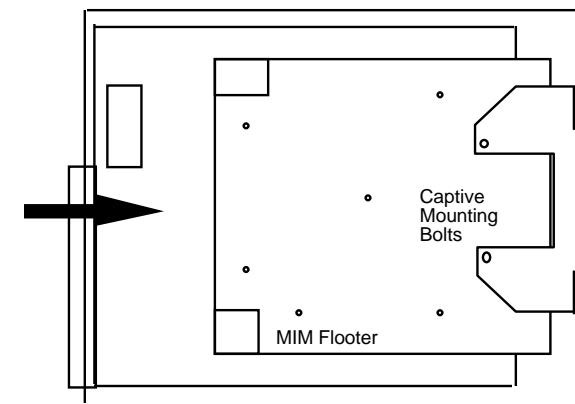

STEP 1. INSTALL MOUNT PLATE 'A'

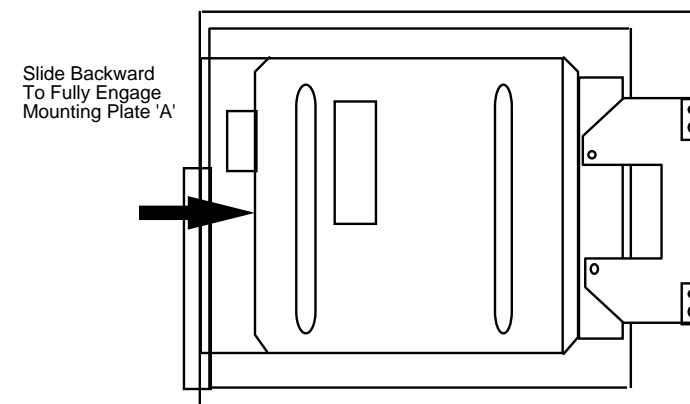

STEP 2. PLACE QUELD II ON MIM AND SLIDE BACKWARDS

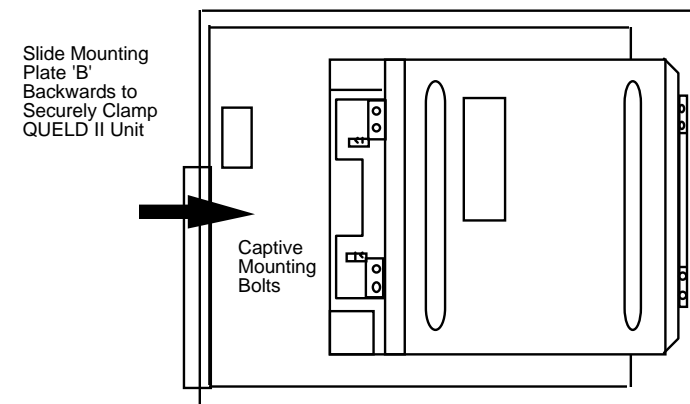

STEP 2. INSTALL MOUNT PLATE 'B'

Slide Backward To Fully Engage Mounting Plate 'A'

Slide Mounting Plate 'B' Backwards to Securely Clamp QUELD II Unit

Figure MG-359

Illustration Describing the Steps to Install the QUELD II System on the MIM Unit



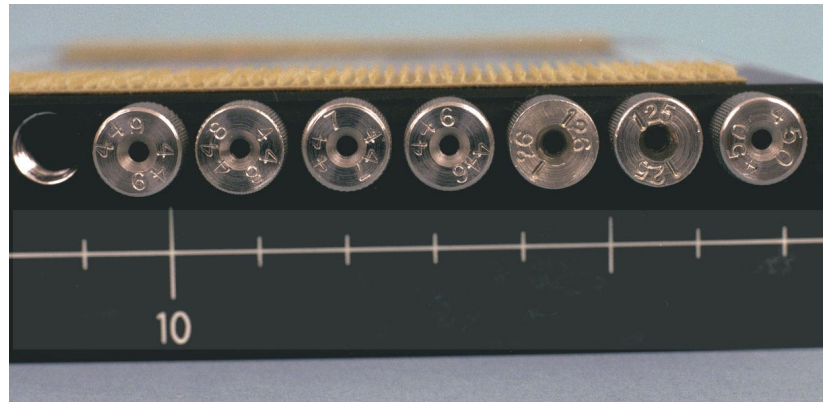

Figure MG-360 QUELD Samples Identification S96-18294



Figure MG-363 Allen Wrench S96-18293

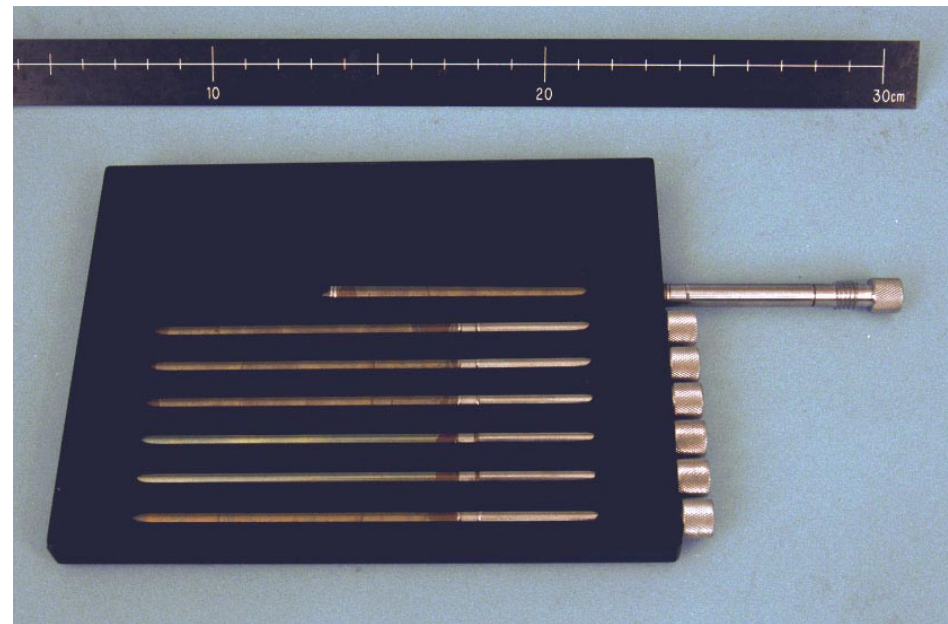

Figure MG-361 Bottom of QUELD Sample Holder S96-18335



Figure MG-364 QUELD Sample Case in Priroda NM23-018-32

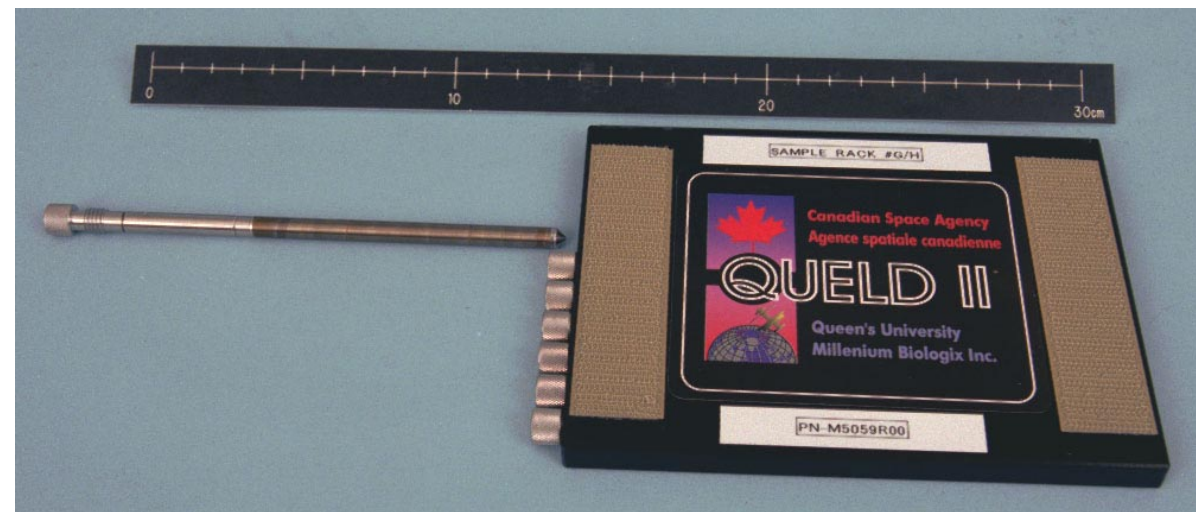

Figure MG-362 Top of QUELD Sample Holder S96-18336

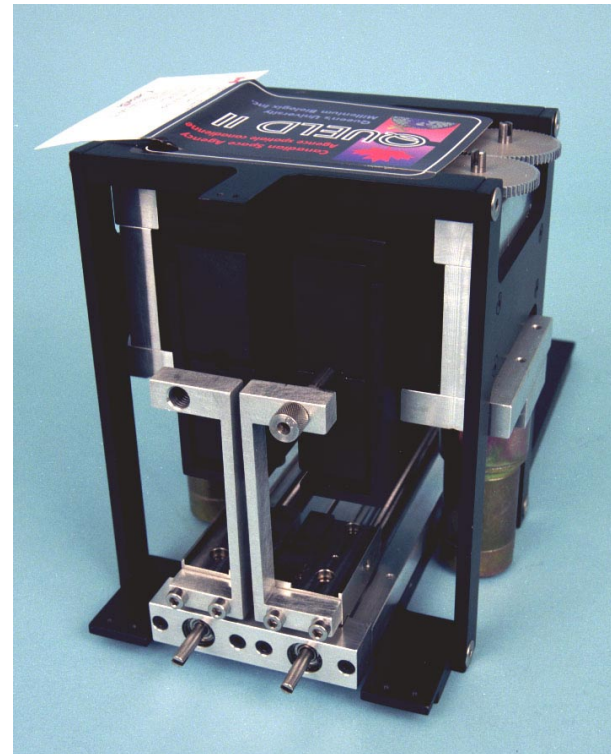

TABLE MG.17  
LISTING OF SAMPLE PROCESSING ROUTINES FOR  
DIFFERENT EXPERIMENTAL CONDITIONS

Description of Automatic Routines	
1.	Isothermal Processing (at Temperature T2).
1.1	Set Temperatures of 3 zones to give $T1 > T2$ (max. 900 °C).
1.2	Power furnace (supply power to 3 zones) (no ramp).
1.3	Control at T1 for a given time to equilibrate (e.g. 30 minutes).
1.4	Move sample into furnace.
1.5	Reduce temperatures in 3 zones to give T2 (e.g., 50 °C reduction) ( $T2 < T1$ , $T2 \sim 300 - 900$ °C).
1.6	Process for a given time.
1.7	Withdraw sample from furnace.
1.8	Operate QB.
1.9	Turn off furnace power.
1.10	Maintain quench condition for at least 5 minutes before unloading.
2.	Gradient Furnace Processing (thermal diffusion and Marangoni Drift).
2.1	Set temperatures of 3 zones to give required gradient and average temperature of $T1 (> T2)$ .
2.2	Power furnace. (supply power to 3 zones — no ramp)
2.3	Wait until the required individual zone temperature settings are reached.
2.4	Move sample into furnace.
2.5	Turn zone temperature down to average T2 ( $< T1$ ).
2.6	Process for a given time.
2.7	Withdraw sample from furnace.
2.8	Operate QB.
2.9	Turn off furnace power.
2.10	Maintain quench condition for at least 5 minutes before unloading.

TABLE MG.18  
LISTING OF CONNECTORS

Connector Label	Connector Identification	Connector Description
J1	Data connector	9 line 'D' socket
J2	Power connector	3 line socket



S96-18291  
Figure MG-365 Replacement QUELD Interior

### DISPLAYS AND CONTROLS

The QUELD II system has two electrical connections, labeled J1 and J2. The identification and description of each connection is identified in Table MG.18.

The QUELD II system has 9 control switches, labeled S1 through S9. The functions of these switches are identified in Table MG.19.

The QUELD II system has seven indicator lights, labeled I1 through I7. The description and activation of each indicator is identified in Table MG.20. \*

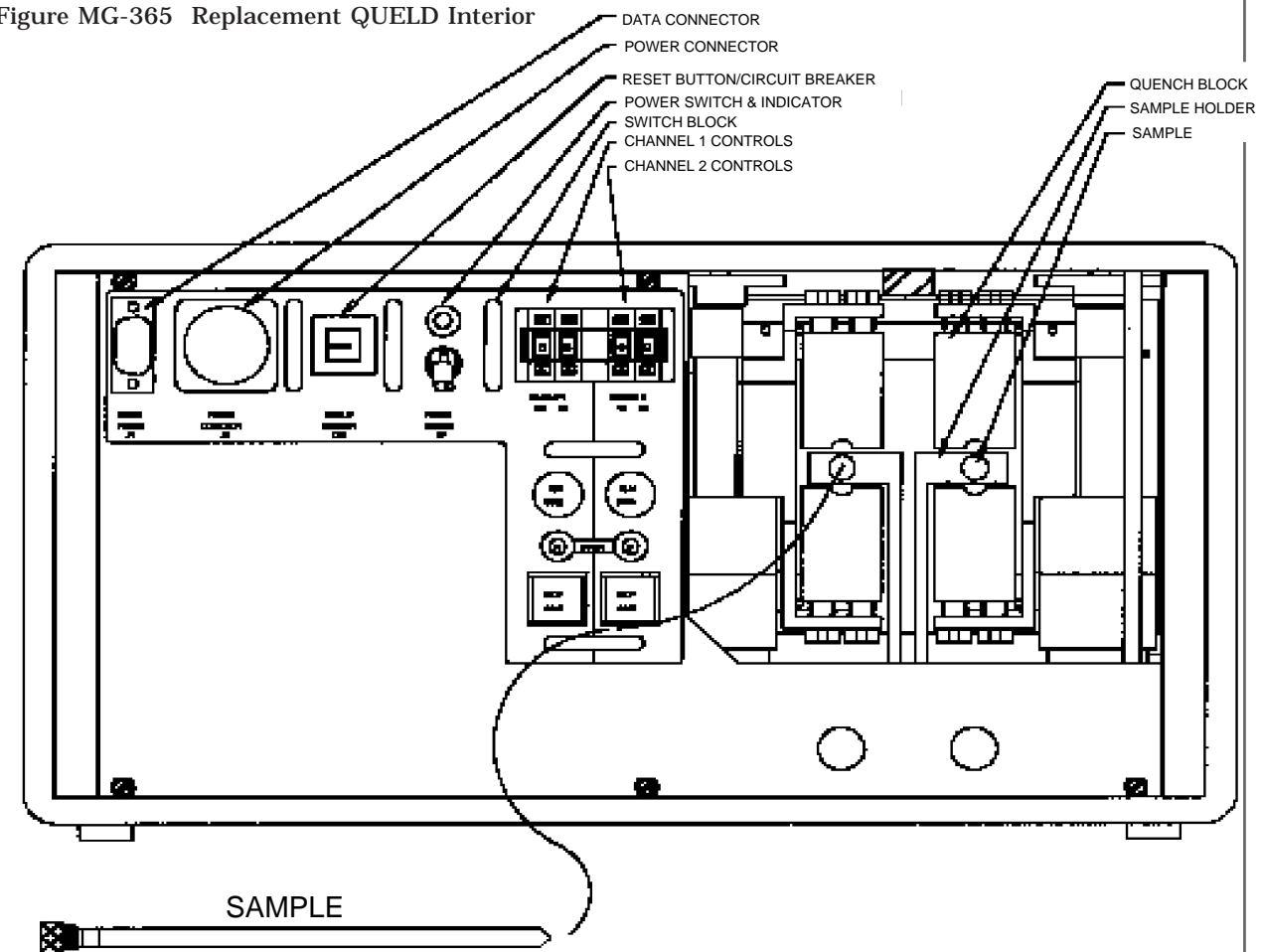

Figure MG-366 QUELD Front Panel Drawing



TABLE MG.19  
LISTING OF SWITCH FUNCTION AND ACTIVATION

Switch Label	Switch Function	Switch Activation
S1	Main power switch	Pull out and lift up to turn on. Pull out and push down to turn off.
S2	Channel 1 first digit selector	Depress upper or lower to increment or deincrement.
S3	Channel 1 second digit selector	Depress upper or lower to increment or deincrement.
S4	Channel 2 first digit selector	Depress upper or lower to increment or deincrement.
S5	Channel 2 second digit selector	Depress upper or lower to increment or deincrement.
S6	Channel 1 RUN activation	Depress push-button switch to start processing.
S7	Channel 2 RUN activation	Depress push-button switch to start processing.
S8	Channel 1 STOP activation	Depress push-button switch to stop processing in a contingency situation.
S9	Channel 2 STOP activation	Depress push-button switch to stop processing in a contingency situation.
CB	Circuit breaker	Automatic with reset.

TABLE MG.20  
LISTING OF INDICATOR LIGHT DESCRIPTION AND ACTIVATION

Indicator Label	Indicator Description	Indicator Activation
I1	System status indicator	Illuminates green when system on.
I2	Channel 1 RUN indicator	Integral with the S6 push-button switch. Illuminates green when Channel 1 is in RUN mode.
I3	Channel 2 RUN indicator	Integral with the S7 push-button switch. Illuminates green when Channel 2 is in RUN mode.
I4	Channel 1 ERROR indicator	Illuminates red when an error condition has been detected in the operation of Channel 1.
I5	Channel 2 ERROR indicator	Illuminates red when an error condition has been detected in the operation of Channel 2.
I6	Channel 1 STOP indicator	Integral with the S8 push-button switch. Illuminates yellow when Channel 1 is in STOP mode.
I7	Channel 2 STOP indicator	Integral with the S9 push-button switch. Illuminates yellow when Channel 2 is in STOP mode.

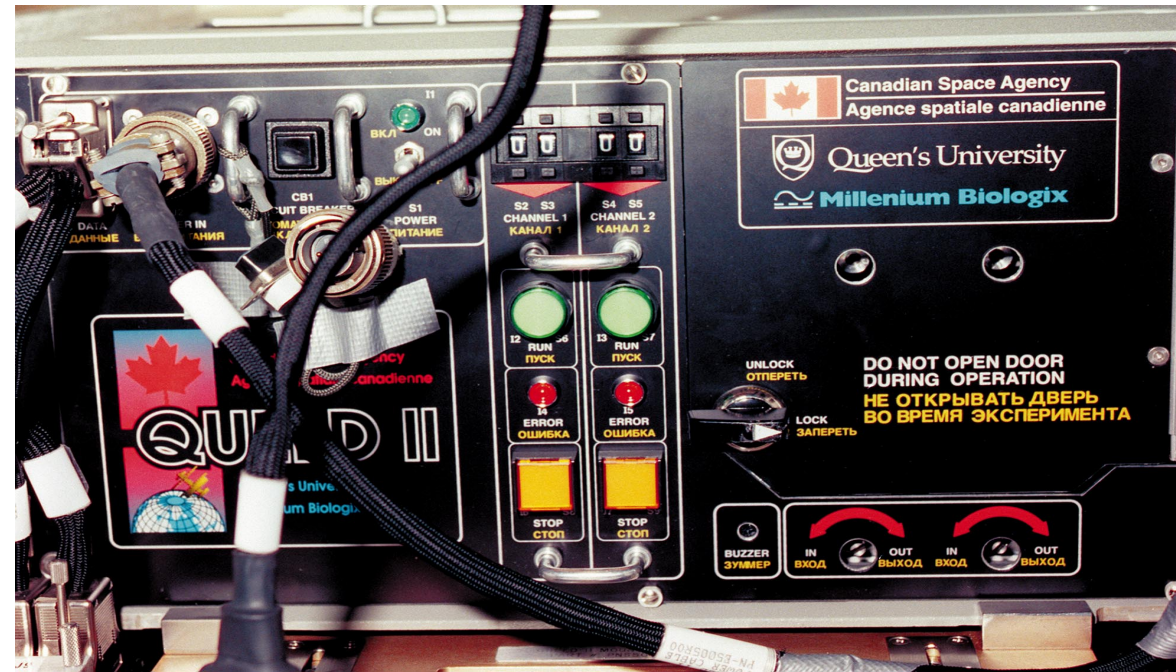

Figure MG-367 QUELD Front Panel

NM23-018-27

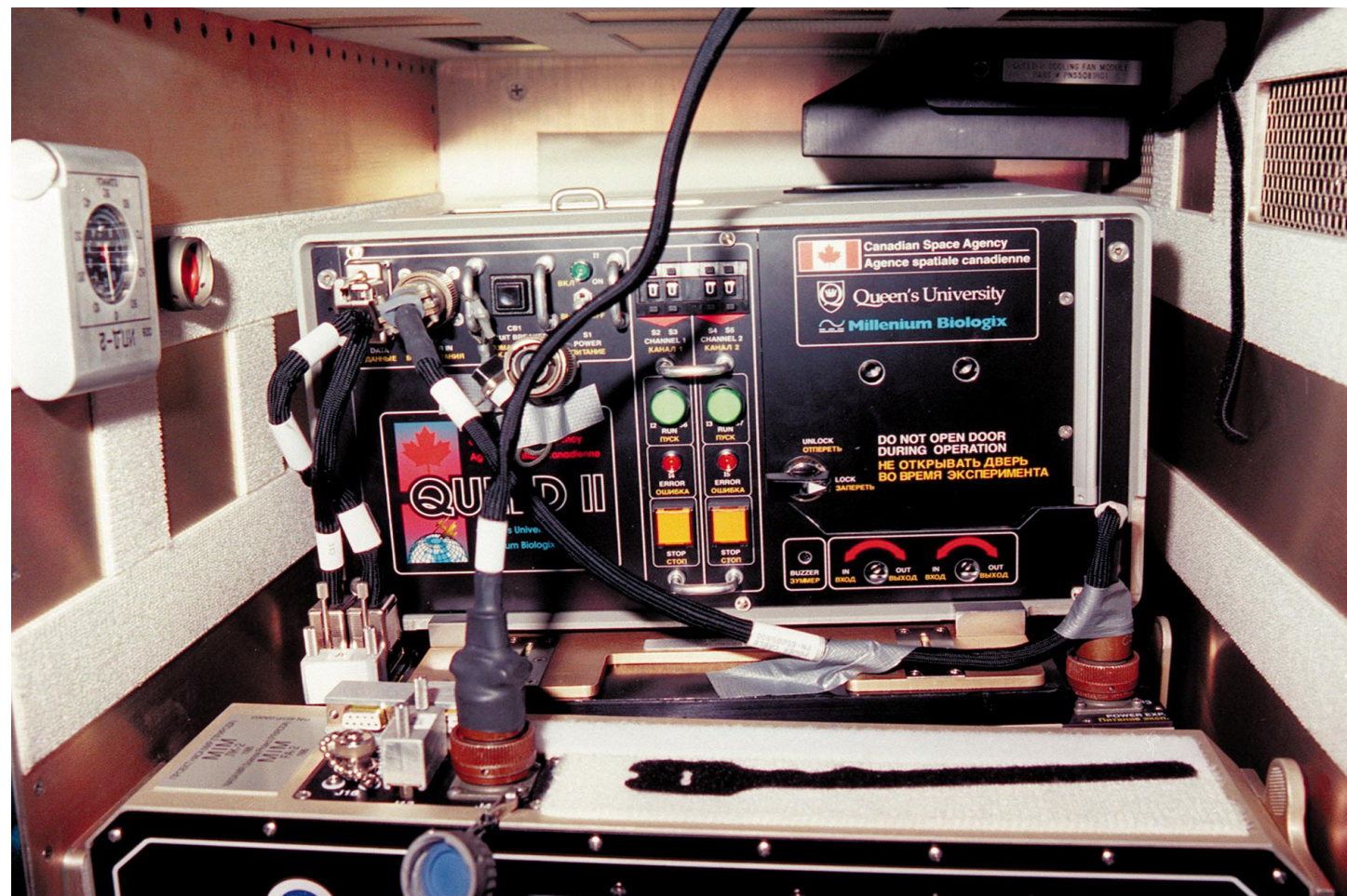

Figure MG-368 QUELD on Top of the MIM

NM23-018-28

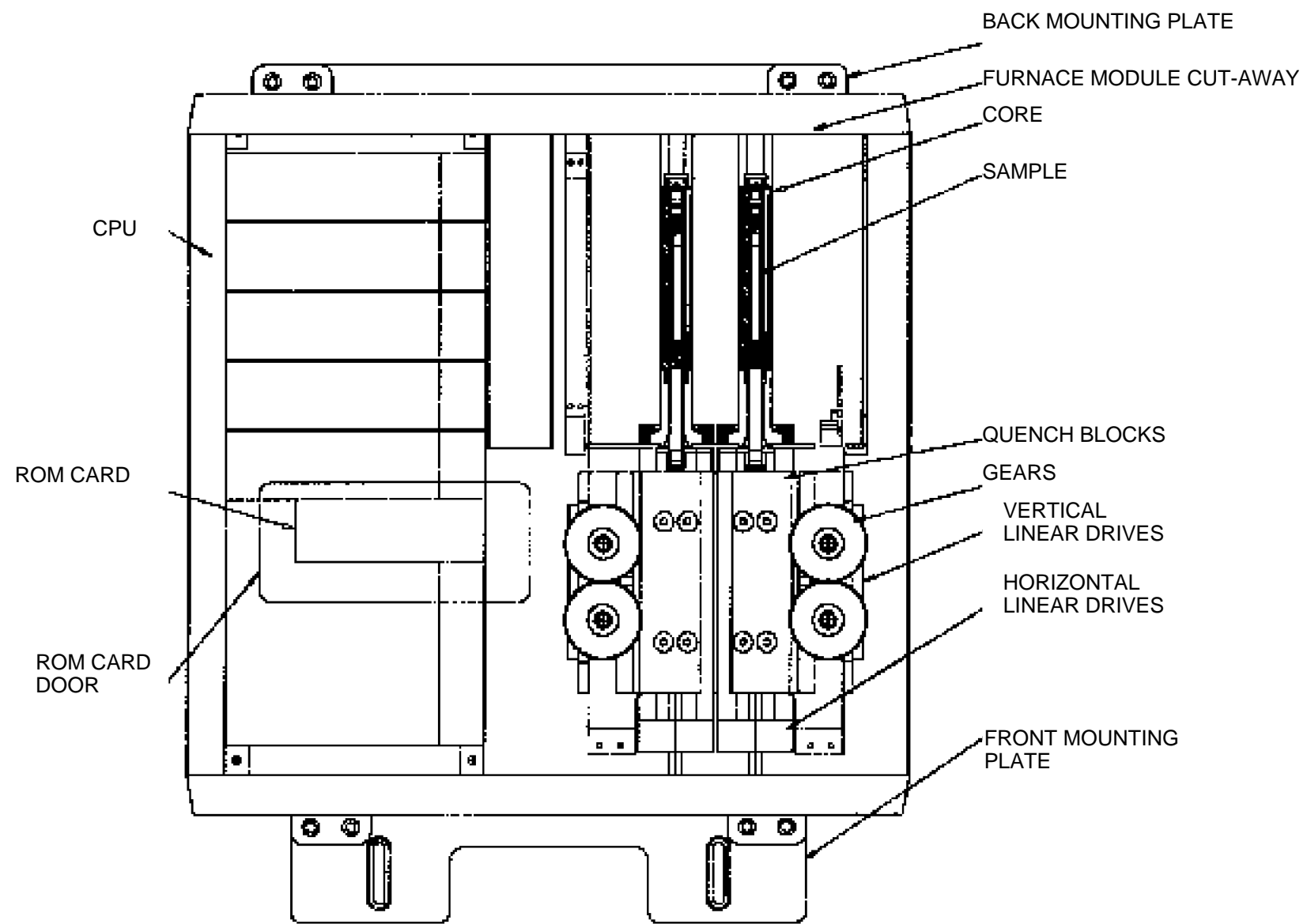

Figure MG-369 Illustration of the Internal Layout of the QUELD II System

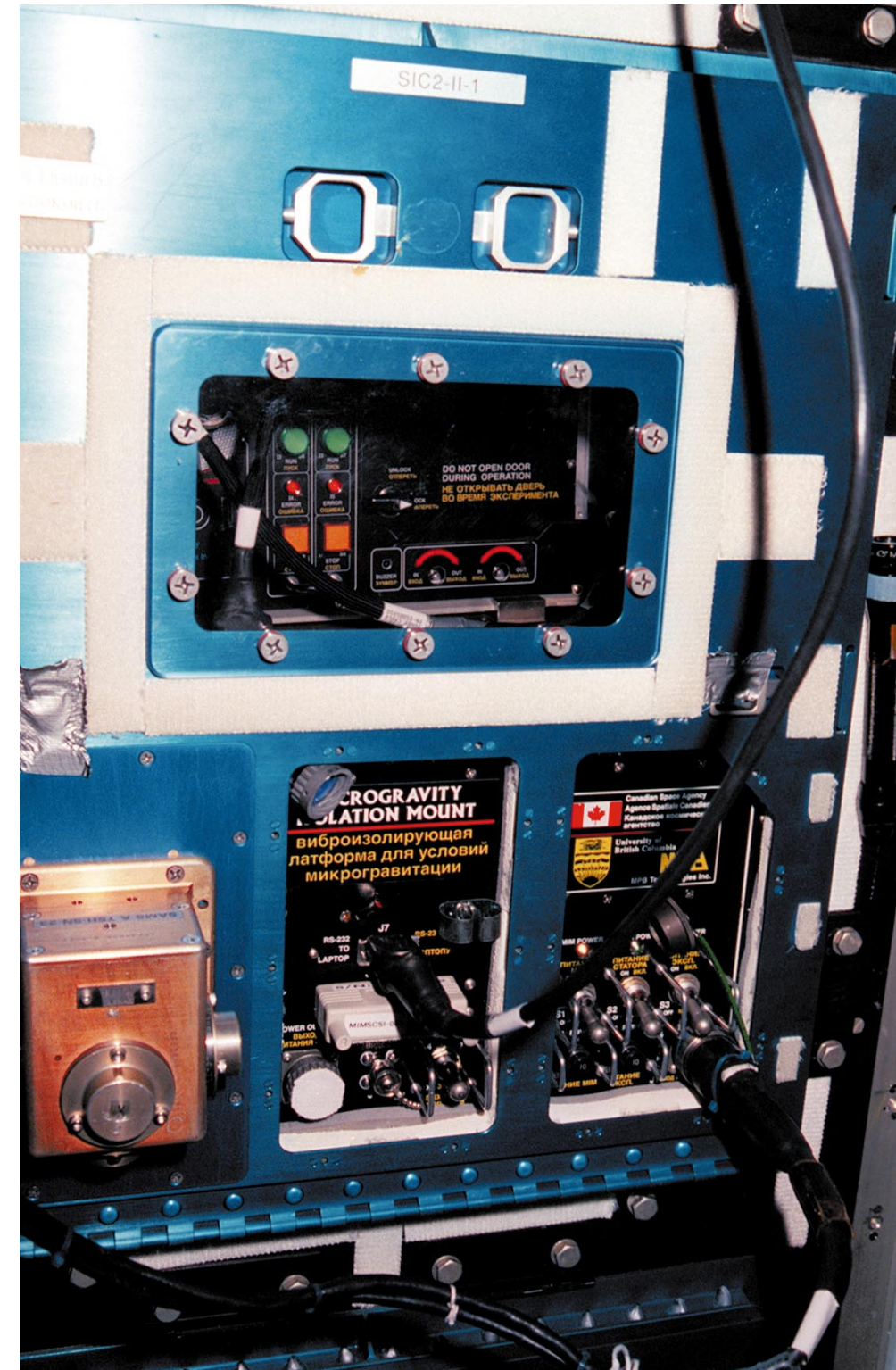

Figure MG-370 QUELD in MIM

NM23-018-26

# SPACE ACCELERATION MEASUREMENT SYSTEM (SAMS)

## EXPERIMENT DESCRIPTION

The Space Acceleration Measurement System (SAMS) is an acceleration measurement and data acquisition instrument, not a classical microgravity research experiment. The SAMS consists of a main unit and up to three remotely positioned triaxial sensor heads (TSH). Each TSH contains orthogonally positioned accelerometers, with a threshold sensitivity of 10<sup>-6</sup> g. The main unit contains analog and digital signal processing circuitry and two optical disk drives for storage.

SAMS equipment measures acceleration disturbances in four ranges automatically selected

by a stored software algorithm. The ranges are  $\pm 500$  mg,  $\pm 50$  mg,  $\pm 5$  mg, and  $\pm 500$  mg full scale. It is possible to select a specific range and inhibit the automatic range selection. This requires a serial computer connection to SAMS to interact with an internal menu-driven program of MIPS.

Each TSH and associated analog filter card in the main unit can be pre-selected to measure acceleration in one of six bandwidths. For the Mir Mission, bandwidths of 10 Hz and 100 Hz have been selected, pending approval by the Russian counterpart. Sample rates for the acceleration data are 50 and 500 samples per second, respectively. The data obtained at these sample rates will be approximately 400 megabytes (one double-sided optical disk full) per day.

Disturbances to the on-orbit microgravity environment, typically 10<sup>-6</sup> g to 10<sup>-2</sup> g in magnitude and 10<sup>-4</sup> Hz to 102 Hz in frequency, affect various types of microgravity science experiments.

The MIPS shall provide the time signal requested by SAMS. The MIPS time signal is synchronized to the Mir timing signal. This signal is used to time stamp data.

## SCIENCE OBJECTIVES

1. Provide a time history of the acceleration environment and characterize the features of this environment to improve future experiment design.
2. Measure and record low level perturbations to the microgravity environment at or near microgravity experiment hardware and support the microgravity investigators' research.

## FUNCTIONAL OBJECTIVES

1. Take module acceleration measurements during the performance of microgravity science experiments.
2. Take acceleration measurements to support the SAMS characterization of the Mir microgravity environment. An example would be the docking and undocking of various vehicles.

## HARDWARE COMPONENTS

- Main Control Unit
- TSH (3 main, 1 spare)
- TSH Cables (3)
- Power Cable
- Timing Cable
- Serial Port Cable
- Grounding strap
- Under Voltage and Temperature Protector Cable
- Acceleration Calibration Device
- Optical Disks (43 currently on Mir on STS-89)
- Roll of 3M Double Coated Tape
- Log Book
- Electromagnetic Interference (EMI) Fan Filters (5)
- Data Cable to Connect to the MIPS-1
- Flight Container
- Pliers
- Optical Disk Cases (2)
- Velcro
- Fan EMI Housing Plates (2)
- Fan Air Filters (12)
- Returnable Transport Container
- Soft Container

D.I.D.

SAMS Sensor Head  
Installation

**Principal Investigator:**  
Julio C. Acevedo  
NASA/LeRC/MC 500-  
217  
(216)433-2471

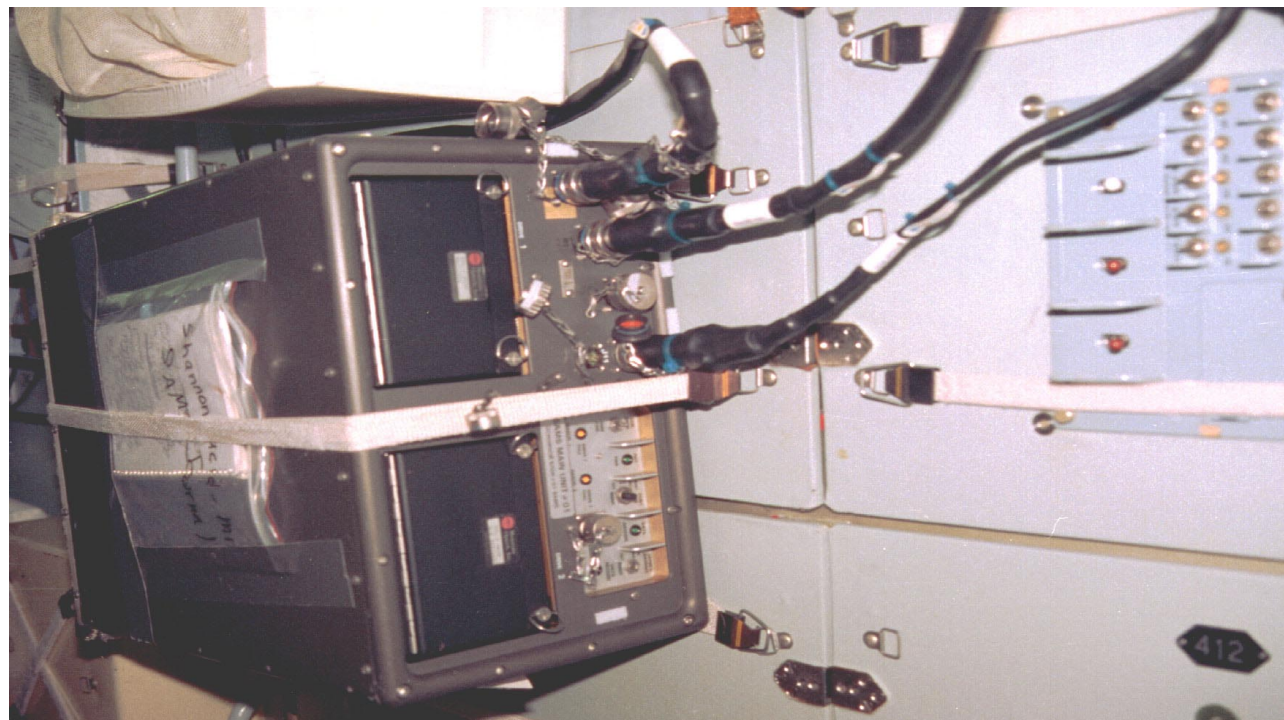

Figure MG-371 SAMS in Location

NM22-230-25



Figure MG-372 SAMS

S94-31771

## HARDWARE DESCRIPTION

SAMS consists of a main control unit, three TSHs, three TSH cables, a power cable, a timing cable, a serial data cable, a grounding voltage and temperature protector cable, and an acceleration calibration device.

A voltage and temperature protector is required. A TSH calibration device is used to measure accelerometer bias, and a log book is used to maintain a log of main unit and TSH locations and SAMS operations. A soft container is used to store the equipment when not in use.

A SAMS serial data cable is required for RS-232 serial communications between SAMS main unit Ground Support Equipment (GSE) test connector and the MIPS-2L computer.

## MAIN CONTROL UNIT

The major components of the main unit include an aluminum support structure, two optical disk drives, a control panel assembly, an electronics control box, aluminum cover panels, a fan, a meter-long ground strap, and miscellaneous internal cabling. The electronics control box provides microprocessor control and data acquisition and conversion. The fan provides cooling for the electronics control box and optical disk drives and is always on when the power switch is in the ON position. The main unit contains analog and digital signal processing circuitry and two optical disk drives for storage.

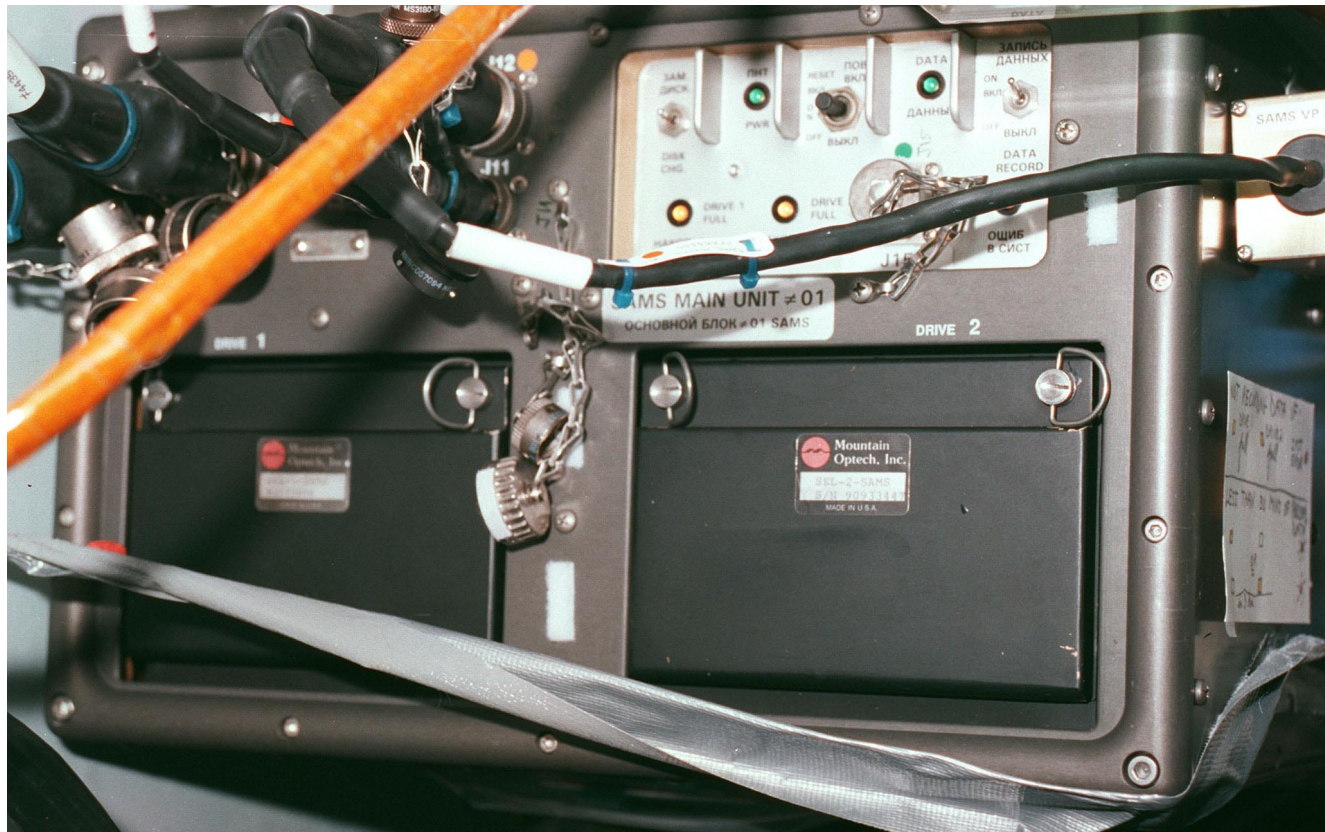

Figure MG-373 SAMS

NM22-6-15



Figure MG-374 SAMS Optical Disks

## Optical Disks

The optical disks use Write Once Read Many (WORM) technology. Each disk has a storage capacity of 200 MB per side (12 hrs) for a total of 400 MB. Crew interaction is required for disk changeout.

To record 24 hours of data, a disk is put in each drive. After 12 hours of data is recorded on the first disk, SAMS starts recording data on the second disk. After 24 hours, the disks must be flipped and the disk change switch must be toggled. After the next 24 hours, the disks must be changed and again the disk change switch must be toggled. Dummy disks are installed during launch, and flight disks are used during on-orbit operations.

Recorded data is time tagged for postmission correlation of Mir events (in Mir time). The main control unit has an internal clock, which requires synchronization to Mir time. This synchronization is accomplished using the MIPS-1 computer. When power is removed from SAMS, the Interrange Instrumentation Group (IRIG) time inside SAMS remains valid for 8 hours. Time synchronization must be performed if SAMS has been powered down for longer than 8 hours.

### MIR SAMS OPTICAL DISK

P/N: CD664459  
 Qty: 43  
 Mass: 2.0 kg each  
 Power: N/A  
 x,y,z: 15.32 x 13.49 x 1.22 cm  
 DID#: SLM46111807





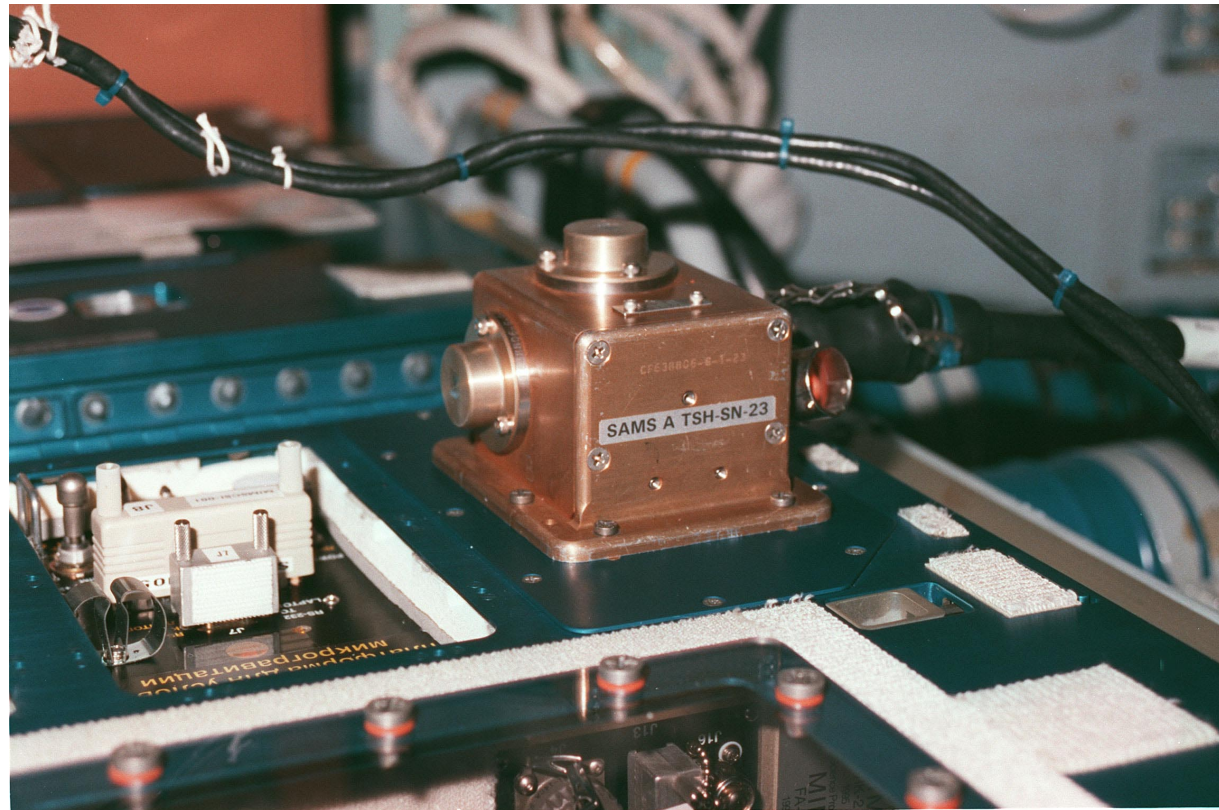

Figure MG-375 Accelerometer Head on the MIM Locker

NM22-6-17

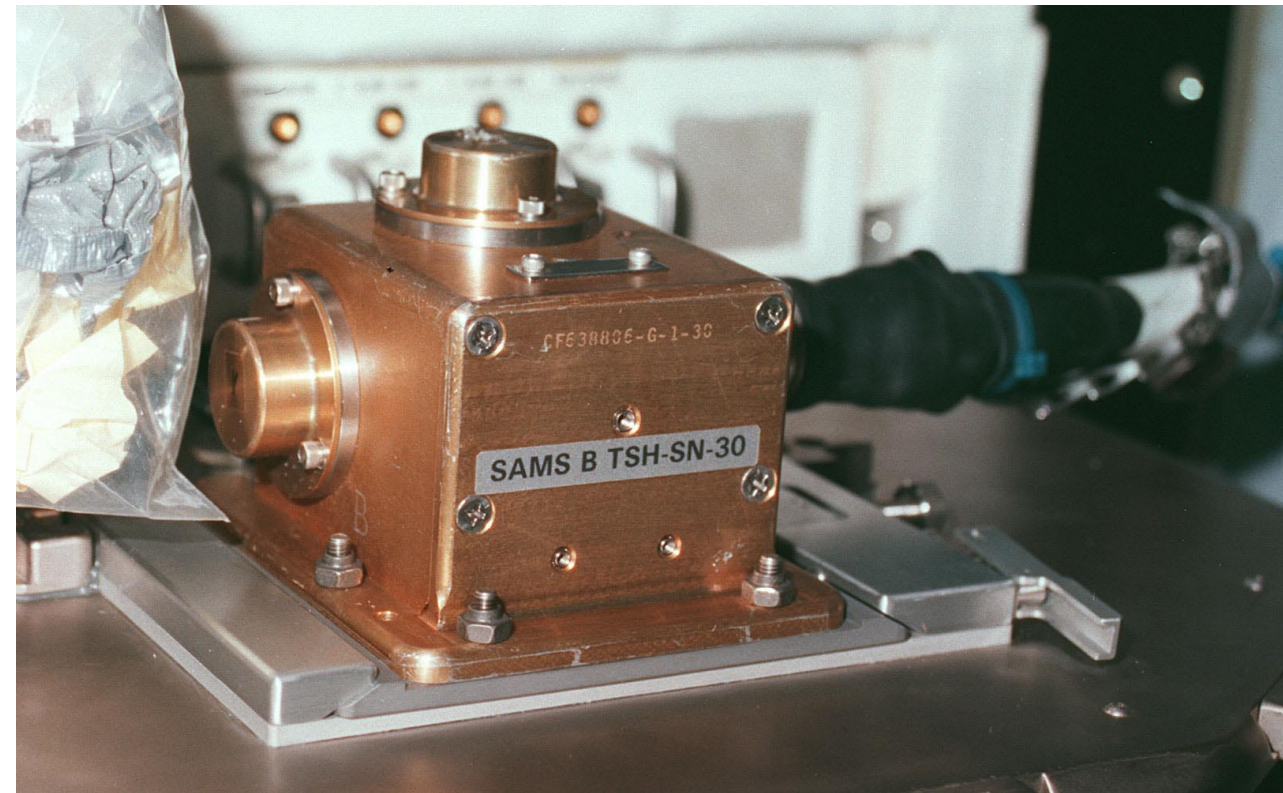

Figure MG-377 Accelerometer Head Mounted Under the MGBX

NM22-6-16

## TSH

Each TSH contains three mutually orthogonal (Sundstrand) accelerometers. The accelerometers use pendulous proof-mass and force rebalance coils to sense accelerations. There are three pre-amp/low pass analog filter (one pole) printed circuit boards contained within each TSH. Each accelerometer contains a temperature sensor for postmission temperature compensation of data.

TSH A is a 100 Hz low pass filter (.01 to 100 Hz) recommended by SAMS to characterize higher frequency disturbances on Mir. TSH B is a 10 Hz low pass filter (.01 to 10 Hz). TSH C is a 2.5 Hz low pass filter (.01 to 2.5 Hz). The spare TSH is a 100 Hz low pass filter.

Three cables connect the SAMS main unit to the TSHs. Data transmitted between these units include accelerometer output, temperature sensor output, and control signal input, all of which are time stamped in the main unit.

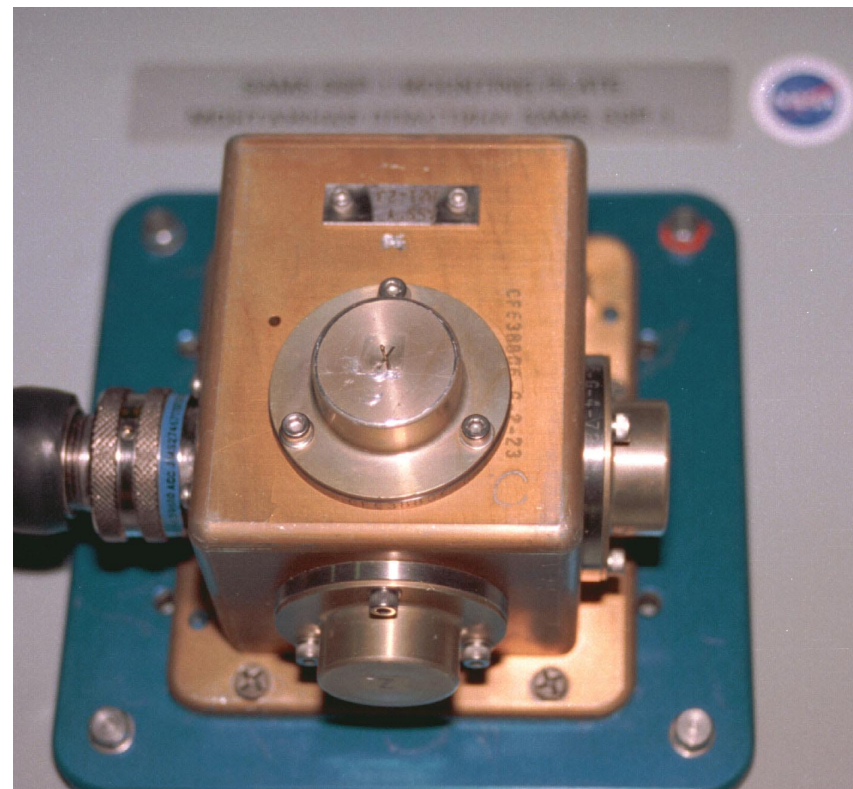

Figure MG-376 Accelerometer Head

NM22-23-19

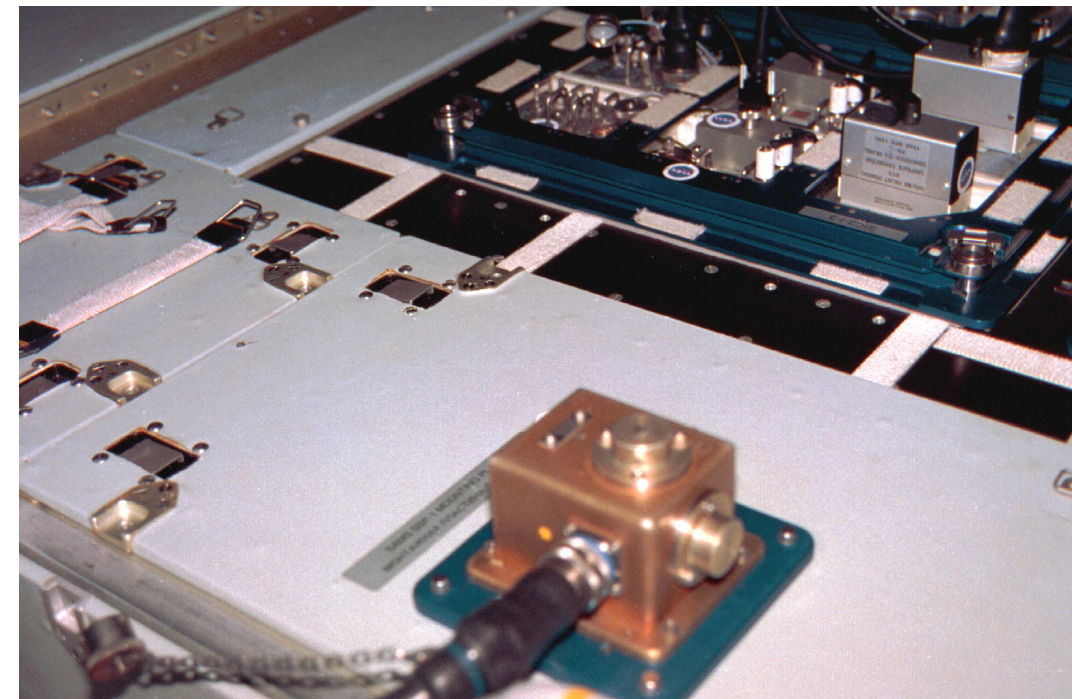

Figure MG-378 Accelerometer Head Near the BTS BCM in Priroda

NM22-23-21



**HARDWARE INTERFACE WITH SYSTEMS**

See Figure MG-380 for hardware interface diagram.

**SAMS DISPLAYS AND CONTROLS**

- See Figure MG-379 for Front Panel Displays.
- Table MG.21 identifies the procedural nomenclature.

The following sections define the switches and controls needed for operation, adjustments, and monitoring of SAMS.

**SWITCHES:**

**Power -** When in ON position (stationary), power is applied to SAMS. When momentarily set to RESET, the SAMS CPU is reset.

**Data Record -** When in ON position (stationary), data recording is enabled. Data recording is disabled in the OFF position (stationary).

**Disk Change -** When momentarily pushed up or down, SAMS is informed that a disk operation has been performed, and SAMS checks that the new disk is formatted and aligned properly.

**LIGHTS:**

**Power -** Green light turns on when power has been applied to SAMS via the power switch.

**Data -** Green light turns on when data recording is enabled.

**Drive 1 Full -** Yellow light turns on when disk side (facing up) in drive 1 is full. The light blinks when disk side (facing up) in drive 1 is bad or disk drive 1 is malfunctioning.

**Drive 2 Full -** Yellow light turns on when disk side (facing up) in drive 2 is full. The light blinks when disk side (facing up) in drive 2 is bad or disk drive 2 is malfunctioning.

**System Error -** Red light turns on when data is being lost or has been lost (not recorded). The light blinks when there is less than 30 minutes of recording space left between both disk drives.

**CONNECTORS:**

**GSE Test -** J15 is used for serial communications between SAMS and an external computer including MIPS-1.

**OPTICAL DISK DRIVES DISPLAYS AND CONTROLS**

**TRICOLOR LED:**

- Off — Power is not applied to disk drive.
- Green — Power is applied to disk drive.
- Yellow — Optical disk in drive is spinning.
- Red — Drive is reading from or writing to optical disk.

NOTE: Nominally, the Tricolor LED will alternate between yellow and red.

**DISK EJECTION LEVER:**

Lever — Lever is used to lock/unlock optical disk in drive, eject optical disk from drive, or abort recording when one disk drive is malfunctioning. \*

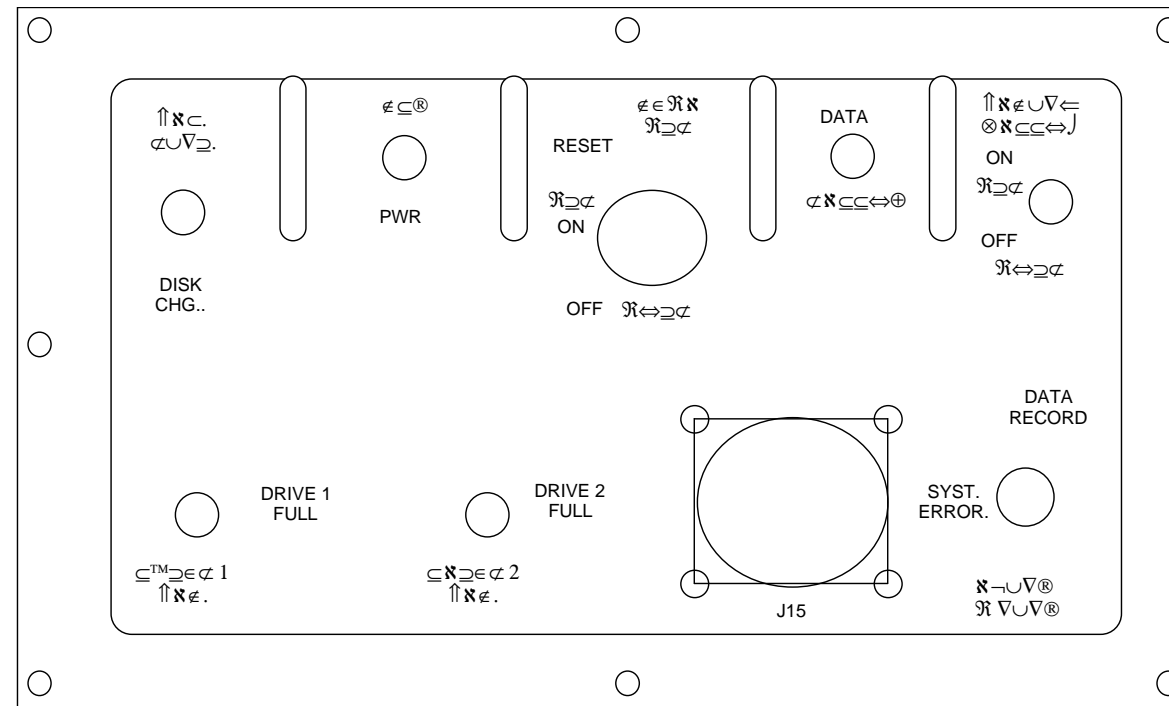

Figure MG-379 SAMS Front Panel Display

TABLE MG.21  
SAMS CONTROL PANEL

CONTROLS	
Disk Change	Momentary switch
Power	3 Position switch: OFF (down) ON (center) SET (up momentary)
Data Record	2 Position switch: OFF (down) ON (center)
GSE Test Port	Connector (MIPS interface)

DISPLAYS	
Power Lt	On, off
Data Lt	On, off
Drive 1 Full Lt	On, off
Drive 2 Full Lt	On, off
System Error Lt	On, off

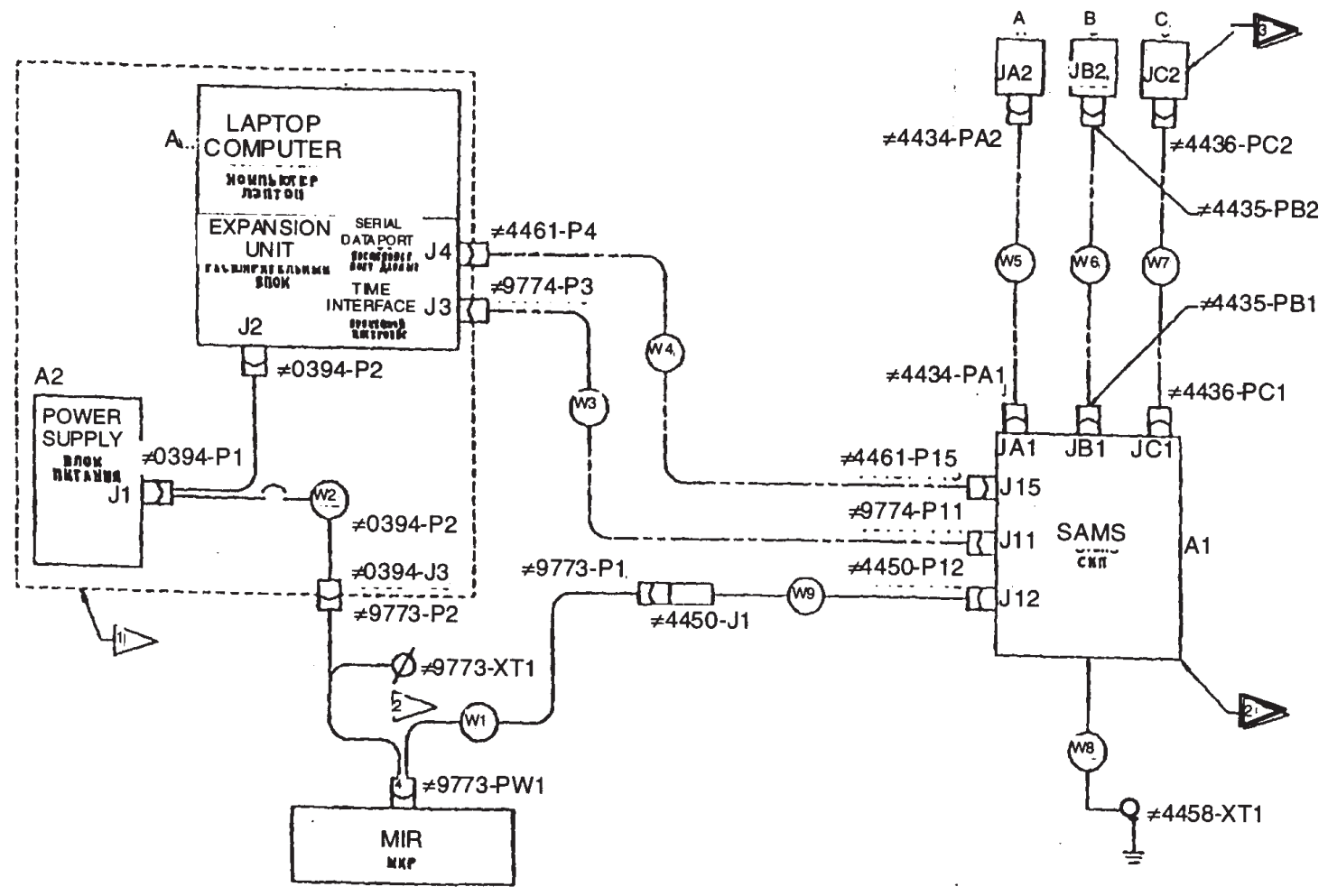

Figure MG-380 SAMS Hardware Interface Diagram

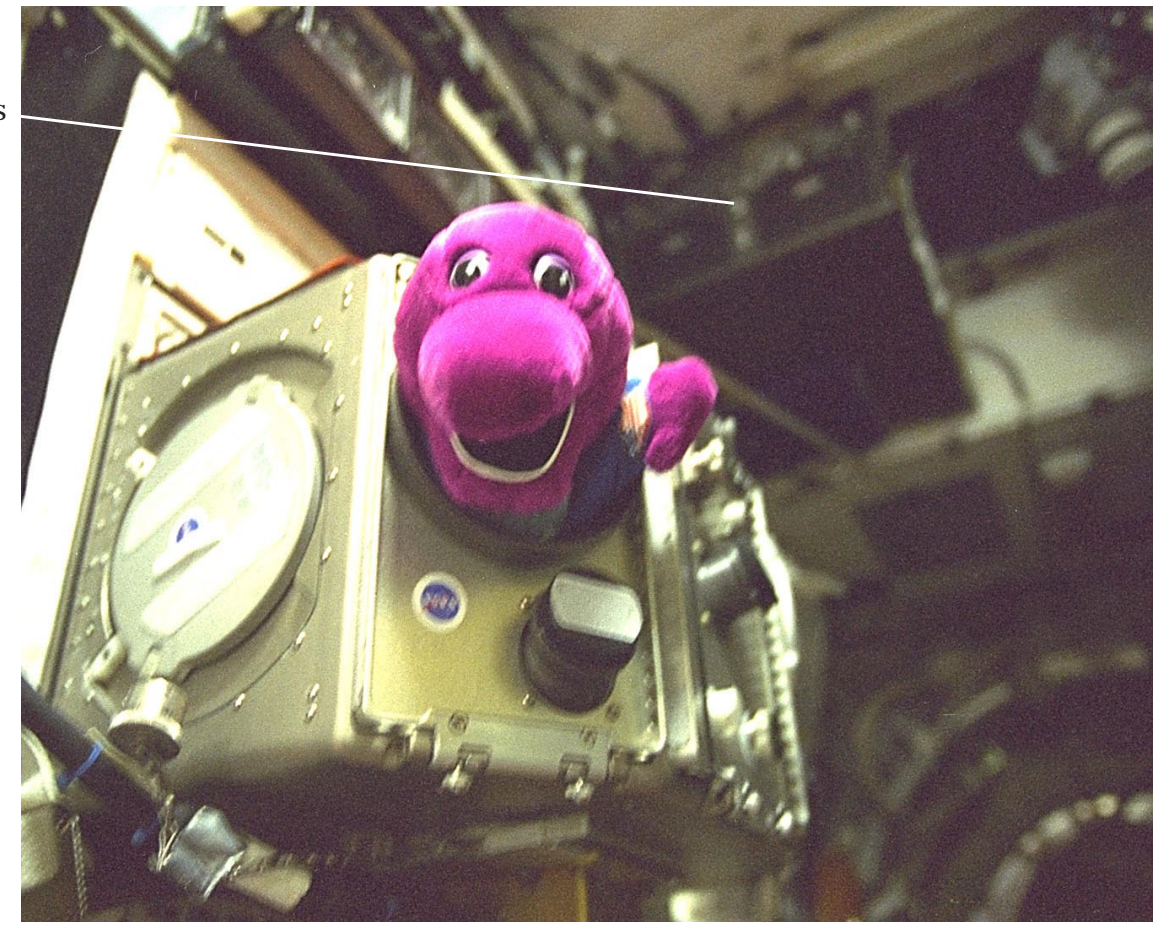

Figure MG-381 SAMS located Above the MGBX in Priroda STS-86-404-33

# TECHNICAL EVALUATION OF MIM #2 (TEM2)

## EXPERIMENT DESCRIPTION

The TEM vessels are related to the exploitation of reduced gravity for the observation of very sensitive free-surface phenomena. The containers are intended to test the capabilities of the MIM and examine free-surface oscillations.

The TEM Experiment consists of the TEM Test Vessel Assembly, the TEM Baseplate Assembly, and a TEM Power cable and is designed to be used on the Microgravity Vibration Isolation Mount (MIM). The TEM test vessel is mounted to the TEM baseplate after the baseplate is mounted to the flotor of the MIM, and uses the MGBX video recorder for the recording of science data. TEM will provide its own video camera, and MIM will provide a video extension cable to interface with the MGBX video recorder. One type of test vessel will be used in the performance of the TEM investigation. The test vessel employs manually operated knobs for the performance of the experiment.

## OBJECTIVES

- To characterize the vibration isolation capabilities of the MIM in a low-gravity environment.
- To characterize the ability of the MIM to induce controlled oscillations on a low-gravity, fluid physics experiment.
- To gather new information on free-surface oscillation and the damping of these oscillations.

## HARDWARE DESCRIPTION

The TEM is composed of the following major components: The TEM Test Vessel Assembly, the TEM Baseplate, TEM Power Cable, and TEM supplies (CD disks, floppy disks, and 8-mm video tapes).

## TEM TEST VESSEL ASSEMBLY

The TEM experiment Test Vessel is a self-contained unit which is secured to the TEM slide mount. The TEM Test Vessel consists of a reservoir (filled with fluid on the ground) and the experiment cavity proper. The reservoir and experiment cavity as well as the TEM Vessel top and bottom sides are constructed of Lexan. An aluminum piston and a stainless steel drive screw are used to manually transfer the experiment fluid from the reservoir into the experiment cavity of the vessel after opening a transfer valve. The transfer valve controls the flow of fluid from the reservoir into the experiment cavity volume.

The fluid will remain cohesive in the experiment cavity with the liquid-vapor interface filling approximately half of the cavity. All TEM Vessel junctions are sealed via BUNA-N O-rings to provide one level of containment. A second level of containment is offered by an aluminum housing with two Lexan sides for viewing. The housing is also sealed with a BUNA-N O-ring. The TEM Test Vessel also contains a hard-mounted camera for viewing the surface oscillation in the fluid within the experiment cavity. A polished aluminum mirror reflects the image of the cavity into the hard-mounted camera.

## TEM Controls

The TEM vessel has two control knobs. The TEM transfer valve knob is located on the side of the vessel and prevents the fluid from entering the cylindrical experiment cavity until it is opened. This valve is opened manually by a crewmember by pulling the valve knob. This process opens the valve and allows fluid from the reservoir to enter the experiment cavity volume. The piston that is used to transfer the test fluid from the reservoir to the experiment cavity volume is controlled via a reservoir knob located on the side of the TEM test vessel. The piston is displaced by manually turning the reservoir knob in the clockwise direction. The knob should be turned until movement stops.

## TEM Baseplate Assembly

The TEM Baseplate Assembly provides attachment points for the TEM translation stage,



Figure MG-382 TEM-2 Mounted on the MIM

S95-11613

**Principal Investigator:**  
Jeff Allen  
University of Dayton,  
Ohio  
Research Associate  
(216)433-3087

the TEM electronics box, and some electrical cables that are permanently affixed to the baseplate. The Baseplate Assembly is mounted on the MIM flotor and electrical connections are made by a separate TEM power Cable. One thermocouple is mounted on the translation stage of the Baseplate Assembly. The Thermocouple data will be recorded with the help of the mirror on video.

**HARDWARE OPERATIONS**

The TEM operations consist of unstowing the TEM hardware and configuring the hardware on the MIM flotor. The TEM Baseplate Assembly is first attached to the MIM flotor with three captive

screws. Next, one of the Test Vessels is affixed to the TEM Baseplate and clamped in place. There are two TEM Test Vessels each with two test runs. Each vessel will have one run with the MIM in the locked down position (MIM flotor clamps locked). The other run will consist of a set of 139 test points that will utilize both the active and passive MIM modes.

The batch files loaded on the MIM hard drive will contain all the data needed for the MIM to include the required frequencies and amplitudes. There will be four separate batch files, one for each run, on the MIM hard drive and on the TEM floppy disk as backup.

Power is supplied to the TEM from the MIM. The MIM video cable is then connected to the MGBX DAVID and to the TEM camera located on the TEM Vessel. The TEM experiment is then performed with video data of the fluid behavior in the TEM Vessel recorded on the MGBX Video System and Acceleration data recorded on the MIM Data System. The acceleration data is transferred from the MIM Data system to optical disks via the Magneto-Optical Drive (MOD). During the experiment, the crew should verify the functioning of the experiment by checking the video output on the MGBX DAVID. \*

Technological Evaluation of MIM (TEM) Test Vessel (Mounted to Baseplate)

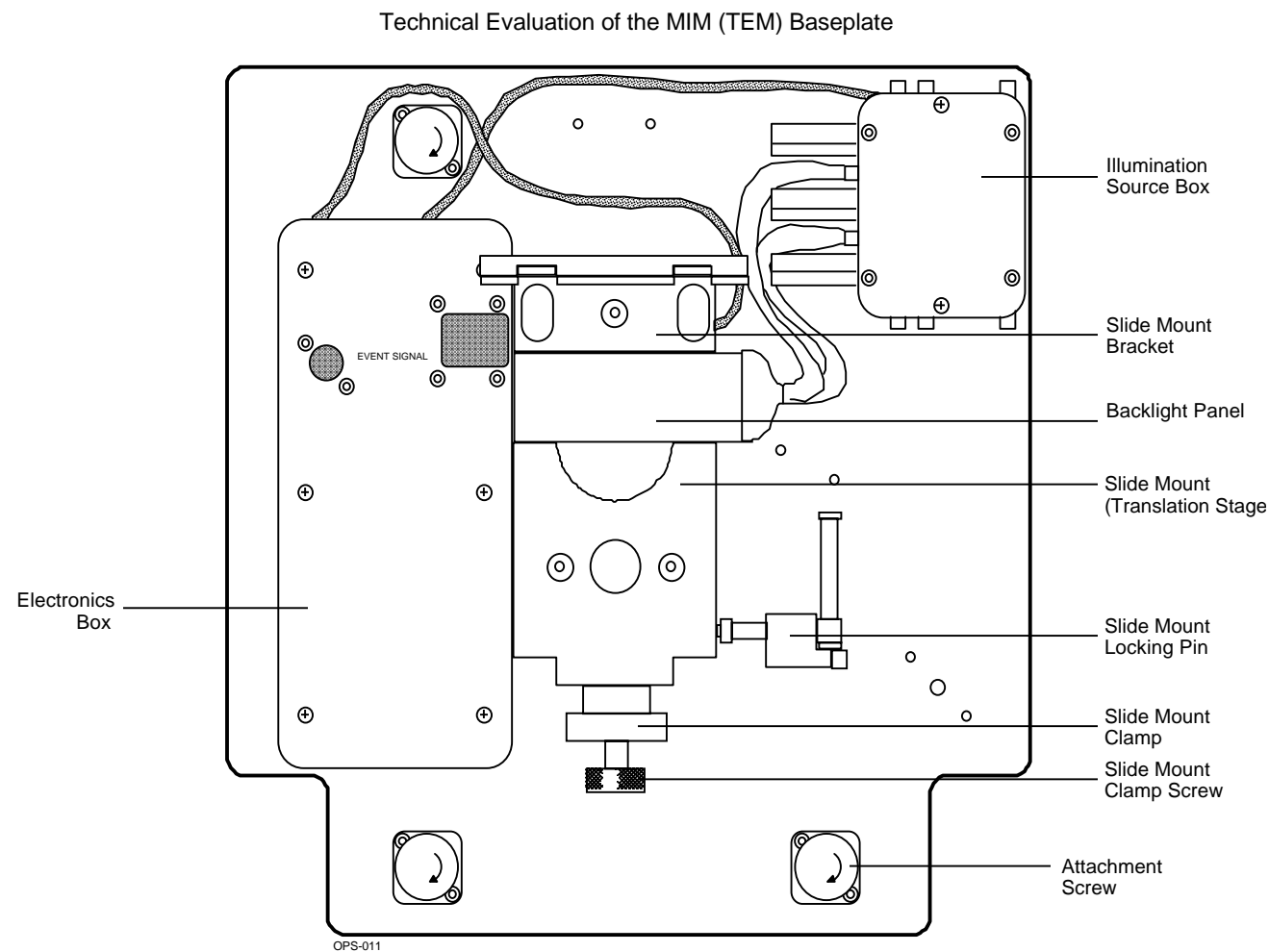

Figure MG-383 Drawing of MIM (TEM) Baseplate

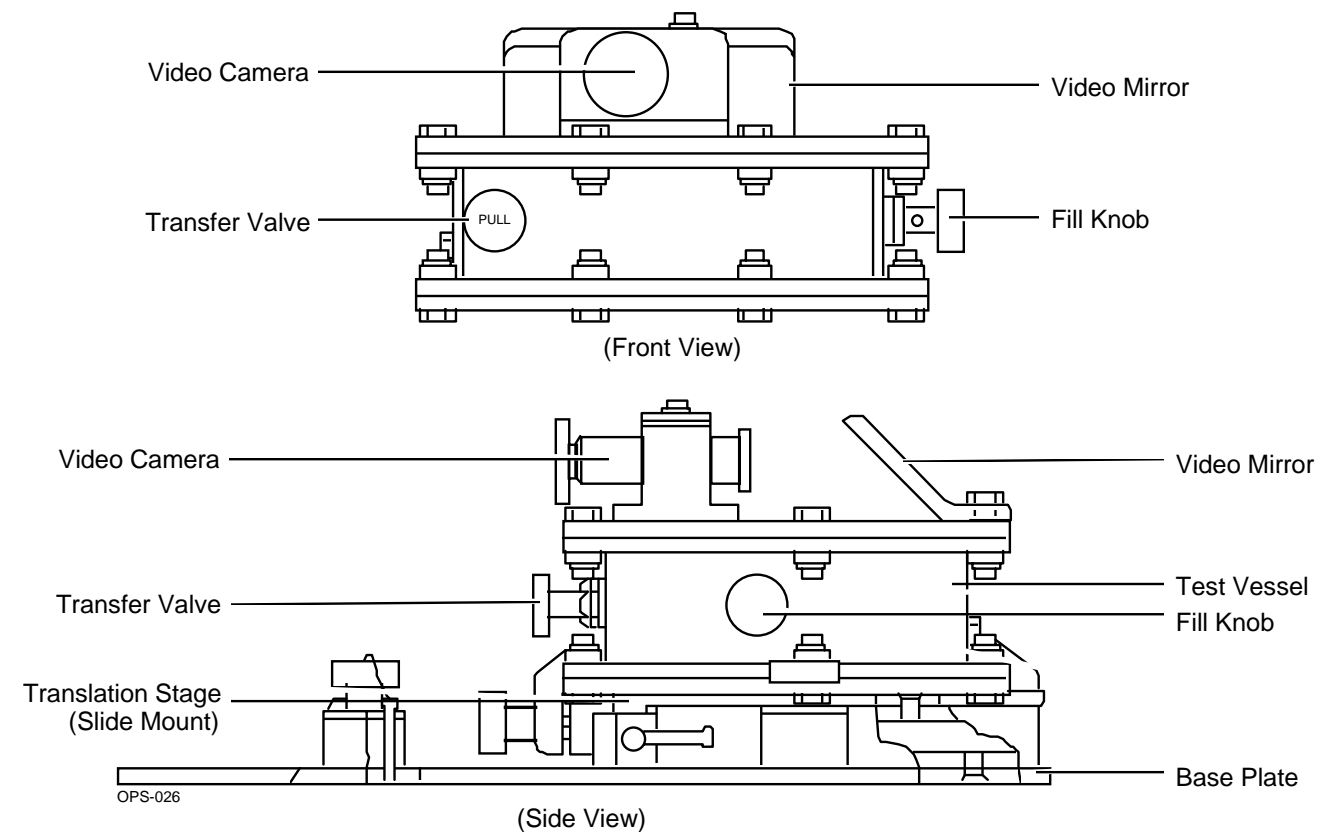

Figure MG-384 Side Drawing of TEM

**TEM ELECTRIC CABLE**

P/N: 60016M12A600  
 Qty: 1  
 Mass: .45 kg  
 Power: N/A  
 x,y,z: 13.97 x 3.18 x 21.29 cm

**TEM2 TEST VESSELS**

P/N: 60031MAFH000-FL-3, FL-4  
 Qty: 2  
 Mass: 2.25 kg  
 Power: N/A  
 x,y,z: 20.32 x 17.78 x 8.26 cm

**TEM 1 BASEPLATE ASSEMBLY**

P/N: 60016M12A200-FL  
 Qty: 1  
 Mass: 4.50 kg  
 Power: N/A  
 x,y,z: 30.83 x 36.20 x 5.31 cm